

ANIMAL SERVICES CATTERY ADDITION

INVITATION TO BID (ITB)

Bid No. NC19-026

**Nassau County
Board of County Commissioners
Nassau County, Florida**



**PROJECT MANUAL
CONTAINING
BIDDING REQUIREMENTS
CONTRACTOR'S PROPOSAL AGREEMENT
GENERAL CONDITIONS
SUPPLEMENTARY CONDITIONS AND SPECIFICATIONS
November 2019**

Prepared By: Nassau County Contract Management/Purchasing

Plans Prepared by:
Gillette & Associates, Inc.
20 S. 4 Street
Fernandina Beach, FL 32034

**PROJECT MANUAL
CONTAINING
BIDDING REQUIREMENTS
CONTRACTOR'S PROPOSAL
AGREEMENT
GENERAL CONDITIONS
SUPPLEMENTARY CONDITIONS
AND SPECIFICATIONS**

FOR

**Animal Services Cattery Addition
Bid Number NC19-026**

Prepared for:

**BOARD OF COUNTY COMMISSIONERS
Nassau County, Florida**

**Bid Documents
November 2019**

ANIMAL SERVICES CATTERY ADDITION**TABLE OF CONTENTS****DIVISION 00 - PROCUREMENT AND CONTRACTING REQUIREMENTS**

Section 00 11 10 - Advertisement for Bids

Section 00 21 15 - Instructions to Bidders

Section 00 41 15 - Bid Form

Section 00 43 15 - Bid Bond

Section 00 43 35 - Tabulation of Subcontractors & Suppliers

Section 00 44 55 - Florida Trench Safety Act Certification

Section 00 45 13 - Statement of Bidder's Qualifications

Section 00 45 19 - Non-collusion Affidavit

Section 00 45 20 - Drug-Free Workplace Certificate

Section 00 45 30 - Sworn Statement under Section 287.133(3)(a), Florida Statutes, on Public Entity Crimes

Section 00 45 35 - Bidder's Statement of Disputes, Litigation, Arbitration, and Surety Completion, Last Three (3) Years

Section 00 51 00 - Notice of Award

Section 00 52 15 - Sample Agreement

Section 00 55 00 - Notice to Proceed

Section 00 61 15 - Performance Bond

Section 00 61 16 - Payment Bond

Section 00 62 76 - Application and Certificate for Progress Payment

Section 00 63 15 - Contractor's Request for Information

Section 00 63 36 - Field Order

Section 00 63 49 - Work Change Directive

Section 00 63 63 - Change Order Request Form

Section 00 65 16 - Certificate of Substantial Completion

Section 00 65 19 - Certificate of Final Completion

Section 00 65 20 - Waiver and Release of Lien upon Progress Payment

Section 00 65 21 - Waiver and Release of Lien upon Final Payment

Section 00 72 15 - General Conditions

Section 00 73 15 - Supplementary Conditions

DIVISION 01 - GENERAL REQUIREMENTS

Section 01 11 00 - Summary of Work

Section 01 22 50 - Measurement and Payment

Section 01 31 19 - Project Meetings

Section 01 33 00 - Submittal Procedures

Section 01 41 23 - Permits and Fees

Section 01 45 00 - Quality Control

Section 01 50 00 - Temporary Facilities and Controls

Section 01 55 26 - Traffic Control

Section 01 60 00 - Product Requirements

Section 01 71 23 - Field Engineering

Section 01 77 00 - Closeout Procedures

DIVISION 31 – EARTHWORK

Section 31 05 10 – Site Preparation

Section 31 20 00 – Earthwork

Section 31 22 00 – Site Grading

Section 31 23 31 – Excavation for Structures and Pipe

Section 31 23 33 – Trenching and Backfilling

Section 31 25 00 – Erosion and Sedimentation Control

APPENDIX A

Nassau County As-Builts Requirement Check List

APPENDIX B

Plans and Drawings

APPENDIX C

Cage Specifications

EXHIBIT 1

General Information and Minimum Insurance Requirements

DIVISION 00

PROCUREMENT & CONTRACTING REQUIREMENTS

SECTION 00 11 10**ADVERTISEMENT FOR BIDS**

PROJECT: Animal Services Cattery Addition
Bid Number NC19-026
Nassau County, Florida

COUNTY: Board of County Commissioners
Nassau County, Florida
96135 Nassau Place, Suite 1
Yulee, Florida 32097

ENGINEER OF: Gillette & Associates, Inc.
RECORD 20 S. 4th Street
Fernandina Beach, FL 32034

PROJECT Jeff Little
MANGER: Nassau County Facilities Maintenance
45195 Musselwhite Road
Callahan, FL 32011

MANDATORY PRE-BID CONFERENCE: MONDAY, NOVEMBER 25, 2019 AT 11:00 AM

LOCATION OF MANDATORY PRE-BID CONFERENCE:

James S. Page Governmental Complex
Office of Management and Budget Conference Room
96135 Nassau Place, Suite 1
Yulee, Florida 32097

BID DEADLINE: WEDNESDAY, DECEMBER 11, 2019 AT 4:00 P.M.

BID OPENING: THURSDAY, DECEMBER 12, 2019 AT 10:00 A.M., OR SOON THERE AFTER

Robert M. Foster Justice Center
Office of Ex-Officio Clerk, Second Floor
76347 Veterans Way
Yulee, Florida 32097

1.0 WORK DESCRIPTION

This project consists of labor, materials and supervision for the construction and addition of a Cattery Building and installation of cages at Nassau County Animal Services. The work to be performed is generally described as the construction of a new Cattery Building and includes, but is not limited to the following:

- Demolition Services and relocation of elements within the footprint of the proposed construction
- All Utility Connections (water, sewer, electrical, mechanical, including potable and DWV piping)
- Roofing
- Painting and Waterproofing
- Concrete/Foundations
- Wood Framing
- Masonry
- Plumbing
- HVAC
- Purchase and Installation of Cages

All work shall be in accordance with the construction drawings, specifications, and contract documents.

2.0 RECEIPT OF BIDS

ALL BIDDERS must be qualified for the type of work for which the BID is submitted. **Bidders should note that all bids must be delivered to the clerk's office. Bidders must allow ample time to pass through the County security system when entering the building.** BIDS must be enclosed in an opaque envelope and marked:

Animal Services Cattery Addition

BID NUMBER: NC19-026

BIDS SHALL BE ADDRESSED TO:

Board of County Commissioners, Nassau County
Office of the Ex-Officio Clerk
76347 Veterans Way, Suite 456
Yulee, Florida 32097

3.0 CONTRACT DOCUMENTS

The CONTRACT DOCUMENTS, consisting of ADVERTISEMENT FOR BIDS, INFORMATION FOR BIDDERS, BID, BID BOND, AGREEMENT, GENERAL CONDITIONS, SUPPLEMENTAL GENERAL CONDITIONS (IF APPLICABLE), PAYMENT BOND, PERFORMANCE BOND, NOTICE OF AWARD, NOTICE TO PROCEED, CHANGE ORDER, DRAWINGS, SPECIFICATIONS, SPECIAL CONDITIONS and ADDENDA, may be examined at the following location:

Contract Management
96135 Nassau Place Suite 2
Yulee, Florida 32097

There are two ways to download the ITB documents. The documents are available on Onvia Demandstar at <http://www.demandstar.com> or you can download them from the County's Box.com site below:

<https://app.box.com/s/16ibtginufakakt9u470q25nqfttsexp>

4.0 BONDS (BID, PERFORMANCE AND PAYMENT)

BIDS must be accompanied by a Certified Check or BID BOND of a reputable bonding company authorized to do business in the State of Florida in the amount of five percent (5%) of the total amount of the BID to guarantee that the Contractor will enter into a Contract in the form prescribed and will provide the required bond.

The successful BIDDER(s) must provide an acceptable contract PERFORMANCE BOND in the amount of one hundred percent (100%) of the Contract Price, and a PAYMENT BOND in the amount of one hundred percent (100%) of the Contract Price.

5.0 BID WITHDRAWAL

No BIDS may be withdrawn for a period of ninety (90) days after closing time scheduled for receipt of BIDS.

6.0 RIGHT TO REJECT

The County reserves the right to reject any and all BIDS and waive all informalities in whole or in part, with or without cause, and/or to accept the bid that, in its best judgment, will be for the best interest of Nassau County, Florida.

7.0 PUBLIC ENTITY CRIME

A person or affiliate who has been placed on the convicted vendor list following a conviction for a public entity crime may not submit a proposal/bid on a contract to provide any goods or services to a public entity, may not submit a proposal/bid on a contract with a public entity for the construction or repair of a public building or public work, may not submit a proposal/bid on leases or real property to a public entity, may not be awarded or perform work as a contractor, supplier, subcontractor or consultant under contract with any public entity, and may not transact business with any public entity in excess of the threshold amount provided in Section 287.017, Florida Statutes, for Category Two for a period of thirty six months from the date of being placed on the convicted vendor list.

8.0 INFORMATION CONTACT

For further information or clarification, contact Grayson Hagins, Contract/Purchasing Manager at (904) 530-6040. ghagins@nassaucountyfl.com

9.0 DISABILITIES REQUIRING ACCOMMODATION

Persons with disabilities requiring accommodation in order to participate in this program or activity should contact the Office of the Ex-Officio Clerk to the Board of County Commissioners at (904) 548-4660 or Florida Relay Service at 1-800-955-8770 (v) or 1-800-955-8771 (TDD) at least seventy two hours in advance to request such accommodation.

10.0 PUBLIC MEETINGS AND PUBLIC RECORDS LAWS FOR GOVERNMENT CONTRACTING**Effective July 1, 2012**

Pursuant to recent changes in Florida Statutes Chapter 119.071 (General Exemptions from inspection or copying of public records) the bid opening process is temporarily exempt from Public Records requirements, except bids received pursuant to a competitive solicitation for construction or repairs on a public building or public work. Information may be released to the public once the Board provides a notice of intended decision or 30 days after the bid opening, whichever is earlier.

Pursuant to recent changes in Florida Statutes Chapter 286.0113 (General exemptions from public meeting requirements) any portion of a meeting in which negotiations with a vendor is conducted as part of the "competitive negotiation" process at which a vendor makes an oral presentation or answers questions as part of the "competitive solicitation" process are exempt from public meeting requirements until the Board provides notice of an intended decision or until 30 days after bid opening, whichever is earlier. Any portion of a committee meeting at which negotiation strategies are discussed is exempt.

A complete record shall be made of any portion of an exempt meeting; no portion may be held off the record. The recording of and any records presented at the exempt meeting are exempt from FS119.071

until such time as the board provides notice of an intended decision or 30 days after opening the bids, proposals or final replies.

Please refer to Florida Statutes Chapter 119.071, Chapter 255.0518 and Chapter 286.0113 for further details.

NASSAU COUNTY BOARD OF COUNTY COMMISSIONERS

Justin M. Taylor, Chair

ATTEST:

John A. Crawford
Its: Ex-Officio Clerk

An Affirmative Action/Equal Opportunity Employer

SECTION 00 21 15**INSTRUCTIONS TO BIDDERS****ARTICLE 1 DEFINED TERMS**

- 1 .01** Terms used in these Instructions to Bidders will have the meanings indicated in the General Conditions and Supplementary Conditions. Additional terms used in these Instructions to Bidders have the meanings indicated below which are applicable to both the singular and plural thereof:
- A. Bidder - The individual or entity who submits a Bid directly to the County.
 - B. Issuing Office - The office from which the Bidding Documents are to be issued and where the bidding procedures are to be administered.
 - C. Successful Bidder - The lowest responsible Bidder submitting a responsive Bid to whom County (on basis of County's evaluation as herein provided) makes an award.

ARTICLE 2 COPIES OF BIDDING DOCUMENTS

- 2.01** Complete sets of Bidding Documents in the number and for the payment sum, if any, stated in the Advertisement or Invitation to Bid may be obtained from the Issuing Office.
- 2.02** Complete sets of Bidding Documents must be used in preparing Bids; neither the County nor Engineer of Record assumes any responsibility for errors or misinterpretations resulting from the use of incomplete sets of Bidding Documents.
- 2.03** The County and Engineer of Record in making copies of Bidding Documents available on the above terms do so only for the purpose of obtaining Bids for the Work and do not confer a license or grant for any other use.

ARTICLE 3 QUALIFICATIONS OF BIDDERS

- 3.01** The County may make such investigations as necessary to determine the ability of the Bidder to perform the Work, and the Bidder shall furnish to the County all such information and data for this purpose as the County may request. The County reserves the right to reject any bid if the evidence submitted by, or investigation of, such Bidder fails to satisfy the County that such Bidder is properly qualified to carry out the obligations of the contract and to complete the work contemplated therein. Conditional bids will not be accepted.

- 3.02** To demonstrate Bidder's qualifications to perform the Work, Bidder shall submit written evidence such as financial data, previous experience, present commitments, and such other data as may be called for in Bidder's Qualification Statement.

ARTICLE 4 EXAMINATION OF BIDDING DOCUMENTS, OTHER RELATED DATA, AND SITE

4.01 Subsurface and Physical Conditions

- A. The Supplementary Conditions identify:
1. Those reports or explorations and tests of subsurface conditions at or contiguous to the Site that Engineer of Record has used in preparing the Bidding Documents.
 2. Those drawings of physical conditions in or relating to existing surface and subsurface structures at or contiguous to the Site (except Underground Facilities) that Engineer of Record has used in preparing the Bidding Documents.
- B. Copies of the reports and drawings referenced in paragraph 4.01.A will be made available by the County to any Bidder on request. Those reports and drawings are not part of the Contract Documents, but the "technical data" contained therein upon which Bidder is entitled to rely as provided in paragraph 4.02 of the General Conditions has been identified and established in paragraph 4.02 of the Supplementary Conditions. Bidder is responsible for any interpretation or conclusion Bidder draws from any "technical data" or any other data, interpretations, opinions, or information contained in such reports or shown or indicated in such drawings.

4.02 Underground Facilities

Information and data shown or indicated in the Bidding Documents with respect to existing Underground Facilities at or contiguous to the Site is based upon information and data furnished to the County and Engineer of Record by the Utility Owner of such Underground Facilities, including the County, or others.

4.03 Hazardous Environmental Conditions

- A. The Supplementary Conditions identify those reports and drawings relating to a Hazardous Environmental Condition identified at the Site, if any, that Engineer of Record has used in preparing the Bidding Documents.

- B. Copies of reports and drawings referenced in paragraph 4.03.A will be made available by the County to any Bidder on request. Those reports and drawings are not part of the Contract Documents, but the "technical data" contained therein upon which Bidder is entitled to rely as provided in paragraph 4.06 of the General Conditions has been identified and established in paragraph 4.06 of the Supplementary Conditions. Bidder is responsible for any interpretation or conclusion Bidder draws from any "technical data" or any other data, interpretations, opinions, or information contained in such reports or shown or indicated in such drawings.
- 4.04** Provisions concerning responsibilities for the adequacy of data furnished to prospective Bidders with respect to subsurface conditions other physical conditions and Underground Facilities, and possible changes to Bidding Documents due to offering or unanticipated conditions appear in paragraphs 4.02, 4.03, and 4.04 of the General Conditions. Provisions concerning responsibilities for the adequacy of data furnished to prospective Bidders with respect to a Hazardous Environmental Condition at the Site, if any, and possible changes in the Contract Documents due to any Hazardous Environmental Condition uncovered or revealed at the Site which was not shown or indicated in the Drawings and Specifications or identified in the Contract Documents to be within the scope of Work appear in paragraph 4.06 of the General Conditions.
- 4.05** On request, the County will provide Bidder access to the Site to conduct such examinations, investigations, explorations, tests, and studies Bidder deems necessary for submission of a Bid. Bidder shall fill all holes and clean up and restore the Site to its former condition upon completion of such explorations, investigations, tests, and studies.
- 4.06** Reference is made to Article 7 of the General Conditions for the identification of the general nature of other work that is to be performed at the Site by the County or others (such as utilities and other prime contractors) that relates to the Work for which a Bid is to be submitted. On request, the County will provide to each Bidder for examination access to or copies of Contract Documents (other than portions thereof related to price) for such other work.
- 4.07** It is the responsibility of each Bidder before submitting a Bid to:
- A. Examine and carefully study the Bidding Documents, including any Addenda and other related data identified in the Bidding Documents;
- B. Visit the site to become familiar with and satisfy Bidder as to the general, local and Site conditions that may affect cost, progress, and performance of the Work;

- C. Become familiar with and satisfy Bidder as to all federal, state, and local Laws and Regulations that may affect cost, progress, or performance of the Work;
- D. Carefully study all reports of explorations and tests or subsurface conditions at or contiguous to the Site and all drawings of physical conditions in or relating to existing surface or subsurface structures at or contiguous to the Site (except Underground Facilities) which have been identified in the Supplementary Conditions as provided in paragraph 4.02 of the General Conditions, and carefully study all reports and drawings or a Hazardous Environmental Condition, if any, at the Site which have been identified in the Supplementary Conditions as provided in paragraph 4.06 of the General Conditions;
- E. Obtain and carefully study (or assume responsibility for doing so) all additional or supplementary examinations, investigations, explorations, tests, studies, and data concerning conditions (surface, subsurface, and Underground Facilities) at or contiguous to the Site which may affect cost, progress, or performance of the Work or which relate to any aspect of the means, methods, techniques, sequences, and procedures of construction to be employed by Bidder, including any specific means, methods, techniques, sequences, and procedures of construction expressly required by the Bidding Documents, and safety precautions and programs incident thereto;
- F. Agree at the time of submitting its Bid that no further examinations, investigations, explorations, tests, studies, or data are necessary for the determination of its Bid for performance of the Work at the price bid and within the times and in accordance with the other terms and conditions of the Bidding Documents;
- G. Become aware of the general nature of the work to be performed by the County and others at the Site that relates to the Work as indicated in the Bidding Documents;
- H. Correlate the information known to Bidder, information and observations obtained from visit to Site, reports and drawings identified in the Bidding Documents, and all additional examinations, investigations, explorations, tests, studies, and data with the Bidding Documents;
- I. Promptly give the County written notice of all conflicts, errors, ambiguities, or discrepancies that Bidder discovers in the Bidding Documents and confirm that the written resolution thereof by the County is acceptable to Bidder and;

- J. Determine that the Bidding Documents are generally sufficient to indicate and convey understanding of all terms and conditions for the performance of Work.
- 4.08** Each bidder must inform himself fully of the conditions relating to the construction of the project and the employment of labor thereon. Failure to do so will not relieve a successful bidder of his obligation to furnish all material and labor necessary to carry out the provisions of this contract. Insofar as possible the contractor, in carrying out the work, must employ such methods or means as will not cause any interruption of or interference with the work of any other contractor.
- 4.09** The submission of a Bid will constitute an incontrovertible representation by Bidder that Bidder has complied with every requirement of this Article 4, that without exception the Bid is premised upon performing and furnishing the Work required by the Bidding Documents and applying any specific means, methods, techniques, sequences and procedures of construction that may be shown or indicated or expressly required by the Bidding Documents, that Bidder had given the County written notice of all conflicts, errors, ambiguities and discrepancies that Bidder has discovered in the Bidding Documents and written resolutions thereof by the County are acceptable to Bidder, and that the Bidding Documents are generally sufficient to indicate and convey understanding of all terms and conditions for performing and furnishing the Work.

ARTICLE 5 PRE-BID CONFERENCE

- 5.01** A mandatory pre-bid conference will be held for this project. See the Advertisement for Bids for details of date, time and location. If needed, a visit to the project site will be immediately following the pre-bid conference. All potential Bidders are REQUIRED to attend. Only those in attendance can submit a bid.

ARTICLE 6 SITE AND OTHER AREAS

- 6.01** The Site is identified in the Bidding Documents. All additional lands and access thereto required for temporary construction facilities, construction equipment, or storage of materials and equipment to be incorporated in the Work are to be obtained and paid for by Contractor. Easements for permanent structures or permanent changes in existing facilities are to be obtained and paid for by the County unless otherwise provided in the Bidding Documents.

ARTICLE 7 INTERPRETATIONS AND ADDENDA

- 7.01** No interpretation of the meaning of the plans, specification or other pre-bid documents will be made to any bidder orally. Every request for such interpretation shall be in writing, addressed to Contract Management and, to be given consideration, must be

received at least seven calendar days prior to the date fixed for the opening of bids. Requests for additional information or clarifications will be received by letter, facsimile, or email. The request must contain the submitter's name, address, phone number, facsimile number, and email address and addressed to:

Grayson Hagins, Contract/Purchasing Manager
Nassau County Contract Management
96135 Nassau Place, Suite 2
Yulee, Florida 32097
(904) 530-6040
Email: ghagins@nassaucountyfl.com

- 7.02** Any and all such interpretations and any supplemental instructions will be in the form of written addenda not later than 72 hours prior to the date fixed for the opening of bids.
- 7.03** Addenda may be issued to clarify, correct, or change the Bidding Documents as deemed advisable by the County, Engineer of Record or Project Manager.
- 7.04** It is the Bidder's responsibility to ensure that all addenda were received. The bidder should verify with the designated contact person prior to submitting a bid that all addenda have been received. Bidders are required to acknowledge the number of addenda received on the Bid Form, section 3.01. A Failure of any bidder to receive any such addendum or interpretation shall not relieve such bidder from any obligation under the bid as submitted. All addenda so issued shall become part of the contract documents.

ARTICLE 8 BID SECURITY

- 8.01** A Bid must be accompanied by cash, certified check of the Bidder, or a bid bond prepared on the form of bid bond attached hereto, duly executed by the Bidder as principal and having as surety thereon a surety company approved by the County, in the amount of 5% of the Bid. Cash, checks and bid bonds will be returned to all except the three lowest bidders. After award by the Board, the remaining cash checks or bid bonds will be returned promptly after the County and the accepted bidder have executed the contract, or, if no award has been made within 30 days after the date of the opening of Bids, upon demand of the Bidder at any time thereafter, so long as notification of the acceptance of the Bid has not taken place.
- 8.02** Bid security of other Bidders whom the County believes do not have a reasonable chance of receiving the award will be returned within seven days after the Bid opening.

ARTICLE 9 CONTRACT TIMES

- 9.01** The number of days within which, or the dates by which, the Work is to be (a) Substantially Completed and (b) also completed and ready for final payment are set forth in the Bid Form.

ARTICLE 10 LIQUIDATED DAMAGES

- 10.01** The successful bidder, upon failure or refusal to execute and deliver the contract and bonds required within 10 days after receipt of notice of the acceptance of the bid, shall forfeit to the County, as liquidated damages for such failure or refusal, the security deposited with the bid.

ARTICLE 11 SUBSTITUTE AND "OR-EQUAL" ITEMS

- 11.01** The Contract, if awarded, will be on the basis of materials and equipment specified or described in the Bidding Documents without consideration of possible substitute "or-equal" items. Whenever it is specified or described in the Bidding Documents that a substitute or "or-equal" item of material or equipment may be furnished or used by if acceptable to Engineer of Record and Project Manager, application for such acceptance will not be considered by Engineer of Record and Project Manager until after the Effective Date of the Agreement. The procedure for submission of any such application by and consideration by Engineer of Record and Project Manager is set forth in the General Conditions and may be supplemented in the General Requirements.

ARTICLE 12 SUBCONTRACTORS, SUPPLIERS AND OTHERS

- 12.01** If the Supplementary Conditions require the identity of certain Subcontractors, Suppliers, individuals, or entities to be submitted to the County in advance of a specified date prior to the Effective Date of the Agreement, the apparent Successful Bidder, and any other Bidder so requested, shall within five days after Bid opening, submit to the County a list of all such Subcontractors, Suppliers, individuals, or entities proposed for those portions of the Work for which such identification is required. Such list shall be accompanied by an experience statement with pertinent information regarding similar projects and other evidence of qualification for each Subcontractor, Suppliers, individuals, or entity if requested by the County. If the County, Project Manager or Engineer of Record, after due investigation, has reasonable objection to any proposed Subcontractor, Supplier, individual or entity, the County may, before the Notice of Award is given request apparent Successful Bidder to submit a substitute, without an increase in the Bid.

- 12.02** If apparent Successful Bidder declines to make any such substitution, the County may award the Contract to the next lowest Bidder that proposes to use acceptable Subcontractors, Suppliers, individuals, or entities. Declining to make requested substitutions will not constitute grounds for forfeiture of the Bid security of any Bidder. Any Subcontractor, Supplier, individual, or entity so listed and against which the County, Project Manager or Engineer of Record makes no written objection prior to giving of the Notice of Award will be deemed acceptable to the County and Engineer of Record subject to revocation of such acceptance after Effective Date of the Agreement as provided in paragraph 6.06 of the General Conditions.
- 12.03** Bidder shall not be required to employ any Subcontractor, Supplier, individual, or entity against whom Contractor has reasonable objection.

ARTICLE 13 PREPARATION OF BID

- 13.01** The Bid Form is included in the Bidding Documents.
- 13.02** Each bid must be submitted in a sealed envelope bearing on the outside the name of the bidder, his/her address, and the name of the project for which the bid is submitted. If forwarded by mail, the sealed envelope containing the bid must be enclosed in another envelope addressed as specified in the bid form.
- 13.03** A Bid by a corporation shall be executed in the corporate name by the president or a vice-president or other corporate officer accompanied by evidence of authority to sign. The corporate seal shall be affixed and attested by the secretary or an assistant secretary. The corporate address and state of incorporation shall be shown on the form.
- 13.04** A Bid by a partnership shall be executed in the partnership name and signed by a partner (whose title must appear under the signature), accompanied by evidence of authority to sign. The official address of the partnership shall be shown below the signature.
- 13.05** A Bid by a limited liability company shall be executed in the name of the firm by a member and accompanied by evidence of authority to sign. The state of formation of the firm and the official address of the firm must be shown below the signature.
- 13.06** A Bid by an individual shall show the Bidder's name and official address.
- 13.07** A Bid by a joint venture shall be executed by each joint venture in the manner indicated on the Bid Form. The official address of the joint venture must be shown below the signature.

- 13.08** All names shall be typed or printed in ink below the signatures.
- 13.09** The Bid shall contain an acknowledgement of receipt of all Addenda, the numbers of which shall be filled in on the Bid Form.
- 13.10** The address and telephone number for communications regarding the Bid shall be shown
- 13.11** The Bid shall contain evidence of Bidder's authority and qualification to do business in the State of Florida. The Bidder shall also be a state-certified Contractor in good standing and hold current registration with the Florida Construction Industry Licensing Board of the State Department of Professional Regulation. The type of license must be in a class that is related to the general nature of the construction to be performed on this project. The Bidder's State Contractor's license number for the State of the project shall be shown on the Bid Form.

ARTICLE 14 BASIS OF BID; EVALUATION OF BIDS

14.01 Lump Sum Price

- A. Bidders shall submit a Bid on a lump sum and are to include, but is not limited to, all labor, materials, equipment, supervision and incidentals necessary to perform the work as indicated in the contract documents.
- B. The County reserves the right to evaluate the bids on any base bid-alternate/add on combination that is in the best interest of the County.
- 14.02** The Bid price shall include such amounts as the Bidder deems proper for overhead and profit on account of cash allowances, if any, named in the Contract Documents as provided in paragraph 11.02 of the General Conditions.

ARTICLE 15 SUBMITTAL OF BID

- 15.01** Each prospective Bidder is furnished one copy of the Bidding Documents.
- 15.02** A bid shall be submitted, **one original and three copies**, no later than the date and time prescribed and at the place indicated in the Advertisement or Invitation to Bid and shall be enclosed in an opaque sealed envelope plainly marked with the Project title (and, if applicable, the designated portion of the Project for which the Bid is submitted), the name and address of Bidder, and shall be accompanied by the Bid security and other required documents. If a Bid is sent by mail or other delivery system, the sealed

envelope containing the Bid shall be enclosed in a separate envelope plainly marked on the outside with the notation "BID ENCLOSED".

ARTICLE 16 MODIFICATION AND WITHDRAWAL OF BID

16.01 A Bid may be modified or withdrawn by an appropriate document duly executed in the manner that a Bid must be executed and delivered to the place where Bids are to be submitted prior to the date and time from the opening of Bids.

16.02 Any Bid may be withdrawn prior to the scheduled time for the opening of bids or authorized postponement thereof. Any Bid received after the time and date specified shall not be considered. No Bidder may withdraw a bid within 90 days after the actual date of the opening thereof.

ARTICLE 17 OPENING OF BIDS

17.01 Bids will be opened at the time and place indicated in the Advertisement or Invitation to Bid. An abstract of the amounts of the base Bids and major alternatives, if any, will be made available to Bidders pursuant to s. 119.071 and s. 255.0518 (effective July 1, 2012), Florida Statutes.

17.02 The County may consider informal any Bid not prepared and submitted in accordance with the provisions thereof and may waive any informalities or reject any and all Bids.

ARTICLE 18 BIDS TO REMAIN SUBJECT TO ACCEPTANCE

18.01 All Bids will remain subject to acceptance for the period of time stated in the Bid Form, but the County may, in its sole discretion, release any Bid and return the Bid security prior to the end of this period.

ARTICLE 19 AWARD OF CONTRACT

19.01 The County reserves the right to reject any and/or all Bids, including without limitation, nonconforming, nonresponsive, unbalanced or conditional Bids. The County further reserves the right to reject the Bid of any Bidder whom it finds, after reasonable inquiry and evaluation, to be non-responsible. The County may also reject the Bid of any Bidder if the County believes that it would not be in the best interest of the Project to make an award to that Bidder. The County also reserves the right to waive all informalities not involving price, time, or changes in the Work and to negotiate contract terms with the Successful Bidder.

- 19.02** More than one Bid for the same Work from an individual or entity under the same or different names will not be considered. Reasonable grounds for believing that any Bidder has an interest in more than one Bid for the Work may be cause for disqualification of that Bidder and the rejection of all Bids in which that Bidder has an interest.
- 19.03** In evaluating Bids, the County will consider whether or not the Bids comply with the prescribed requirements, and such alternates, unit prices and other data, as may be requested in the Bid Form or prior to the Notice of Award.
- 19.04** In evaluating Bidders, the County will consider the qualifications of Bidders and may consider the qualifications and experience of Subcontractors, Suppliers, and other individuals or entities proposed for those portions of the Work for which the identity of Subcontractors, Suppliers: and other individuals or entities must be submitted as provided in the Supplementary Conditions.
- 19.05** The County may conduct such investigations as it deems necessary to establish the responsibility, qualifications, and financial ability of Bidders, proposed Subcontractors, Suppliers, individuals, or entities to perform the Work in accordance with the Contract Documents.
- 19.06** If the contract is awarded, the County will award the Contract to Bidder whose Bid is in the best interests of the Project.

ARTICLE 20 CONTRACT SECURITY AND INSURANCE

- 20.01** Article 5 of the General Conditions, as may be modified by the Supplementary Conditions, sets forth the County's requirements as to performance and payment Bonds and insurance. When the Successful Bidder delivers the executed Agreement to the County, such Bonds must accompany it.
- 20.02** Provisions for indemnification by Contractor is set forth in the Agreement, at Paragraph 6.20 of the General Conditions, as amended by the Supplementary Conditions, and are incorporated here by reference.
- 20.03** Simultaneously, with delivery of the executed contract, the Contractor shall furnish a surety bond or bonds as security for faithful performance of this contract and for the payment of all persons performing labor on the project under this contract and furnishing materials in connection with this contract, as specified in the General Conditions included herein. The surety on such bond and bonds shall be a duly authorized surety company satisfactory to the County.

- 20.04** Attorneys-in-fact who sign bid bonds or contract bonds must file with each bond a certified and effectively dated copy of their power of attorney.

ARTICLE 21 SIGNING OF AGREEMENT

- 21.01** When the County gives Notice of Intent to Award to the Successful Bidder, it shall be accompanied by the Agreement. Successful Bidder shall sign and deliver the required number of counterparts of the Agreement and attached documents to the County prior to the date set for Board approval and execution. The County shall deliver one fully signed counterpart to Successful Bidder.
- 21.02** The County has the right to approve or reject the recommendation of award. The Agreement is not valid unless fully executed by the Contractor and the Nassau County Board of County Commissioners.

SECTION 00 41 15

BID FORM

PROJECT IDENTIFICATION: **Animal Services Cattery Addition**
 Bid Number NC19-026
 Nassau County, Florida

BID DEADLINE: **WEDNESDAY, DECEMBER 11, 2019 at 4:00 PM**

THIS BID IS SUBMITTED TO: **Board of County Commissioners, Nassau County**
 Judicial Annex
 Office of the Ex-Officio Clerk
 76347 Veterans Way, Suite 456
 Yulee, Florida 32097

1.01 The undersigned Bidder proposes and agrees, if this Bid is accepted, to enter into an agreement with the County in the form included in the Bidding Documents to perform all Work as specified or indicated in the Bidding Documents for the prices and within the times indicated in this Bid and in accordance with the other terms and conditions of the Bidding Documents.

Company Name (typed or printed): _____

Business address: _____

Phone No.: _____ Fax No.: _____

Contact Name: _____

Contact Title: _____

Contact email address: _____

2.01 Bidder accepts all of the terms and conditions of the Advertisement or Invitation to Bid and Instructions to Bidders, including without limitation those dealing with the disposition of Bid security. The Bid will remain subject to acceptance for 90 days after the Bid opening, or for such longer period of time that Bidder may agree to in writing upon request of the County.

3.01 In submitting this Bid, Bidder represents, as set forth in the Agreement, that:

A. Bidder has examined and carefully studied the Bidding Documents, the other related data identified in the Bidding Documents, and the following Addenda, receipt of all which is hereby acknowledged:

| Addendum No. | Addendum Date |
|--------------|---------------|
| _____ | _____ |
| _____ | _____ |
| _____ | _____ |

- B. Bidder has visited the Site and become familiar with and is satisfied as to the general, local and Site conditions that may affect cost, progress, and performance of the Work.
- C. Bidder is familiar with and is satisfied as to all federal, state and local Laws and Regulations that may affect cost, progress and performance of the Work.
- D. Bidder has carefully studied all: (1) reports of explorations and tests of subsurface conditions at or contiguous to the Site and all drawings of physical conditions in or relating to existing surface or subsurface structures at or contiguous to the Site (except Underground Facilities) which have been identified in the Supplementary Conditions as provided in paragraph 4.02 of the General Conditions, and (2) reports and drawings of a Hazardous Environmental Condition, if any, which has been identified in the Supplementary Conditions as provided in paragraph 4.06 of the General Conditions.
- E. Bidder has obtained and carefully studied (or assumes responsibility for having done so) all additional or supplementary examinations, investigations, explorations, tests, studies, and data concerning conditions (surface, subsurface and Underground Facilities) at or contiguous to the Site which may affect costs, progress, or performance of the Work or which relate to any aspect of the means, methods, techniques, sequences, and procedures of construction to be employed by Bidder, including applying the specific means, methods, techniques, sequences, and procedures of construction expressly required by the Bidding Documents to be employed by Bidder, and safety precautions and programs incident thereto.
- F. Bidder does not consider that any further examinations, investigations, explorations, tests, studies, or data are necessary for the determination of this Bid for performance of the Work at the price(s) bid and within the times and in accordance with the other terms and conditions of the Bidding Documents.
- G. Bidder is aware of the general nature of the work to be performed by the County and others at the Site that relates to the Work as indicated in the Bidding Documents.
- H. Bidder has correlated the information known to Bidder, information and observations obtained from visits to the Site, reports and drawings identified in the Bidding Documents, and all additional examinations, investigations, explorations, tests, studies, and data with the Bidding Documents.

- I. Bidder has given the County written notice of all conflicts, errors, ambiguities, or discrepancies that Bidder has discovered in the Bidding Documents, and the written resolution thereof by the County is acceptable to Bidder.
- J. The Bidding Documents are generally sufficient to indicate and convey understanding of all terms and conditions for the performance of the Work for which this Bid is submitted.

4.01 Bidder further represents that this Bid is genuine and not made in the interest of or on behalf of any undisclosed individual or entity and is not submitted in conformity with any agreement or rules of any group, association, organization or corporation; Bidder has not directly or indirectly induced or solicited any other Bidder to submit a false or sham Bid; Bidder has not solicited or induced any individual or entity to refrain from bidding; and Bidder has not sought by collusion to obtain for itself any advantage over any other Bidder or over the County.

5.01 LUMP SUM BID: Bidder hereby proposes to furnish all labor, materials, equipment, supervision and services to perform all specified work for the above named project in strict accordance with the Contract Documents and all addenda issued thereto for the lump sum bid of:

\$ _____
(Figure)

(lump sum amount written out in words)

All specific cash allowances are included in the price(s) set forth above and have been computed in accordance with paragraph 11.02 of the General Conditions.

6.01 Bidder agrees that the Work will be substantially complete within ninety (90) calendar days after the date when the Contract Times commence to run as provided in paragraph 2.03 of the General Conditions, and completed and ready for final payment in accordance with paragraph 14.07.B of the General Conditions within thirty (30) calendar days from the date of substantial completion. Total contract time shall be one hundred twenty (120) calendar days; for everyday the work goes beyond substantial completion, a day will be removed from final completion so the total days equal one hundred twenty (120) calendar days.

6.02 Bidder accepts the provisions of the Agreement as to liquidated damages in the event of failure to complete the Work within the times specified above, which shall be stated in the Agreement.

7.01 The following documents are attached to and made a condition of this Bid:

- A. Bid Security in the form of a certified check of Bid Bond (Section 00 43 15)

- B. Tabulation of Subcontractors & Suppliers (Section 00 43 35)
- C. Florida Trench Safety Act Certification (Section 00 44 55)
- D. Bidder's Qualification Statement (Section 00 45 13)
- E. Non-collusion Affidavit (Section 00 45 19)
- F. Drug-Free Workplace Certificate (Section 00 45 20)
- G. Public Entity Crimes Statement
- H. Statement of Disputes, Litigation & Surety Completion

8.01 The terms used in this Bid with initial capital letters have the meanings indicated in the Instructions to Bidders, the General Conditions, and the Supplementary Conditions.

SUBMITTED on _____, 20_____.

State Contractor License No. _____.

If Bidder is:

An Individual

Name (typed or printed): _____

By: _____

(Individual's Signature)

Doing business as: _____

Business address: _____

Phone No.: _____

Fax No.: _____

A Partnership

Partnership Name: _____

By: _____

(Signature of general partner - attach evidence of authority to sign)

Name (typed or printed): _____

Business address: _____

Phone No.: _____ Fax No.: _____

A Corporation

Corporation Name: _____ (SEAL)

State of Incorporation: _____

Type (General Business, Professional, Service, Limited Liability): _____

By: _____

(Signature - attach evidence of authority to sign)

Name (typed or printed): _____

Title: _____ (CORPORATE SEAL)

Attest _____

(Signature of Corporate Secretary)

Business address: _____

Phone No.: _____ Fax No.: _____

Date of Qualification to do business is _____

A Joint Venture

Joint Venture Name: _____

By: _____

(Signature of joint venture partner - attach evidence of authority to sign)

Name (typed or printed): _____

Title: _____

Business address: _____

Phone No.: _____ Fax No.: _____

Joint Venture Name: _____

By: _____

(Signature - attach evidence of authority to sign)

Name (typed or printed): _____

Title: _____

Business address: _____

Phone No.: _____ Fax No.: _____

Phone and FAX Number, and Address for receipt of official communications:

(Each joint venture must sign. The manner of signing for each individual, partnership, and corporation that is a party to the joint venture should be in a manner indicated above.)

SECTION 00 43 15

BID BOND

Any singular reference to Bidder, Surety, Owner, or other party shall be considered plural where applicable.

BIDDER (Name and Address):

SURETY (Name and Address of Principal Place of Business):

OWNER (Name and Address):

BID

Bid Due Date:

Project (Brief Description Including Location):

BOND

Bond Number:

Date (Not later than Bid due date):

Penal Sum: _____ (Words) _____ (Figures)

Surety and Bidder, intending to be legally bound hereby, subject to the terms printed on the reverse side hereof, do each cause this Bid Bond to be duly executed on its behalf by its authorized officer, agent, or representative.

BIDDER

SURETY

Bidder's Name and Corporate Seal

Surety's Name and Corporate Seal

By: _____
Signature and Title

By: _____
Signature and Title
(Attach Power of Attorney)

Attest: _____
Signature and Title

Attest: _____
Signature and Title

Note: Above addresses are to be used for giving required notice.

DAMAGES FORM

1. Bidder and Surety, jointly and severally, bind themselves, their heirs, executors, administrators, successors, and assigns to pay to the County upon default of Bidder any difference between the total amount of Bidder's Bid and the total amount of the Bid of the next lowest, responsible Bidder who submitted a responsive Bid as determined by the County for the work required by the Contract Documents, provided that:

- 1.1. If there is no such next Bidder, and the County does not abandon the Project, then Bidder and Surety shall pay to the County the penal sum set forth on the face of this Bond, and
- 1.2. In no event shall Bidder's and Surety's obligation hereunder exceed the penal sum set forth on the face of this Bond.

2. Default of Bidder shall occur upon the failure of Bidder to deliver within the time required by the Bidding Documents (or any extension thereof agreed to in writing by the County) the executed Agreement required by the Bidding Documents and any performance and payment bonds required by the Bidding Documents.

3. This obligation shall be null and void if:

- 3.1. The County accepts Bidder's Bid and Bidder delivers within the time required by the Bidding Documents (or any extension thereof agreed to in writing by the County) the executed Agreement required by the Bidding Documents and any performance and payment bonds required by the Bidding Documents, or
- 3.2. All Bids are rejected by the County, or
- 3.3. The County fails to issue a Notice of Award to Bidder within the time specified in the Bidding Documents (or any extension thereof agreed to in writing by Bidder and, if applicable, consented to by Surety when required by Paragraph 5 hereof).

4. Payment under this Bond will be due and payable upon default by Bidder and within 30 calendar days after receipt by Bidder and Surety of written notice of default from the County, which notice will be given with reasonable promptness, identifying this Bond and the Project and including a statement of the amount due.

5. Surety waives notice of any and all defenses based on or arising out of any time extension to issue Notice of Award agreed to in writing by the County and Bidder, provided that the total time for issuing Notice of Award including extensions shall not in the aggregate exceed 120 days from Bid due date without Surety's written consent.

6. No suit or action shall be commenced under this Bond prior to 30 calendar days after the notice of default required in Paragraph 4 above is received by Bidder and Surety and in no case later than one year after Bid due date.

7. Any suit or action under this Bond shall be commenced only in a court of competent jurisdiction located in the state in which the Project is located.

8. Notices required hereunder shall be in writing and sent to Bidder and Surety at their respective addresses shown on the face of this Bond. Such notices may be sent by personal delivery, commercial courier, or by United States Registered or Certified Mail, return receipt requested, postage pre-paid, and shall be deemed to be effective upon receipt by the party concerned.

9. Surety shall cause to be attached to this Bond a current and effective Power of Attorney evidencing the authority of the officer, agent, or representative who executed this Bond on behalf of Surety to execute, seal, and deliver such Bond and bind the Surety thereby.

10. This Bond is intended to conform to all applicable statutory requirements. Any applicable requirement of any applicable statute that has been omitted from this Bond shall be deemed to be included herein as if set forth at length. If any provision of this Bond conflicts with any applicable statute, then the provision of said statute shall govern and the remainder of this Bond that is not in conflict therewith shall continue in full force and effect.

11. The term "Bid" as used herein includes a Bid, offer, or proposal as applicable.

SECTION 00 43 35

TABULATION OF SUBCONTRACTORS & SUPPLIERS

The undersigned states that the following is a full and complete list of the proposed subcontractors and suppliers on this Project and the class of work to be performed by each, and that such list will not be added to nor altered without written consent to the County through the Engineer.

| | <u>SUBCONTRACTOR OR SUPPLIER AND ADDRESS</u> | <u>CLASS OF WORK OR MATERIAL</u> |
|----|--|----------------------------------|
| 1. | _____ _____ | _____ |
| 2. | _____ _____ | _____ |
| 3. | _____ _____ | _____ |
| 4. | _____ _____ | _____ |
| 5. | _____ _____ | _____ |
| 6. | _____ _____ | _____ |
| 7. | _____ _____ | _____ |

BIDDER: _____

By: _____

Name: _____

Title: _____

Date: _____

SECTION 00 44 55

FLORIDA TRENCH SAFETY ACT CERTIFICATION

Bidder acknowledges that included in the various items of the proposal and in the Total Bid Price are costs for complying with the Florida Trench Safety Act (90-96, Laws of Florida) as modified October 1, 2008. The Bidder further identifies the costs to be summarized below:

| | <u>Cost</u> |
|---------------------------------|-------------|
| 1. Trench Safety Act Compliance | \$ _____ |
| 2. Special Shoring | \$ _____ |

Identify method of compliance for Item #1: _____

Identify or attach a copy of Special Shoring requirements for Item #2: _____

The undersigned certifies that he/she is the Contractor who will perform the trench excavation for this project, and hereby gives written assurance that Contractor will comply with the applicable trench safety standards specifically set forth in Florida's Trench Safety Act, Laws of Florida, 90-96.

BIDDER: _____

By: _____

Name: _____

Title: _____

Sworn to and subscribed before me this _____ day of _____, 20____.

Notary Public

My Commission Expires: _____

SECTION 00 45 13

STATEMENT OF BIDDER'S QUALIFICATIONS

To: _____ Project: _____

Date: _____

The following experience record, as of date shown, shall be submitted to the County with the Bid Form. All questions shall be answered fully. Bidders who have qualified to bid on other projects for this County within the last 12 months need not resubmit this form unless specifically requested by the County. The contents of this form will be considered confidential to the extent allowed by applicable laws and regulations.

Name of Bidder: _____

Business Address: _____

Street

City

State

Zip Code

1. Number of years in business as a Contractor under the present:
 Business Name _____
 As Principal Contractor _____ As a Sub-Contractor _____
2. Class of work you are equipped to perform: _____
3. Class of work you usually sublet: _____
4. Have any members of your concern ever operated under any other business name? _____.
 If so, give details: _____

5. Have you ever failed to qualify as a responsible bidder? _____. If so, give details.

6. Have you ever refused to enter into a contract after the award is made to you? _____.
 If so, give details. _____

7. Have you ever failed to complete any work? _____. If so, give details:

8. Has any surety or financial institution ever experienced loss on your concern? _____.

If so, give details: _____

9. Give name and address of the County, type of work, and the contract amount of at least three projects completed in the last three years:

(1)

(2)

(3)

Project Owner: _____

Owner Project Manager: _____

Email: _____

Phone No: _____

Address: _____

City, State, Zip: _____

Type of Work: _____

Contract Amt: \$ _____ \$ _____ \$ _____

10. Give name and address of the County, type of work, and contract amount of projects now in process of construction:

| | Name | Address | Type of Work | Contract Amount |
|----|-------|---------|--------------|-----------------|
| A. | _____ | _____ | _____ | \$ _____ |
| B. | _____ | _____ | _____ | \$ _____ |
| C. | _____ | _____ | _____ | \$ _____ |
| D. | _____ | _____ | _____ | \$ _____ |
| E. | _____ | _____ | _____ | \$ _____ |

11. Indicate your experience in the construction of work similar to this project (if not demonstrated by Questions 9 and 10, above):

12. Give construction experience of principal individuals of your organization:

| | Name | Position | Years of Experience | Size and Type of Work |
|----|-------|----------|---------------------|-----------------------|
| A. | _____ | _____ | _____ | _____ |

- B. _____
- C. _____
- D. _____
- E. _____

13. Are there any judgments, suits, or claims pending against you? _____. If so, give details:

14. Does your organization operate as a corporation, partnership, or individual? _____

A. If a corporation, when incorporated: _____

In which state incorporated: _____

List name, title, and address of all officers:

| | Name | Title | Address |
|-----|-------|-------|---------|
| (1) | _____ | _____ | _____ |
| (2) | _____ | _____ | _____ |
| (3) | _____ | _____ | _____ |
| (4) | _____ | _____ | _____ |
| (5) | _____ | _____ | _____ |

B. If a partnership, date of organization: _____

General, Limited, or Associated? _____

List name, address, and proportional interest of parties:

| | Name | Address | Proportional Interest |
|-----|-------|---------|-----------------------|
| (1) | _____ | _____ | _____ |
| (2) | _____ | _____ | _____ |
| (3) | _____ | _____ | _____ |
| (4) | _____ | _____ | _____ |
| (5) | _____ | _____ | _____ |

15. If requested prior to award of contract, provide to the County an accurate, up-to-date, condensed financial statement on a separate sheet attached to these qualifications of the individual, co-partnership, or corporation.

The undersigned hereby declares and certifies that the foregoing is a true statement of the experience and condition of the organization, therein first given and that any agency or individual herein named authorized to supply any information as may be deemed necessary to verify this statement.

Signed _____

Title _____

Subscribed and sworn to before me this _____

day of _____, 20____

Notary Public

_____ County, _____

My Commission expires _____

SECTION 00 45 19

NONCOLLUSION AFFIDAVIT

TO: The _____, herein called the "County."

Pursuant to bidding requirements for the work titled " _____
 _____,"

the enclosed contract documents shall be provided to the County.

State of _____

County of _____

_____, being first duly sworn,
 deposes, and says that:

- A. He is _____ (officer's title)
 of _____ (company name),
 the Bidder that has submitted the attached bid;
- B. He is fully informed respecting the preparation and contents of the attached bid and of
 all pertinent circumstances respecting such bid;
- C. Such bid is genuine and is not a collusive or sham bid;
- D. Neither the said Bidder nor any of its officers, partners, owners, agents, representatives,
 employees, or parties in interest, including this affiant, has in any way colluded,
 conspired, connived, or agreed, directly or indirectly with any other Bidder, firm, or
 person to submit a collusive or sham bid in connection with the contract for which the
 attached bid has been submitted or to refrain from bidding in connection with such
 contract, or has in any manner, directly or indirectly, sought by agreement or collusion
 or communication or conference with any other Bidder, firm, or person to fix the price
 or prices in the attached bid or of any other Bidder, or to fix any overhead, profit, or
 cost element of the bid price or the bid price of any other Bidder, or to secure through
 any collusion, conspiracy, connivance, or unlawful agreement any advantage against the
 _____ or any person interested in the proposed contract; and
- E. The price or prices quoted in the attached bid are fair and proper and are not tainted by
 any collusion, conspiracy, connivance, or unlawful agreement on the part of the Bidder
 or any of its agents, representatives, owners: employees, or parties in interest, including
 this affiant.

(Signed) _____

Subscribed and sworn to before me
this _____ day of _____, 20_____.

Notary Public

My commission expires

SECTION 00 45 20**DRUG FREE WORKPLACE CERTIFICATE**

I, the undersigned, in accordance with Florida Statute 287.087, hereby certify that _____
_____ (print or type name of firm)

- Publishes a written statement notifying that the unlawful manufacture, distribution, dispensing, possession or use of a controlled substance in the workplace named above, and specifying actions that will be taken against violations of such prohibition.
- Informs employees about the dangers of drug abuse in the workplace, the firm's policy of maintaining a drug free working environment, and available drug counseling, rehabilitation, and employee assistance programs, and the penalties that may be imposed upon employees for drug use violations.
- Gives each employee engaged in providing commodities or contractual services that are under bid or proposal, a copy of the statement specified above.
- Notifies the employees that as a condition of working on the commodities or contractual services that are under bid or proposal, the employee will abide by the terms of the statement and will notify the employer of any conviction of, plea of guilty or nolo contendere to, any violation of Chapter 1893, or any controlled substance law of the State of Florida or the United States, for a violation occurring in the work place, no later than five (5) days after such conviction, and requires employees to sign copies of such written statement to acknowledge their receipt.
- Imposes a sanction on, or requires the satisfactory participation in, a drug abuse assistance or rehabilitation program, if such is available in the employee's community, by any employee who is so convicted.
- Makes a good faith effort to continue to maintain a drug free work place through the implementation of a drug free work place program.

“As a person authorized to sign a statement, I certify that the above named business, firm, or corporation complies fully with the requirements set forth herein.”

Authorized Signature

Date Signed

State of: _____

County of: _____

Sworn to and subscribed before me this _____ day of _____, 20__.

Personally known _____ or Produced Identification _____

(Specify type of Identification)

Notary Public

My commission expires

SECTION 00 45 30

**SWORN STATEMENT UNDER SECTION 287.133(3)(a),
FLORIDA STATUTES, ON PUBLIC ENTITY CRIMES**

(To be signed in the presence of a notary public or other
officer authorized to administer oaths.)

STATE OF _____

COUNTY OF _____

Before me, the undersigned authority, personally appeared _____, who being
by me first duly sworn, made the following statement:

1. The business address of _____
(firm name of Bidder/Contractor)

is _____

2. My relationship to _____
(firm name of Bidder/Contractor)

is _____
(relationship such as sole proprietor, partner, president, vice president)

3. I understand that a public entity crime as defined in Section 287.133 of the Florida Statutes includes a violation of any state or federal law by a person with respect to and directly related to the transaction of business with any public entity in Florida or with an agency or political subdivision of any other state or with the United States, including, but not limited to, any bid or contract for goods or services to be provided to any public entity or such an agency or political subdivision and involving antitrust, fraud, theft, bribery, collusion, racketeering, conspiracy, or material misrepresentation.

4. I understand that "convicted" or "conviction" is defined by the statute to mean a finding of guilt or a conviction of a public entity crime, with or without adjudication or guilt, in any federal or state trial of record relating to charges brought by indictment or information after July 1, 1989, as a result of a jury verdict, nonjury trial, or entry of a plea of guilty or nolo contendere.

5. I understand that "affiliate" is defined by the statute to mean (1) a predecessor or successor of a person or a corporation convicted of a public entity crime; or (2) an entity under control of any natural person with is active in management of the entity and who has been convicted of a public entity crime; (3) those officers, directors, executives, partners, shareholders, employees, members, and agents who are active in the management of an affiliate; or (4) a person or corporation who knowingly entered into a joint venture with a person who has been convicted of a public entity crime in Florida during the preceding 36 months.

6. Neither the Bidder/Contractor nor any officer, director, executive, partner, shareholder, employee, member or agent who is active in the management of the Bidder/Contractor, nor any affiliate of the Bidder/Contractor, has been convicted of a public entity crime subsequent to July 1, 1989.

(Draw a line through Paragraph 6 if Paragraph 7 below applies.)

7. There has been a conviction of a public entity crime by Bidder/Contractor, or an officer, director, executive, partner, shareholder, employee, member or agent of the Bidder/Contractor who is active in the management of the Bidder/Contractor or an affiliate of the Bidder/Contractor. A determination has been made pursuant to 287.133(3) by order of the Division of Administrative Hearings that it is not in the public interest of the name of the convicted person or affiliate to appear on the convicted vendor list.

The name of the convicted person or affiliate is _____.

A copy of the order of the Division of Administrative Hearings is attached to this statement.

(Draw a line through Paragraph 7 if Paragraph 6 above applies.)

(Signature)

Sworn to and subscribed before me in the State and County first mentioned above on the _____ day of _____, 20__.

Notary Public

(affix seal)

My commission expires

SECTION 00 45 35

**BIDDER'S STATEMENT OF DISPUTES, LITIGATION, ARBITRATION,
AND SURETY COMPLETION, LAST THREE (3) YEARS**

| <u>Project</u> | <u>Name and Address of Owner or Engineer</u> | <u>Name and Phone of Owner or Engineer Representative</u> | <u>Date of Contract</u> | <u>Amount</u> | <u>Status</u> |
|----------------|--|---|-----------------------------|---------------|---------------|
|----------------|--|---|-----------------------------|---------------|---------------|

(Signed) _____

Print Name _____

Subscribed and sworn to before me
this _____ day of _____, 20

Notary Public

My commission expires :

SECTION 00 51 00

NOTICE OF AWARD

TO: _____

CONTRACTOR

ADDRESS

CITY STATE ZIP

PROJECT: _____

NAME

The Nassau County Board of County Commissioners has considered the recommendation to accept the Bid submitted by _____ for the above described work in response to its Invitation to Bid (ITB), Bid No. NC19-026, opened on _____, 2019.

You are hereby notified that the Bid has been accepted and the Nassau County Board of County Commissioners has executed the enclosed agreement subject to: Receipt of the applicable bonds and Certificate(s) of Insurance, within ten (10) calendar days from the date of this Notice of Award and receipt of the fully executed agreement. The bonds are required to be recorded at cost to the contractor. The bonds must be recorded within the same ten (10) day period referenced herein. The Clerk of Courts does not accept company or personal checks unless the signee is present and can provide identification.

If you fail to furnish the bonds and the Certificate of Insurance within ten (10) calendar days from the date of this Notice, the County will be entitled to consider any rights arising out of the County's acceptance of your Bid as abandoned and void.

You are required to return an acknowledged copy of this Notice of Award, Bonds, and Insurance Certificates to the Nassau County Board of County Commissioners, c/o John A. Crawford, Ex-Officio Clerk, 76347 Veterans Way, Yulee, Florida 32097. A copy must be sent to Nassau County, Procurement Manager, at 96135 Nassau Place, Suite 6, Yulee, Florida 32097.

Dated this _____ day _____, 2019.

Nassau County Board of County Commissioners

BY: _____

TITLE: _____

ACCEPTANCE OF NOTICE

Receipt of the above Notice of Award is hereby acknowledged by _____
this _____ day of _____, 2019.

BY: _____ TITLE: _____

SECTION 00 52 15**SAMPLE AGREEMENT**

Will be subject to review and modification by the County Attorney's Office

AGREEMENT

THIS AGREEMENT is dated as of the _____ day of _____ in the year 2019 by and between _____ (County) and _____ (Contractor).

County and Contractor, in consideration of the mutual covenants hereinafter set forth, agree as follows:

ARTICLE 1 - WORK

1.01 Contractor shall complete all Work as specified or indicated in the Contract Documents. The Work is generally described as follows:

All work shall be in accordance with the construction drawings, specifications, and contract documents.

ARTICLE 2 - THE PROJECT

2.01 The Project for which the Work under the Contract Documents may be the whole or only a part is generally described as follows:

**Animal Services Cattery Addition
Bid Number NC19-026
Nassau County, Florida**

ARTICLE 3 - ENGINEER OF RECORD / MANAGING AUTHORITY

3.01 The Project has been designed by Gillette & Associates, Inc., who is to act as the County's representative, assume all duties and responsibilities, and have the rights and authority assigned to Engineer of Record in the Contract Documents in connection with completion of the Work in accordance with the Contract Documents.

3.02 The Project Manager for this project shall be the Nassau County Facilities Maintenance Director, Douglas Podiak or his authorized designee.

ARTICLE 4 - CONTRACT TIMES

4.01 Time of the Essence

- A. All time limits for Milestones, if any, Substantial Completion, and completion and readiness for final payment as stated in the Contract Documents are of the essence of the Contract.
- B. The Contractor hereby agrees to commence work under this contract on a date to be specified in written "Notice to Proceed" of the County and to fully complete the project as specified in Section 4.02 of this Agreement.

4.02 Days to Achieve Substantial Completion and Final Payment

The Work will be substantially completed within ninety (90) days after the date when the Contract Times commence to run as provided in Paragraph 2.03 of the General Conditions, and completed and ready for final payment in accordance with Paragraph 14.07 of the General Conditions within thirty (30) calendar days from the date of substantial completion. Total contract time shall be one hundred twenty (120) calendar days; for everyday the work goes beyond substantial completion, a day will be removed from final completion so the total days equal one hundred twenty (120) calendar days.

4.03 Liquidated Damages

- A. Contractor and the County recognize that time is of the essence of this Agreement and that the County will suffer financial loss if the Work is not completed within the times specified in Paragraph 4.02 above, plus any extensions thereof allowed in accordance with Article 12 of the General Conditions. The parties also recognize the delays, expense, and difficulties involved in proving in legal or arbitration proceeding the actual loss suffered by the County if the Work is not completed on time. Accordingly, instead of requiring any such proof, the County and Contractor agree that as liquidated damages for delay (but not as a penalty) Contractor shall pay the County \$50.00 for each day that expires after the time specified in Paragraph 4.02 for Substantial Completion and until the Work is substantially complete. After Substantial Completion, if Contractor shall neglect, refuse, or fail to complete the remaining Work within the Contract Time or any proper extension thereof granted by the County, Contractor shall pay the County \$50.00 for each day that expires after the time specified in Paragraph 4.02 for completion and readiness for final payment until the Work is completed and ready for final payment.

ARTICLE 5 - CONTRACT PRICE

- 5.01** The County shall pay Contractor for completion of the Work in accordance with the Contract Documents an amount in current funds equal to the sum of the amounts determined pursuant to Paragraph 25 "Payments to Contractor" of the General Conditions and Paragraphs 5.01A and 5.01 B below:

- A. For all Work, at the prices stated in the Contractor's Bid, attached hereto as an exhibit.

As provided in Paragraph 11.03 of the General Conditions, estimated quantities are not guaranteed, and determinations of actual quantities and classification are to be made by Engineer of Record as provided in paragraph 9.07 of the General Conditions. The final payment for all Unit Price Work shall be an amount equal to the sum of the established unit price for each separately identified item of Unit Price Work times the actual completed and accepted quantity of each item. Unit prices have been computed as provided in Paragraph 11.03 of the General Conditions.

ARTICLE 6 - PAYMENT PROCEDURES

6.01 Submittal and Processing of Payments

- A. Contractor shall submit Applications for Payment in accordance with Article 14 of the General Conditions. Applications for Payment will be processed by the County as provided in the General Conditions.

6.02 Progress Payments; Retainage

- A. The County shall make progress payments on account of the Contract Price on the basis of Contractor's Applications for Payment once each month during performance of the Work as provided in Paragraphs 6.02.A.1 and 6.02.A.2 below. All such payments will be measured by the schedule of values established as provided in Paragraph 2.07.A of the General Conditions (and in the case of Unit Price Work based on the number of units completed) or, in the event there is no schedule of values, as provided in the General Requirements:
1. Prior to Substantial Completion, progress payments will be made in an amount equal to the percentage indicated below, but, in each case, less the aggregate of payments previously made and less such amounts as Engineer of Record may determine or the County may withhold, including but not limited to liquidated damages, in accordance with Paragraph 14.02 of the General Conditions:
 - a. 90% percent of the Work completed (with the balance being retainage)
 - b. 90% percent of cost of materials and equipment not incorporated in the Work (with the balance being retainage).
 2. Upon Substantial Completion, the County shall pay an amount sufficient to increase total payments to Contractor to 95% percent of the Contract Price (with the balance being retainage), less such amounts as Engineer of Record shall determine or the County

may withhold, for incomplete work and for other items in accordance with Paragraph 14.02 of the General Conditions.

6.03 Final Payment

- A. Upon final completion and acceptance of the Work in accordance with Paragraph 14.07 of the General Conditions, the County shall pay the remainder of the Contract Price as recommended by Project Manager and Engineer of Record as provided in said Paragraph 14.07.
- B. Final Release of Retainage and acceptance of the project must be approved by the Board of County Commissioners.

ARTICLE 7 - INTEREST

- 7.01** All moneys not paid when due as provided in Article 14 of the General Conditions shall bear interest at the rate of 0 percent per annum.

ARTICLE 8 - CONTRACTOR'S REPRESENTATIONS

- 8.01** In order to induce the County to enter into this Agreement, the Contractor makes the following representations:
- A. Contractor has examined and carefully studied the Contract Documents and the other related data identified in the Bidding Documents.
 - B. Contractor has visited the Site and become familiar with and is satisfied as to the general, local, and Site conditions that may affect cost, progress, and performance of the Work.
 - C. Contractor is familiar with and is satisfied as to all federal, state, and local Laws and Regulations that may affect cost, progress, and performance of the Work.
 - D. Contractor has carefully studied all: (1) reports of explorations and tests of subsurface conditions at or contiguous to the Site and all drawings of physical conditions in or relating to existing surface or subsurface structures at or contiguous to the Site (except Underground Facilities) which have been identified in the Supplementary Conditions as provided in Paragraph 4.02 of the General Conditions and (2) reports and drawings of a Hazardous Environmental Condition, if any, at the Site which has been identified in the Supplementary Conditions as provided in Paragraph 4.06 of the General Conditions.
 - E. Contractor has obtained and carefully studied (or assumes responsibility for having done so) all additional or supplementary examinations, investigations, explorations, tests, studies,

- and data concerning conditions (surface, subsurface, and Underground Facilities) at or contiguous to the Site which may affect cost, progress, or performance of the Work or which relate to any aspect of the means, methods, techniques, sequences, and procedures of construction to be employed by Contractor, including applying the specific means, methods, techniques, sequences, and procedures of construction, if any, expressly required by the Bidding Documents, and safety precautions and programs incident thereto.
- F. Contractor does not consider that any additional examinations, investigations, explorations, tests, studies, or data are necessary for the performance of the Work at the Contract Price, within the Contract Times, and in accordance with the other terms and conditions of the Contract Documents.
- G. Contractor is aware of the general nature of work to be performed by the County and others at the Site that relates to the Work as indicated in the Contract Documents.
- H. Contractor has correlated the information known to Contractor, information and observations obtained from visits to the Site, reports and drawings identified in the Contract Documents, and all additional examinations, investigations, explorations, tests, studies, and data with the Contract Documents.
- I. Contractor has given the County written notice of all conflicts, errors, ambiguities, or discrepancies that Contractor has discovered in the Contract Documents, and the written resolution thereof by the County is acceptable to Contractor.
- J. The Contract Documents are generally sufficient to indicate and convey understanding of all terms and conditions for performance of the Work.

ARTICLE 9 - CONTRACT DOCUMENTS

9.01 Contents

- A. The Contract Documents consist of the following:
1. This Agreement
 2. Project Manual (enumerated as follows):
 - a. Project Manual Table of Contents
 - b. General Conditions
 - c. Supplementary Conditions
 - d. Technical Specifications
 - e. Appendixes
 - f. Addenda, if any
 3. Exhibits to this Agreement:

- a. General Information and Minimum Insurance Requirements
4. Documentation submitted by Contractor prior to Notice of Award
5. Drawing Index, if any
6. The following which may be delivered or issued on or after the Effective Date of the Agreement and are not attached hereto:
 - a. Payment Bond
 - b. Performance Bond
 - c. Certificate of Liability Insurance
 - d. Notice to Proceed
 - e. Work Change Directives
 - f. Change Orders
 - g. Certificate of Substantial Completion
 - h. Certificate of Final Inspection
 - i. Certificate of Engineer
 - j. Certificate of Final Completion
 - k. CONTRACTOR'S release of Performance Bond
 - l. Construction Drawings and plans/As-Built Drawings
 - m. Supplemental Agreements
 - n. CONTRACTOR'S Waiver of Lien (Partial)
 - o. CONTRACTOR'S Waiver of Lien (Final and Complete)
 - p. Subcontractor/Vendor's Waiver of Lien (Final and Complete)
 - q. Consent of Surety to Final Payment
 - r. Contractors Insurance Requirements, as set for in the Bid Documents
- B. The documents listed in Paragraph 9.01.A are attached to this Agreement (except as expressly noted otherwise above).
- C. There are no Contract Documents other than those listed above in this Article 9
- D. The Contract Documents may only be amended, modified, or supplemented as provided in paragraph 3.04 of the General Conditions.

ARTICLE 10 - MISCELLANEOUS

10.01 Terms

- A. Terms used in this Agreement will have the meanings indicated in the General Conditions and the Supplementary Conditions.

10.02 Assignment of Agreement

- A. No assignment by a party hereto of any rights under or interests in the Agreement will be binding on another party hereto without the written consent of the party sought to be bound; and, specifically but without limitation, moneys that may become due and moneys that are due may not be assigned without such consent (except to the extent that the effect of this restriction may be limited by law), and unless specifically stated to the contrary in any written consent to an assignment, no assignment will release or discharge the assignor from any duty or responsibility under the Contract Documents.

10.03 Successors and Assigns

- A. The County and Contractor each binds itself, its partners, successors, assigns, and legal representatives to the other party hereto, its partners, successors, assigns, and legal representatives in respect to all covenants, agreements, and obligations contained in the Contract Documents.

10.04 Severability

- A. Any provision or part of the Contract Documents held to be void or unenforceable under any Law or Regulation shall be deemed stricken, and all remaining provisions shall continue to be valid and binding upon the County and Contractor, who agree that the Contract Documents shall be reformed to replace such stricken provision or part thereof with a valid and enforceable provision that comes as close as possible to expressing the intention of the stricken provision.

10.05 Other Provisions

A. Public Records Requirement:

The County is a public agency subject to Chapter 119, Florida Statutes. IF THE CONTRACTOR HAS QUESTIONS REGARDING THE APPLICATION OF CHAPTER 119, FLORIDA STATUTES, TO THE CONTRACTOR'S DUTY TO PROVIDE PUBLIC RECORDS RELATING TO THIS AGREEMENT, CONTACT THE CUSTODIAN OF PUBLIC RECORDS AT (904) 530-6250, DMOODY@NASSAUCOUNTYFL.COM, 96161 NASSAU PLACE, YULEE, FLORIDA 32097. Under this agreement, to the extent that the contractor is providing services to the County, and pursuant to Section 119.0701, Florida Statutes, the contractor shall;

- a. Keep and maintain public records required by the public agency to perform the service.
- b. Upon request from the public agency's custodian of public records, provide the public agency with a copy of the requested records or allow the records to be inspected or copied within a reasonable time at a cost that does not exceed the cost

- provided in this chapter or as otherwise provided by law.
- c. Ensure that public records that are exempt or confidential and exempt from public records disclosure requirements are not disclosed except as authorized by law for the duration of the contract term and following completion of the Agreement if the contractor does not transfer the records to the public agency.
 - d. Upon completion of the Agreement, transfer, at no cost, to the public agency all public records in possession of the contractor or keep and maintain public records required by the public agency to perform the service. If the contractor transfers all public records to the public agency upon completion of the Agreement, the contractor shall destroy any duplicate public records that are exempt or confidential and exempt from public records disclosure requirements. If the contractor keeps and maintains public records upon completion of the Agreement, the contractor shall meet all applicable requirements for retaining public records. All records stored electronically must be provided to the public agency, upon request from the public agency's custodian of public records, in a format that is compatible with the information technology systems of the public agency

[Remainder of page intentionally left blank]

IN WITNESS WHEREOF, the County and Contractor have signed this Agreement in triplicate. One counterpart each has been delivered to the County, Contractor, and Engineer of Record. All portions of the Contract Documents have been signed or identified by the County and Contractor or identified by Engineer of Record on their behalf.

This Agreement will be effective on the date on which the Agreement is signed and delivered by the last of the two parties to sign and deliver (which is the Effective Date of the Agreement).

COUNTY

CONTRACTOR

Nassau County Board of County Commissioners

Signed: _____

Signed: _____

Title: _____

Title: _____

Date: _____

Date: _____

[CORPORATE SEAL]

[CORPORATE SEAL]

Attest: _____

Attest: _____

Title: _____

Title: _____

Address for giving notices:

Address for giving notices:

Phone: _____ FAX: _____

Phone: _____ FAX: _____

License _____

(Where applicable)

Approved as to form by County Attorney

Agent for service of process:

Signature

(If Contractor is a corporation or a partnership, attach evidence of authority to sign.)

SECTION 00 55 00

NOTICE TO PROCEED

TO: _____
 CONTRACTOR

 ADDRESS

 CITY STATE ZIP

PROJECT: Animal Services Cattery Addition
 Contract No. CMXXXX/Bid Number NC19-026
 Nassau County, Florida

You are hereby notified to commence work in accordance with the Agreement dated _____, 2019.

The Contract time for Substantial Completion is _____ consecutive calendar days from the date of commencement.

The Contract time for Final Completion is _____ consecutive calendar days from the date of Substantial Completion.

The Contract time commences to run _____, 2019.

The date of Substantial Completion is _____, 2019.

The date of Final Completion is _____, 2019.

Nassau County Board of County Commissioners

BY: _____

TITLE: _____

DATE: _____

You are required to return an acknowledged copy of the Notice to Proceed to The Nassau County Board of County Commissioners, c/o John A. Crawford, Ex-Officio Clerk, 76347 Veterans Way, Suite 456, Yulee, Florida 32097.

ACCEPTANCE OF NOTICE

Receipt of the above Notice to Proceed is hereby acknowledged

this _____ day of _____, 2019.

BY: _____

TITLE: _____

SECTION 00 61 15

PERFORMANCE BOND

Any singular reference to Contractor, Surety, Owner, or other party shall be considered plural where applicable.

CONTRACTOR (*Name and Address*):

SURETY (*Name, and Address of Principal Place of Business*):

OWNER (*Name and Address*):

CONTRACT

Effective Date of Agreement:

Amount:

Description (*Name and Location*):

BOND

Bond Number:

Date (*Not earlier than Effective Date of Agreement*):

Amount:

Modifications to this Bond Form:

Surety and Contractor, intending to be legally bound hereby, subject to the terms set forth below, do each cause this Performance Bond to be duly executed by an authorized officer, agent, or representative.

CONTRACTOR AS PRINCIPAL

SURETY

Contractor's Name and Corporate Seal

Surety's Name and Corporate Seal

By: _____
Signature

By: _____
Signature (Attach Power of Attorney)

Print Name

Print Name

Title

Title

Attest: _____
Signature

Attest: _____
Signature

Title

Title

Note: Provide execution by additional parties, such as joint ventures, if necessary.

EJCDC No. C-610 (2007 Edition)

Originally prepared through the joint efforts of the Surety Association of America, Engineers Joint Contract Documents Committee, the Associated General Contractors of America, and the American Institute of Architects.

Contractor and Surety, jointly and severally, bind themselves, their heirs, executors, administrators, successors, and assigns to Owner for the performance of the Contract, which is incorporated herein by reference.

1. If Contractor performs the Contract, Surety and Contractor have no obligation under this Bond, except to participate in conferences as provided in Paragraph 2.1.
2. If there is no Owner Default, Surety's obligation under this Bond shall arise after:
 - 2.1 Owner has notified Contractor and Surety, at the addresses described in Paragraph 9 below, that Owner is considering declaring a Contractor Default and has requested and attempted to arrange a conference with Contractor and Surety to be held not later than 15 days after receipt of such notice to discuss methods of performing the Contract. If Owner, Contractor, and Surety agree, Contractor shall be allowed a reasonable time to perform the Contract, but such an agreement shall not waive Owner's right, if any, subsequently to declare a Contractor Default; and
 - 2.2 Owner has declared a Contractor Default and formally terminated Contractor's right to complete the Contract. Such Contractor Default shall not be declared earlier than 20 days after Contractor and Surety have received notice as provided in Paragraph 2.1; and
 - 2.3 Owner has agreed to pay the Balance of the Contract Price to:
 1. Surety in accordance with the terms of the Contract; or
 2. Another contractor selected pursuant to Paragraph 3.3 to perform the Contract.
3. When Owner has satisfied the conditions of Paragraph 2, Surety shall promptly, and at Surety's expense, take one of the following actions:
 - 3.1 Arrange for Contractor, with consent of Owner, to perform and complete the Contract; or
 - 3.2 Undertake to perform and complete the Contract itself, through its agents or through independent contractors; or
 - 3.3 Obtain bids or negotiated proposals from qualified contractors acceptable to Owner for a contract for performance and completion of the Contract, arrange for a contract to be prepared for execution by Owner and contractor selected with Owner's concurrence, to be secured with performance and payment bonds executed by a qualified surety equivalent to the bonds issued on the Contract, and pay to Owner the amount of damages as described in Paragraph 5 in excess of the Balance of the Contract Price incurred by Owner resulting from Contractor Default; or
 - 3.4 Waive its right to perform and complete, arrange for completion, or obtain a new contractor, and with reasonable promptness under the circumstances:
 1. After investigation, determine the amount for which it may be liable to Owner and, as soon as practicable after the amount is determined, tender payment therefor to Owner; or
 2. Deny liability in whole or in part and notify Owner citing reasons therefor.
4. If Surety does not proceed as provided in Paragraph 3 with reasonable promptness, Surety shall be deemed to be in default on this Bond 15 days after receipt of an additional written notice from Owner to Surety demanding that Surety perform its obligations under this Bond, and Owner shall be entitled to enforce any remedy available to Owner. If Surety proceeds as provided in Paragraph 3.4, and Owner refuses the payment tendered or Surety has denied

liability, in whole or in part, without further notice Owner shall be entitled to enforce any remedy available to Owner.

5. After Owner has terminated Contractor's right to complete the Contract, and if Surety elects to act under Paragraph 3.1, 3.2, or 3.3 above, then the responsibilities of Surety to Owner shall not be greater than those of Contractor under the Contract, and the responsibilities of Owner to Surety shall not be greater than those of Owner under the Contract. To the limit of the amount of this Bond, but subject to commitment by Owner of the Balance of the Contract Price to mitigation of costs and damages on the Contract, Surety is obligated without duplication for:

- 5.1 The responsibilities of Contractor for correction of defective Work and completion of the Contract;
- 5.2 Additional legal, design professional, and delay costs resulting from Contractor's Default, and resulting from the actions of or failure to act of Surety under Paragraph 3; and
- 5.3 Liquidated damages, or if no liquidated damages are specified in the Contract, actual damages caused by delayed performance or non-performance of Contractor.

6. Surety shall not be liable to Owner or others for obligations of Contractor that are unrelated to the Contract, and the Balance of the Contract Price shall not be reduced or set off on account of any such unrelated obligations. No right of action shall accrue on this Bond to any person or entity other than Owner or its heirs, executors, administrators, or successors.

7. Surety hereby waives notice of any change, including changes of time, to Contract or to related subcontracts, purchase orders, and other obligations.

8. Any proceeding, legal or equitable, under this Bond may be instituted in any court of competent jurisdiction in the location in which the Work or part of the Work is located, and shall be instituted within two years after Contractor Default or within two years after Contractor ceased working or within two years after Surety refuses or fails to perform its obligations under this Bond, whichever occurs first. If the provisions of this paragraph are void or prohibited by law, the minimum period of limitation available to sureties as a defense in the jurisdiction of the suit shall be applicable.

9. Notice to Surety, Owner, or Contractor shall be mailed or delivered to the address shown on the signature page.

10. When this Bond has been furnished to comply with a statutory requirement in the location where the Contract was to be performed, any provision in this Bond conflicting with said statutory requirement shall be deemed deleted herefrom and provisions conforming to such statutory requirement shall be deemed incorporated herein. The intent is that this Bond shall be construed as a statutory bond and not as a common law bond.

11. Definitions.

- 11.1 Balance of the Contract Price: The total amount payable by Owner to Contractor under the Contract after all proper adjustments have been made, including allowance to Contractor of any amounts received or to be received by Owner in settlement of

insurance or other Claims for damages to which Contractor is entitled, reduced by all valid and proper payments made to or on behalf of Contractor under the Contract.

11.2 Contract: The agreement between Owner and Contractor identified on the signature page, including all Contract Documents and changes thereto.

11.3 Contractor Default: Failure of Contractor, which has neither been remedied nor waived, to perform or otherwise to comply with the terms of the Contract.

11.4 Owner Default: Failure of Owner, which has neither been remedied nor waived, to pay Contractor as required by the Contract or to perform and complete or otherwise comply with the other terms thereof.

FOR INFORMATION ONLY – *(Name, Address and Telephone)*

Surety Agency or Broker:

Owner's Representative *(Engineer or other party)*:

SECTION 00 61 16
PAYMENT BOND

Any singular reference to Contractor, Surety, Owner, or other party shall be considered plural where applicable.

CONTRACTOR (*Name and Address*):

SURETY (*Name, and Address of Principal Place of Business*):

OWNER (*Name and Address*):

CONTRACT

Effective Date of Agreement:

Amount:

Description (*Name and Location*):

BOND

Bond Number:

Date (*Not earlier than Effective Date of Agreement*):

Amount:

Modifications to this Bond Form:

Surety and Contractor, intending to be legally bound hereby, subject to the terms set forth below, do each cause this Payment Bond to be duly executed by an authorized officer, agent, or representative.

CONTRACTOR AS PRINCIPAL

SURETY

Contractor's Name and Corporate Seal

(Seal)

Surety's Name and Corporate Seal

(Seal)

By: _____
Signature

By: _____
Signature (Attach Power of Attorney)

Print Name

Print Name

Title

Title

Attest: _____
Signature

Attest: _____
Signature

Title

Title

Note: Provide execution by additional parties, such as joint ventures, if necessary.

EJCDC No. C-615(A) (2007 Edition)

Originally prepared through the joint efforts of the Surety Association of America, Engineers Joint Contract Documents Committee, the Associated General Contractors of America, the American Institute of Architects, the American Subcontractors Association, and the Associated Specialty Contractors.

1. Contractor and Surety, jointly and severally, bind themselves, their heirs, executors, administrators, successors, and assigns to Owner to pay for labor, materials, and equipment furnished by Claimants for use in the performance of the Contract, which is incorporated herein by reference.
2. With respect to Owner, this obligation shall be null and void if Contractor:
 - 2.1 Promptly makes payment, directly or indirectly, for all sums due Claimants, and
 - 2.2 Defends, indemnifies, and holds harmless Owner from all claims, demands, liens, or suits alleging non-payment by Contractor by any person or entity who furnished labor, materials, or equipment for use in the performance of the Contract, provided Owner has promptly notified Contractor and Surety (at the addresses described in Paragraph 12) of any claims, demands, liens, or suits and tendered defense of such claims, demands, liens, or suits to Contractor and Surety, and provided there is no Owner Default.
3. With respect to Claimants, this obligation shall be null and void if Contractor promptly makes payment, directly or indirectly, for all sums due.
4. Surety shall have no obligation to Claimants under this Bond until:
 - 4.1 Claimants who are employed by or have a direct contract with Contractor have given notice to Surety (at the address described in Paragraph 12) and sent a copy, or notice thereof, to Owner, stating that a claim is being made under this Bond and, with substantial accuracy, the amount of the claim.
 - 4.2
 - 4.3 Claimants who do not have a direct contract with Contractor:
 1. Have furnished written notice to Contractor and sent a copy, or notice thereof, to Owner, within 90 days after having last performed labor or last furnished materials or equipment included in the claim stating, with substantial accuracy, the amount of the claim and the name of the party to whom the materials or equipment were furnished or supplied, or for whom the labor was done or performed; and
 2. Have either received a rejection in whole or in part from Contractor, or not received within 30 days of furnishing the above notice any communication from Contractor by which Contractor had indicated the claim will be paid directly or indirectly; and
 3. Not having been paid within the above 30 days, have sent a written notice to Surety (at the address described in Paragraph 12) and sent a copy, or notice thereof, to Owner, stating that a claim is being made under this Bond and enclosing a copy of the previous written notice furnished to Contractor.
5. If a notice by a Claimant required by Paragraph 4 is provided by Owner to Contractor or to Surety, that is sufficient compliance.
6. Reserved.
7. Surety's total obligation shall not exceed the amount of this Bond, and the amount of this Bond shall be credited for any payments made in good faith by Surety.
8. Amounts owed by Owner to Contractor under the Contract shall be used for the performance of the Contract and to satisfy claims, if any, under any performance bond. By Contractor furnishing and Owner accepting this Bond, they agree that all funds earned by Contractor in the performance of the Contract are dedicated to satisfy obligations of Contractor and Surety under this Bond, subject to Owner's priority to use the funds for the completion of

the Work.

9. Surety shall not be liable to Owner, Claimants, or others for obligations of Contractor that are unrelated to the Contract. Owner shall not be liable for payment of any costs or expenses of any Claimant under this Bond, and shall have under this Bond no obligations to make payments to, give notices on behalf of, or otherwise have obligations to Claimants under this Bond.

10. Surety hereby waives notice of any change, including changes of time, to the Contract or to related subcontracts, purchase orders, and other obligations.

11. No suit or action shall be commenced by a Claimant under this Bond other than in a court of competent jurisdiction in the location in which the Work or part of the Work is located or after the expiration of one year from the date (1) on which the Claimant gave the notice required by Paragraph 4.1 or Paragraph 4.2.3, or (2) on which the last labor or service was performed by anyone or the last materials or equipment were furnished by anyone under the Contract, whichever of (1) or (2) first occurs. If the provisions of this paragraph are void or prohibited by law, the minimum period of limitation available to sureties as a defense in the jurisdiction of the suit shall be applicable.

12. Notice to Surety, Owner, or Contractor shall be mailed or delivered to the addresses shown on the signature page. Actual receipt of notice by Surety, Owner, or Contractor, however accomplished, shall be sufficient compliance as of the date received at the address shown on the signature page.

13. When this Bond has been furnished to comply with a statutory requirement in the location where the Contract was to be performed, any provision in this Bond conflicting with said statutory requirement shall be deemed deleted herefrom and provisions conforming to such statutory requirement shall be deemed incorporated herein. The intent is that this Bond shall be construed as a statutory Bond and not as a common law bond.

14. Upon request of any person or entity appearing to be a potential beneficiary of this Bond, Contractor shall promptly furnish a copy of this Bond or shall permit a copy to be made.

15. Definitions

15.1 Claimant: An individual or entity having a direct contract with Contractor, or with a first-tier subcontractor of Contractor, to furnish labor, materials, or equipment for use in the performance of the Contract. The intent of this Bond shall be to include without limitation in the terms "labor, materials or equipment" that part of water, gas, power, light, heat, oil, gasoline, telephone service, or rental equipment used in the Contract, architectural and engineering services required for performance of the Work of Contractor and Contractor's subcontractors, and all other items for which a mechanic's lien may be asserted in the jurisdiction where the labor, materials, or equipment were furnished.

15.2 Contract: The agreement between Owner and Contractor identified on the signature page, including all Contract Documents and changes thereto.

15.3 Owner Default: Failure of Owner, which has neither been remedied nor waived, to pay Contractor as required by the Contract, or to perform and complete or otherwise comply with the other terms thereof.

FOR INFORMATION ONLY – *(Name, Address, and Telephone)*

Surety Agency or Broker:

Owner's Representative *(Engineer or other)*:

SECTION 00 62 76

APPLICATION AND CERTIFICATE FOR PROGRESS PAYMENT

COUNTY: _____

CONTRACTOR: _____

Purchase Order No.: _____ Project Title: _____

Engineer/Architect: _____

Engineer/Architect Project No.: _____ Contract Number: _____

Progress Payment No.: _____ for Period _____ to _____

- 1. Original Contract Sum. \$ _____
- 2. Net Change by Change Orders \$ _____
- 3. Contract Sum to Date (Line 1 + Line 2) \$ _____
- 4. Work Completed to Date \$ _____
- 5. Amount Retained (Percent) \$ _____
- 6. Total Earned Less Retainage (Line 4 minus Line 5). \$ _____
- 7. Less Previous Payments. \$ _____
- 8. CURRENT PAYMENT DUE. \$ _____

CERTIFICATION OF CONTRACTOR

The undersigned CONTRACTOR certifies that (1) all previous progress payments received from OWNER on account of Work done under the Contract referred to above have been applied on account to discharge CONTRACTOR'S legitimate obligations incurred in connection with Work covered by prior Applications for Payment numbered 1 through _____ inclusive; (2) title of all Work, materials and equipment incorporated in said Work or otherwise listed in or covered by this Application for Payment will pass to the COUNTY at time of payment free and clear of all Liens, security interests and encumbrances (except such as are covered by a Bond acceptable to the COUNTY indemnifying the COUNTY against any such Lien, security interest or encumbrance); and (3) all Work covered by this Application for Payment is in accordance with the Contract Documents and is not defective.

 Contractor Date
 By: _____ Title
 (Authorized Representative)

CERTIFICATION OF ENGINEER / ARCHITECT

In accordance with the Contract Documents, based upon on-site observations by the undersigned or duly authorized representatives or assistants, the Engineer / Architect and/or Project Manager certifies to the County that to the best of its knowledge, information and belief, the Work has progressed as indicated, the quality of the Work is in accordance with the Contract Documents and the Contractor is entitled to payment of the AMOUNT CERTIFIED.

AMOUNT CERTIFIED:.....\$ _____
(Attach explanation if amount certified differs from the amount applied for)

ENGINEER / ARCHITECT/ PROJECT MANAGER:

By: _____
(Date) (Firm)

AFFIDAVIT OF CONTRACTOR

STATE OF _____

COUNTY OF _____

Before me this day personally appeared _____ who, being first duly sworn, deposes and says:

That he is the _____ of _____, and the Contractor on the following described public works project:

JOB DESCRIPTION: _____

CONTRACTING AUTHORITY: Nassau County Board of County Commissioners

That all persons who furnish labor, supplies or materials or did work in connection with such improvements set out in the CONTRACT have been paid, to date, in full, including all subcontractors.

AND FURTHER AFFIANT SAYETH NOT.

By: _____

WITNESS my hand and official seal, this _____ day of _____, 20_____.

Notary Public
My Commission Expires:

SECTION 00 63 15

CONTRACTOR'S REQUEST FOR INFORMATION

TO: _____

FROM: _____ (CONTRACTOR) DATE: _____

CONTRACTOR REQUEST FOR INFORMATION NO.: _____

PROJECT NAME: _____

CONTRACT NUMBER: _____ PURCHASE ORDER NO.: _____

QUESTION:

BY: _____ DATE: _____

REPLY:

BY: _____ DATE: _____

SECTION 00 63 36

FIELD ORDER

PROJECT: _____ REQUEST NO: _____

CONTRACT NO.: _____ PURCHASE ORDER NO.: _____

CONTRACTOR: _____

You are hereby directed to execute promptly this Field Order which interprets the Contract Documents or orders minor changes in the Work without change in Contract Price or Contract Time.

If you consider that a change in Contract Price or Contract Time is required, please submit a Work Change Directive to the COUNTY immediately and before proceeding with this Work.

Field Order: _____

Attachments: (Listing of attached documents that support description)

1. Work Change Directive No _____

2. _____

3. _____

4. _____

5. _____

BY: _____ DATE: _____

SECTION 00 63 49

WORK CHANGE DIRECTIVE

PROJECT: _____ REQUEST NO: _____

CONTRACT NO.: _____ PURCHASE ORDER NO.: _____

CONTRACTOR: _____

You are directed to proceed promptly with the following change(s):

Description: _____

Purpose of Work Directive Change: _____

Attachments: _____

If a claim is made that the above change(s) have affected the Contract Price or Contract Time, any claim for a Change Order based thereon will involve one of the following methods of determining the effect of the change(s).

Method of determining a change in Contract Price:

- Time and materials
- Unit prices
- Cost plus fixed fee
- Other _____

Estimated increase (decrease) in Contract Price: \$ _____

If the change involves an increase, the estimated amount is not to be exceeded without further authorization.

Method of determining change in Contract Time:

- Contractor's records
- COUNTY's records
- Other _____

Estimated increase (decrease) in Contract Time: _____ days.

If the change involves an increase, the estimated time is not to be exceeded without further authorization.

AUTHORIZED BY:

DATE:

SECTION 00 63 63

CHANGE ORDER REQUEST FORM

(instructions on 00 63 63-2)

No. _____

PROJECT

DATE OF ISSUANCE

EFFECTIVE DATE

NASSAU COUNTY BOARD OF COUNTY COMMISSIONERS

COUNTY Contract / Purchase Order No.:

CONTRACTOR-

ENGINEER / ARCHITECT-

You are directed to make the following changes in the Contract Documents.

Attachments: (List documents supporting change)

| | |
|--|---|
| <p>CHANGE IN CONTRACT PRICE:</p> <p>Original Contract Price</p> <p>\$ _____</p> | <p>CHANGE IN CONTRACT TIMES:</p> <p>Original Contract Times _____</p> <p>Ready for Final Payment: _____ (days and dates)</p> |
| <p>Net change from previous Change Orders No. ___ to No. ___</p> <p>\$ _____</p> | <p>Net change from previous Change Orders No. ___ to No. ___</p> <p>_____</p> <p>(days)</p> |
| <p>Contract Price prior to this Change Order</p> <p>\$ _____</p> | <p>Contract Times Prior to this Change Order</p> <p>Substantial Completion: _____</p> <p>Ready for Final Payment: _____ (days and dates)</p> |
| <p>Net Increase (decrease) of this Change Order</p> <p>\$ _____</p> | <p>Net Increase (decrease) of this Change Order</p> <p>_____</p> <p>(days)</p> |
| <p>Contract Price with all approved Change Orders</p> <p>\$ _____</p> | <p>Contract Times with all approved Change Orders</p> <p>Substantial Completion: _____</p> <p>Ready for Final Payment: _____ (days and dates)</p> |

RECOMMENDED:

APPROVED:

ACCEPTED:

By: _____
Engineer/Architect (Authorized Signature)

By: _____
COUNTY (Authorized Signature)

By: _____
Contractor (Authorized Signature)

Date: _____

Date: _____

Date: _____

CHANGE ORDER**INSTRUCTIONS**

A. GENERAL INFORMATION

This document was developed to provide a uniform format for handling contract changes that affect Contract Price or Contract Times. Changes that have been initiated by a Work Change Directive must be incorporated into a subsequent Change Order if they affect Contract Price or Times.

Changes that affect Contract Price or Contract Times should be promptly covered by a Change Order. The practice of accumulating change order items to reduce the administrative burden may lead to unnecessary disputes.

If Milestones have been listed, any effect of a Change Order, thereon, should be addressed.

For supplemental instructions and minor changes not involving a change in the Contract Price or Contract Times, a Field Order may be used.

B. COMPLETING THE CHANGE ORDER FORM

Engineer / Architect / Etc. initiates the form, including a description of the changes involved and attachments based upon documents and proposals submitted by Contractor, or requests from the County or both.

Once Engineer / Architect / Etc. has completed and signed the form, all copies should be sent to Contractor for approval. After approval by Contractor, all copies should be sent to the County for approval. Engineer should make distribution of executed copies after approval by the County.

If a change only applies to Contract Price or to Contract Times, cross out the part of the tabulation that does not apply.

SECTION 00 65 16

CERTIFICATE OF SUBSTANTIAL COMPLETION

Project: _____

Purchase Order No.: _____ Contract No.: _____

This Certificate of Substantial Completion applies to:

All work under Contract Portion of work described as follows:

The Work to which this Certificate applies has been inspected by authorized representatives of the COUNTY and the CONTRACTOR and that Work is hereby declared to be substantially complete in accordance with the Contract Documents on : _____.

DATE

A tentative list of items to be completed or corrected is attached hereto. This list may not be all-inclusive, and the failure to include an item in it does not alter the responsibility of CONTRACTOR to complete all the Work in accordance with the Contract Documents. The items in the tentative list shall be completed or corrected by CONTRACTOR within _____ days of the above date of Substantial Completion.

The date of Substantial Completion is the date upon which all guarantees and warranties begin.

SIGNED:

NASSAU COUNTY PROJECT MANAGER

By: _____ DATE: _____

NASSAU COUNTY DEPARTMENT REPRESENTATIVE

By: _____ DATE: _____

ENGINEER OF RECORD:

By: _____ DATE: _____

CONTRACTOR:

By: _____ DATE: _____

SECTION 00 65 19

CERTIFICATE OF FINAL COMPLETION

Project: _____

Purchase Order No.: _____ Contract No.: _____

This Certificate of Final Completion applies to:

The Work under this Contract has been inspected by authorized representatives of the COUNTY and the CONTRACTOR and all Work is hereby declared to be complete in accordance with the Contract Documents on:

DATE

SIGNED:

NASSAU COUNTY PROJECT MANAGER

By: _____

DATE: _____

NASSAU COUNTY DEPARTMENT REPRESENTATIVE

By: _____

DATE: _____

ENGINEER OF RECORD:

By: _____

DATE: _____

CONTRACTOR:

By: _____

DATE: _____

SECTION 00 65 20

WAIVER AND RELEASE OF LIEN UPON PROGRESS PAYMENT

The undersigned lienor, in consideration of the progress payment in the amount of \$____
_____, hereby waives and releases its lien and right to claim a lien for labor, services or materials
furnished through (date)

_____ to (customer) _____
_____ on the job of (COUNTY property) _____, to the following described
property:

This waiver and release does not cover any retention of labor, services, or materials furnished after the
date specified.

Dated on _____, 20____.

Lienor's Name _____

Address _____

By _____

Printed _____

NOTE: This is a statutory form prescribed by Section 713.20, Florida Statutes.

SECTION 00 65 21

WAIVER AND RELEASE OF LIEN UPON FINAL PAYMENT

The undersigned lienor, in consideration of the final payment in the amount of \$ _____
_____, hereby waives and releases its lien and right to claim a lien for labor, services or materials
furnished through (date)

_____ to (customer) _____
on the job of (COUNTY property) _____ to the following described
property:

Dated on _____, 20____.

Lienor's Name _____

Address _____

By _____

Printed _____

NOTE: This is a statutory form prescribed by Section 713.20, Florida Statute

SECTION 00 72 15

**STANDARD GENERAL CONDITIONS
OF THE CONSTRUCTION CONTRACT**

Prepared by

ENGINEERS JOINT CONTRACT DOCUMENTS COMMITTEE

and

Issued and Published Jointly by



AMERICAN COUNCIL OF ENGINEERING COMPANIES

ASSOCIATED GENERAL BIDDERS OF AMERICA

AMERICAN SOCIETY OF CIVIL ENGINEERS

PROFESSIONAL ENGINEERS IN PRIVATE PRACTICE
A Practice Division of the
NATIONAL SOCIETY OF PROFESSIONAL ENGINEERS

Endorsed by



CONSTRUCTION SPECIFICATIONS INSTITUTE

Copyright © 2007 National Society of Professional Engineers
1420 King Street, Alexandria, VA 22314-2794
(703) 684-2882
www.nspe.org

American Council of Engineering Companies
1015 15th Street N.W., Washington, DC 20005
(202) 347-7474
www.acec.org

American Society of Civil Engineers
1801 Alexander Bell Drive, Reston, VA 20191-4400
(800) 548-2723
www.asce.org

Associated General Bidders of America
2300 Wilson Boulevard, Suite 400, Arlington, VA 22201-3308
(703) 548-3118
www.agc.org

The copyright for this EJCDC document is owned jointly by the four
EJCDC sponsoring organizations and held in trust for their benefit by NSPE.

STANDARD GENERAL CONDITIONS OF THE CONSTRUCTION CONTRACT

TABLE OF CONTENTS

| | Page |
|---|-------------|
| Article 1 – Definitions and Terminology | 1 |
| 1.01 Defined Terms..... | 1 |
| 1.02 Terminology | 5 |
| Article 2 – Preliminary Matters | 6 |
| 2.01 Delivery of Bonds and Evidence of Insurance | 6 |
| 2.02 Copies of Documents | 7 |
| 2.03 Commencement of Contract Times; Notice to Proceed..... | 7 |
| 2.04 Starting the Work | 7 |
| 2.05 Before Starting Construction | 7 |
| 2.06 Preconstruction Conference; Designation of Authorized Representatives | 7 |
| 2.07 Initial Acceptance of Schedules | 8 |
| Article 3 – Contract Documents: Intent, Amending, Reuse | 8 |
| 3.01 Intent..... | 8 |
| 3.02 Reference Standards..... | 9 |
| 3.03 Reporting and Resolving Discrepancies..... | 9 |
| 3.04 Amending and Supplementing Contract Documents..... | 10 |
| 3.05 Reuse of Documents | 10 |
| 3.06 Electronic Data..... | 11 |
| Article 4 – Availability of Lands; Subsurface and Physical Conditions; Hazardous Environmental Conditions; Reference Points..... | 11 |
| 4.01 Availability of Lands..... | 11 |
| 4.02 Subsurface and Physical Conditions..... | 12 |
| 4.03 Differing Subsurface or Physical Conditions | 12 |
| 4.04 Underground Facilities..... | 14 |
| 4.05 Reference Points..... | 15 |
| 4.06 Hazardous Environmental Condition at Site | 15 |
| Article 5 – Bonds and Insurance..... | 17 |
| 5.01 Performance, Payment, and Other Bonds..... | 17 |
| 5.02 Licensed Sureties and Insurers..... | 18 |
| 5.03 Certificates of Insurance | 18 |
| 5.04 Bidder’s Insurance..... | 19 |
| 5.05 County’s Liability Insurance | 21 |
| 5.06 Property Insurance..... | 21 |
| 5.07 Waiver of Rights | 22 |

~~5.08 Receipt and Application of Insurance Proceeds 23~~
 5.09 Acceptance of Bonds and Insurance; Option to Replace 24
~~5.10 Partial Utilization, Acknowledgment of Property Insurer..... 24~~

Article 6 – Bidder’s Responsibilities 24

6.01 Supervision and Superintendence..... 24
 6.02 Labor; Working Hours 25
 6.03 Services, Materials, and Equipment 25
 6.04 Progress Schedule 26
 6.05 Substitutes and “Or-Equals” 26
 6.06 Concerning SubContractors, Suppliers, and Others..... 29
 6.07 Patent Fees and Royalties 30
 6.08 Permits..... 31
 6.09 Laws and Regulations 31
 6.10 Taxes 32
 6.11 Use of Site and Other Areas..... 32
 6.12 Record Documents..... 33
 6.13 Safety and Protection 33
 6.14 Safety Representative..... 34
 6.15 Hazard Communication Programs..... 34
 6.16 Emergencies 34
 6.17 Shop Drawings and Samples 34
 6.18 Continuing the Work..... 36
 6.19 Bidder’s General Warranty and Guarantee..... 37
 6.20 Indemnification 37
 6.21 Delegation of Professional Design Services..... 38

Article 7 – Other Work at the Site 39

7.01 Related Work at Site 39
 7.02 Coordination..... 40
 7.03 Legal Relationships..... 40

Article 8 – County’s Responsibilities 40

8.01 Communications to Bidder 40
 8.02 Replacement of Engineer 40
 8.03 Furnish Data 40
 8.04 Pay When Due..... 41
 8.05 Lands and Easements; Reports and Tests..... 41
 8.06 Insurance..... 41
 8.07 Change Orders..... 41
 8.08 Inspections, Tests, and Approvals 41
 8.09 Limitations on County’s Responsibilities..... 41
 8.10 Undisclosed Hazardous Environmental Condition 41
 8.11 Evidence of Financial Arrangements..... 41
 8.12 Compliance with Safety Program 42

Article 9 – Engineer of Record’s Status During Construction..... 42

 9.01 County’s Representative 42

 9.02 Visits to Site 42

 9.03 Project Representative..... 42

 9.04 Authorized Variations in Work 43

 9.05 Rejecting Defective Work..... 43

 9.06 Shop Drawings, Change Orders and Payments 43

 9.07 Determinations for Unit Price Work 44

 9.08 Decisions on Requirements of Contract Documents and Acceptability of Work 44

 9.09 Limitations on Engineer of Record’s Authority and Responsibilities 44

 9.10 Compliance with Safety Program 45

Article 10 – Changes in the Work; Claims 45

 10.01 Authorized Changes in the Work 45

 10.02 Unauthorized Changes in the Work..... 45

 10.03 Execution of Change Orders..... 45

 10.04 Notification to Surety 46

 10.05 Claims..... 46

Article 11 – Cost of the Work; Allowances; Unit Price Work 47

 11.01 Cost of the Work 47

 11.02 Allowances 50

 11.03 Unit Price Work 51

Article 12 – Change of Contract Price; Change of Contract Times 51

 12.01 Change of Contract Price 51

 12.02 Change of Contract Times 52

 12.03 Delays 53

Article 13 – Tests and Inspections; Correction, Removal or Acceptance of Defective Work..... 54

 13.01 Notice of Defects..... 54

 13.02 Access to Work 54

 13.03 Tests and Inspections 54

 13.04 Uncovering Work..... 55

 13.05 County May Stop the Work 56

 13.06 Correction or Removal of Defective Work 56

 13.07 Correction Period 56

 13.08 Acceptance of Defective Work..... 57

 13.09 County May Correct Defective Work..... 58

Article 14 – Payments to Bidder and Completion..... 58

 14.01 Schedule of Values..... 58

 14.02 Progress Payments 59

 14.03 Bidder’s Warranty of Title 62

 14.04 Substantial Completion..... 62

 14.05 Partial Utilization 63

14.06 Final Inspection 63

14.07 Final Payment..... 64

14.08 Final Completion Delayed 65

14.09 Waiver of Claims 65

Article 15 – Suspension of Work and Termination 66

15.01 County May Suspend Work..... 66

15.02 County May Terminate for Cause..... 66

15.03 County May Terminate For Convenience 67

15.04 Bidder May Stop Work or Terminate..... 67

Article 16 – Dispute Resolution 68

16.01 Methods and Procedures 68

Article 17 – Miscellaneous 69

17.01 Giving Notice 69

17.02 Computation of Times 69

17.03 Cumulative Remedies 69

17.04 Survival of Obligations 69

17.05 Controlling Law 69

17.06 Headings 69

ARTICLE 1 – DEFINITIONS AND TERMINOLOGY

1.01 *Defined Terms*

- A. Wherever used in the Bidding Requirements or Contract Documents and printed with initial capital letters, the terms listed below will have the meanings indicated which are applicable to both the singular and plural thereof. In addition to terms specifically defined, terms with initial capital letters in the Contract Documents include references to identified articles and paragraphs, and the titles of other documents or forms.
1. *Addenda*—Written or graphic instruments issued prior to the opening of Bids which clarify, correct, or change the Bidding Requirements or the proposed Contract Documents.
 2. *Agreement*—The written instrument which is evidence of the agreement between County and Bidder covering the Work.
 3. *Application for Payment*—The form acceptable to Engineer of Record which is to be used by Bidder during the course of the Work in requesting progress or final payments and which is to be accompanied by such supporting documentation as is required by the Contract Documents.
 4. *Asbestos*—Any material that contains more than one percent asbestos and is friable or is releasing asbestos fibers into the air above current action levels established by the United States Occupational Safety and Health Administration.
 5. *Bid*—The offer or proposal of a Bidder submitted on the prescribed form setting forth the prices for the Work to be performed.
 6. *Bidder*—The individual or entity who submits a Bid directly to County.
 7. *Bidding Documents*—The Bidding Requirements and the proposed Contract Documents (including all Addenda).
 8. *Bidding Requirements*—The advertisement or invitation to bid, Instructions to Bidders, Bid security of acceptable form, if any, and the Bid Form with any supplements.
 9. *Change Order*—A document recommended by Engineer of Record and/or Project Manager which is signed by Bidder and County and authorizes an addition, deletion, or revision in the Work or an adjustment in the Contract Price or the Contract Times, issued on or after the Effective Date of the Agreement.
 10. *Claim*—A demand or assertion by County or Bidder seeking an adjustment of Contract Price or Contract Times, or both, or other relief with respect to the terms of the Contract. A demand for money or services by a third party is not a Claim.
 11. *Contract*—The entire and integrated written agreement between the County and Bidder concerning the Work. The Contract supersedes prior negotiations, representations, or agreements, whether written or oral.

12. *Contract Documents*—Those items so designated in the Agreement. Only printed or hard copies of the items listed in the Agreement are Contract Documents. Approved Shop Drawings, other Bidder submittals, and the reports and drawings of subsurface and physical conditions are not Contract Documents.
13. *Contract Price*—The moneys payable by County to Bidder for completion of the Work in accordance with the Contract Documents as stated in the Agreement (subject to the provisions of Paragraph 11.03 in the case of Unit Price Work).
14. *Contract Times*—The number of days or the dates stated in the Agreement to: (i) achieve Milestones, if any; (ii) achieve Substantial Completion; and (iii) complete the Work so that it is ready for final payment as evidenced by Engineer of Record and/or Project Manager's written recommendation of final payment.
15. *Cost of the Work*—See Paragraph 11.01 for definition.
16. *County*—The individual or entity with whom Bidder has entered into the Agreement and for whom the Work is to be performed.
17. *Drawings*—That part of the Contract Documents prepared or approved by Engineer of Record and/or Project Manager which graphically shows the scope, extent, and character of the Work to be performed by Bidder. Shop Drawings and other Bidder submittals are not Drawings as so defined.
18. *Effective Date of the Agreement*—The date indicated in the Agreement on which it becomes effective, but if no such date is indicated, it means the date on which the Agreement is signed and delivered by the last of the two parties to sign and deliver.
19. *Engineer of Record*—The individual or entity named as such in the Agreement.
20. *Field Order*—A written order issued by Engineer of Record and/or Project Manager which requires minor changes in the Work but which does not involve a change in the Contract Price or the Contract Times.
21. *General Requirements*—~~Sections of Division 1 of the Specifications~~ The General Requirements pertain to all Sections of the specifications. (see SC-1.01.21)
22. *Hazardous Environmental Condition*—The presence at the Site of Asbestos, PCBs, Petroleum, Hazardous Waste, or Radioactive Material in such quantities or circumstances that may present a substantial danger to persons or property exposed thereto.
23. *Hazardous Waste*—The term Hazardous Waste shall have the meaning provided in Section 1004 of the Solid Waste Disposal Act (42 USC Section 6903) as amended from time to time.

24. *Laws and Regulations; Laws or Regulations*—Any and all applicable laws, rules, regulations, ordinances, codes, and orders of any and all governmental bodies, agencies, authorities, and courts having jurisdiction.
25. *Liens*—Charges, security interests, or encumbrances upon Project funds, real property, or personal property.
26. *Milestone*—A principal event specified in the Contract Documents relating to an intermediate completion date or time prior to Substantial Completion of all the Work.
27. *Notice of Award*—The written notice by County to the Successful Bidder stating that upon timely compliance by the Successful Bidder with the conditions precedent listed therein, County will sign and deliver the Agreement.
28. *Notice to Proceed*—A written notice given by County to Bidder fixing the date on which the Contract Times will commence to run and on which Bidder shall start to perform the Work under the Contract Documents.
29. *PCBs*—Polychlorinated biphenyls.
30. *Petroleum*—Petroleum, including crude oil or any fraction thereof which is liquid at standard conditions of temperature and pressure (60 degrees Fahrenheit and 14.7 pounds per square inch absolute), such as oil, petroleum, fuel oil, oil sludge, oil refuse, gasoline, kerosene, and oil mixed with other non-Hazardous Waste and crude oils.
31. *Progress Schedule*—A schedule, prepared and maintained by Bidder, describing the sequence and duration of the activities comprising the Bidder's plan to accomplish the Work within the Contract Times.
32. *Project*—The total construction of which the Work to be performed under the Contract Documents may be the whole, or a part.
33. *Project Manager*- County employee overseeing project.
34. *Project Manual*—The bound documentary information prepared for bidding and constructing the Work. A listing of the contents of the Project Manual, which may be bound in one or more volumes, is contained in the table(s) of contents.
35. *Radioactive Material*—Source, special nuclear, or byproduct material as defined by the Atomic Energy Act of 1954 (42 USC Section 2011 et seq.) as amended from time to time.
36. *Resident Project Representative*—The authorized representative of Engineer of Record who may be assigned to the Site or any part thereof.
37. *Samples*—Physical examples of materials, equipment, or workmanship that are representative of some portion of the Work and which establish the standards by which such portion of the Work will be judged.

38. *Schedule of Submittals*—A schedule, prepared and maintained by Bidder, of required submittals and the time requirements to support scheduled performance of related construction activities.
39. *Schedule of Values*—A schedule, prepared and maintained by Bidder, allocating portions of the Contract Price to various portions of the Work and used as the basis for reviewing Bidder's Applications for Payment.
40. *Shop Drawings*—All drawings, diagrams, illustrations, schedules, and other data or information which are specifically prepared or assembled by or for Bidder and submitted by Bidder to illustrate some portion of the Work.
41. *Site*—Lands or areas indicated in the Contract Documents as being furnished by County upon which the Work is to be performed, including rights-of-way and easements for access thereto, and such other lands furnished by County which are designated for the use of Bidder.
42. *Specifications*—That part of the Contract Documents consisting of written requirements for materials, equipment, systems, standards and workmanship as applied to the Work, and certain administrative requirements and procedural matters applicable thereto.
43. *SubContractor*—An individual or entity having a direct contract with Bidder or with any other SubContractor for the performance of a part of the Work at the Site.
44. *Substantial Completion*—The time at which the Work (or a specified part thereof) has progressed to the point where, in the opinion of Engineer of Record of Record and/or Project Manager, the Work (or a specified part thereof) is sufficiently complete, in accordance with the Contract Documents, so that the Work (or a specified part thereof) can be utilized for the purposes for which it is intended. The terms "substantially complete" and "substantially completed" as applied to all or part of the Work refer to Substantial Completion thereof.
45. *Successful Bidder*—The Bidder submitting a responsive Bid to whom County makes an award.
46. *Supplementary Conditions*—That part of the Contract Documents which amends or supplements these General Conditions.
47. *Supplier*—A manufacturer, fabricator, supplier, distributor, materialman, or vendor having a direct contract with Bidder or with any SubContractor to furnish materials or equipment to be incorporated in the Work by Bidder or SubContractor.
48. *Underground Facilities*—All underground pipelines, conduits, ducts, cables, wires, manholes, vaults, tanks, tunnels, or other such facilities or attachments, and any encasements containing such facilities, including those that convey electricity, gases, steam, liquid petroleum products, telephone or other communications, cable television, water, wastewater, storm water, other liquids or chemicals, or traffic or other control systems.
49. *Unit Price Work*—Work to be paid for on the basis of unit prices.

50. *Work*—The entire construction or the various separately identifiable parts thereof required to be provided under the Contract Documents. Work includes and is the result of performing or providing all labor, services, and documentation necessary to produce such construction, and furnishing, installing, and incorporating all materials and equipment into such construction, all as required by the Contract Documents.
51. *Work Change Directive*—A written statement to Bidder issued on or after the Effective Date of the Agreement and signed by County and recommended by Engineer of Record and/or Project Manager ordering an addition, deletion, or revision in the Work, or responding to differing or unforeseen subsurface or physical conditions under which the Work is to be performed or to emergencies. A Work Change Directive will not change the Contract Price or the Contract Times but is evidence that the parties expect that the change ordered or documented by a Work Change Directive will be incorporated in a subsequently issued Change Order following negotiations by the parties as to its effect, if any, on the Contract Price or Contract Times.
52. *Surety*- The person, firm, or corporation which is bound by the contract bonds with and for Bidder (Principal); and which is held and firmly bound unto County for the conditions of obligations set forth in said bonds (see SC-1.01.52).

1.02 Terminology

- A. The words and terms discussed in Paragraph 1.02.B through F are not defined but, when used in the Bidding Requirements or Contract Documents, have the indicated meaning.
- B. *Intent of Certain Terms or Adjectives:*
 1. The Contract Documents include the terms “as allowed,” “as approved,” “as ordered,” “as directed” or terms of like effect or import to authorize an exercise of professional judgment by Engineer of Record and/or Project Manager. In addition, the adjectives “reasonable,” “suitable,” “acceptable,” “proper,” “satisfactory,” or adjectives of like effect or import are used to describe an action or determination of Engineer of Record and/or Project Manager as to the Work. It is intended that such exercise of professional judgment, action, or determination will be solely to evaluate, in general, the Work for compliance with the information in the Contract Documents and with the design concept of the Project as a functioning whole as shown or indicated in the Contract Documents (unless there is a specific statement indicating otherwise). The use of any such term or adjective is not intended to and shall not be effective to assign to Engineer of Record and/or Project Manager any duty or authority to supervise or direct the performance of the Work, or any duty or authority to undertake responsibility contrary to the provisions of Paragraph 9.09 or any other provision of the Contract Documents.
- C. *Day:*
 1. The word “day” means a calendar day of 24 hours measured from midnight to the next midnight.

D. *Defective:*

1. The word “defective,” when modifying the word “Work,” refers to Work that is unsatisfactory, faulty, or deficient in that it:
 - a. does not conform to the Contract Documents; or
 - b. does not meet the requirements of any applicable inspection, reference standard, test, or approval referred to in the Contract Documents; or
 - c. has been damaged prior to Engineer of Record and/or Project Manager’s recommendation of final payment (unless responsibility for the protection thereof has been assumed by County at Substantial Completion in accordance with Paragraph 14.04 or 14.05).

E. *Furnish, Install, Perform, Provide:*

1. The word “furnish,” when used in connection with services, materials, or equipment, shall mean to supply and deliver said services, materials, or equipment to the Site (or some other specified location) ready for use or installation and in usable or operable condition.
 2. The word “install,” when used in connection with services, materials, or equipment, shall mean to put into use or place in final position said services, materials, or equipment complete and ready for intended use.
 3. The words “perform” or “provide,” when used in connection with services, materials, or equipment, shall mean to furnish and install said services, materials, or equipment complete and ready for intended use.
 4. When “furnish,” “install,” “perform,” or “provide” is not used in connection with services, materials, or equipment in a context clearly requiring an obligation of Bidder, “provide” is implied.
- F. Unless stated otherwise in the Contract Documents, words or phrases that have a well-known technical or construction industry or trade meaning are used in the Contract Documents in accordance with such recognized meaning.

ARTICLE 2 – PRELIMINARY MATTERS

2.01 *Delivery of Bonds and Evidence of Insurance*

- A. When Bidder delivers the executed counterparts of the Agreement to County, Bidder shall also deliver to County such bonds as Bidder may be required to furnish.
- B. *Evidence of Insurance:* Before any Work at the Site is started, Bidder and County shall each deliver to the other, with copies to each additional insured identified in the Supplementary Conditions, certificates of insurance (and other evidence of insurance which either of them or any additional insured may reasonably request) which Bidder and County respectively are required to purchase and maintain in accordance with Article 5.

2.02 *Copies of Documents*

- A. County shall furnish to Bidder up to ~~ten~~ five printed or hard copies of the Drawings and Project Manual. Additional copies will be furnished upon request at the cost of reproduction. (see SC-2.02.A)

2.03 *Commencement of Contract Times; Notice to Proceed*

- A. The Contract Times will commence to run on the thirtieth day after the Effective Date of the Agreement or, if a Notice to Proceed is given, on the day indicated in the Notice to Proceed. A Notice to Proceed may be given at any time within 30 days after the Effective Date of the Agreement. In no event will the Contract Times commence to run later than the sixtieth day after the day of Bid opening or the thirtieth day after the Effective Date of the Agreement, whichever date is earlier.

2.04 *Starting the Work*

- A. Bidder shall start to perform the Work on the date when the Contract Times commence to run. No Work shall be done at the Site prior to the date on which the Contract Times commence to run.

2.05 *Before Starting Construction*

- A. Preliminary Schedules: ~~Within 10 days after the Effective Date of the Agreement~~ At the Preconstruction Conference (unless otherwise specified in the General Requirements), Bidder shall submit to Engineer of Record and/or Project Manager for timely review (see SC-2.05.A):

1. a preliminary Progress Schedule indicating the times (numbers of days or dates) for starting and completing the various stages of the Work, including any Milestones specified in the Contract Documents;
2. a preliminary Schedule of Submittals; and
3. a preliminary Schedule of Values for all of the Work which includes quantities and prices of items which when added together equal the Contract Price and subdivides the Work into component parts in sufficient detail to serve as the basis for progress payments during performance of the Work. Such prices will include an appropriate amount of overhead and profit applicable to each item of Work.

- B. Before any Work at the Site is started, Bidder shall deliver to the County, certificates of insurance that Bidder is required to purchase and maintain in accordance with Article 5. (see SC-2.05.B)

2.06 *Preconstruction Conference; Designation of Authorized Representatives*

- A. Before any Work at the Site is started, a conference attended by County, Bidder, Engineer, and others as appropriate will be held to establish a working understanding among the parties as to the Work and to discuss the schedules referred to in Paragraph 2.05.A, procedures for handling

Shop Drawings and other submittals, processing Applications for Payment, and maintaining required records.

- B. At this conference County and Bidder each shall designate, in writing, a specific individual to act as its authorized representative with respect to the services and responsibilities under the Contract. Such individuals shall have the authority to transmit instructions, receive information, render decisions relative to the Contract, and otherwise act on behalf of each respective party.
- C. County may issue Notice to Proceed at the Preconstruction Conference. Bidder shall begin the Work within twenty-four (24) hours of the date given in the Notice to Proceed. If the Bidder does not start the Work within fourteen (14) calendar days after this date, County may, at his discretion, terminate Bidder in accordance with paragraph 15.02. (see SC-2.06.C)

2.07 *Initial Acceptance of Schedules*

- A. ~~At least 10 days before submission of the first Application for Payment a conference attended by Bidder, Engineer, and others as appropriate will be held to review for acceptability to Engineer of Record as provided below the schedules submitted in accordance with Paragraph 2.05.A. Bidder shall have an additional 10 days to make corrections and adjustments and to complete and resubmit the schedules.~~ No progress payment shall be made to Bidder until acceptable schedules are submitted to Engineer of Record and/or Project Manager. All schedules as set forth in Article 2 shall be submitted and accepted by the County and Engineer of Record and/or Project Manager within 30 days of NTP. Should any schedule not be accepted within 30 days of the NTP, it will be considered a breach of contract and reason for termination of the contract for cause in accordance with the General Conditions, Section 15.02. (see SC-2.07.A)
1. The Progress Schedule will be acceptable to Engineer of Record and/or Project Manager if it provides an orderly progression of the Work to completion within the Contract Times. Such acceptance will not impose on Engineer of Record and/or Project Manager responsibility for the Progress Schedule, for sequencing, scheduling, or progress of the Work, nor interfere with or relieve Bidder from Bidder's full responsibility therefor.
 2. Bidder's Schedule of Submittals will be acceptable to Engineer of Record and/or Project Manager if it provides a workable arrangement for reviewing and processing the required submittals.
 3. Bidder's Schedule of Values will be acceptable to Engineer of Record and/or Project Manager as to form and substance if it provides a reasonable allocation of the Contract Price to component parts of the Work.

ARTICLE 3 – CONTRACT DOCUMENTS: INTENT, AMENDING, REUSE

3.01 *Intent*

- A. The Contract Documents are complementary; what is required by one is as binding as if required by all.

- B. It is the intent of the Contract Documents to describe a functionally complete project (or part thereof) to be constructed in accordance with the Contract Documents. Any labor, documentation, services, materials, or equipment that reasonably may be inferred from the Contract Documents or from prevailing custom or trade usage as being required to produce the indicated result will be provided whether or not specifically called for, at no additional cost to County.
- C. Clarifications and interpretations of the Contract Documents shall be issued by Engineer of Record as provided in Article 9.

3.02 *Reference Standards*

A. Standards, Specifications, Codes, Laws, and Regulations

1. Reference to standards, specifications, manuals, or codes of any technical society, organization, or association, or to Laws or Regulations, whether such reference be specific or by implication, shall mean the standard, specification, manual, code, or Laws or Regulations in effect at the time of opening of Bids (or on the Effective Date of the Agreement if there were no Bids), except as may be otherwise specifically stated in the Contract Documents.
2. No provision of any such standard, specification, manual, or code, or any instruction of a Supplier, shall be effective to change the duties or responsibilities of County, Bidder, or Engineer, or any of their SubContractors, consultants, agents, or employees, from those set forth in the Contract Documents. No such provision or instruction shall be effective to assign to County, Engineer, or any of their officers, directors, members, partners, employees, agents, consultants, or SubContractors, any duty or authority to supervise or direct the performance of the Work or any duty or authority to undertake responsibility inconsistent with the provisions of the Contract Documents.

3.03 *Reporting and Resolving Discrepancies*

A. *Reporting Discrepancies:*

1. *Bidder's Review of Contract Documents Before Starting Work:* Before undertaking each part of the Work, Bidder shall carefully study and compare the Contract Documents and check and verify pertinent figures therein and all applicable field measurements. Bidder shall promptly report in writing to Engineer of Record and/or Project Manager and the County any conflict, error, ambiguity, or discrepancy which Bidder discovers, or has actual knowledge of, and shall obtain a written interpretation or clarification from Engineer of Record and/or Project Manager before proceeding with any Work affected thereby.
2. *Bidder's Review of Contract Documents During Performance of Work:* If, during the performance of the Work, Bidder discovers any conflict, error, ambiguity, or discrepancy within the Contract Documents, or between the Contract Documents and (a) any applicable Law or Regulation, (b) any standard, specification, manual, or code, or (c) any instruction of any Supplier, then Bidder shall promptly report it to Engineer of Record and/or Project Manager in writing. Bidder shall not proceed with the Work affected thereby (except in an

emergency as required by Paragraph 6.16.A) until an amendment or supplement to the Contract Documents has been issued by one of the methods indicated in Paragraph 3.04.

3. Bidder shall not be liable to County or Engineer of Record and/or Project Manager for failure to report any conflict, error, ambiguity, or discrepancy in the Contract Documents unless Bidder had actual knowledge thereof.

B. Resolving Discrepancies:

1. Except as may be otherwise specifically stated in the Contract Documents, the provisions of the Contract Documents shall take precedence in resolving any conflict, error, ambiguity, or discrepancy between the provisions of the Contract Documents and:
 - a. the provisions of any standard, specification, manual, or code, or the instruction of any Supplier (whether or not specifically incorporated by reference in the Contract Documents); or
 - b. the provisions of any Laws or Regulations applicable to the performance of the Work (unless such an interpretation of the provisions of the Contract Documents would result in violation of such Law or Regulation).

3.04 Amending and Supplementing Contract Documents

- A. The Contract Documents may be amended to provide for additions, deletions, and revisions in the Work or to modify the terms and conditions thereof by either a Change Order or a Work Change Directive.
- B. The requirements of the Contract Documents may be supplemented, and minor variations and deviations in the Work may be authorized, by one or more of the following ways:
 1. A Field Order;
 2. Engineer of Record's approval of a Shop Drawing or Sample (subject to the provisions of Paragraph 6.17.D.3); or
 3. Engineer of Record's written interpretation or clarification.

3.05 Reuse of Documents

- A. Bidder and any SubContractor or Supplier shall not:
 1. have or acquire any title to or Countyship rights in any of the Drawings, Specifications, or other documents (or copies of any thereof) prepared by or bearing the seal of Engineer of Record or its consultants, including electronic media editions; or
 2. reuse any such Drawings, Specifications, other documents, or copies thereof on extensions of the Project or any other project without written consent of County and Engineer of Record specific written verification or adaptation by Engineer.

- B. The prohibitions of this Paragraph 3.05 will survive final payment, or termination of the Contract. Nothing herein shall preclude Bidder from retaining copies of the Contract Documents for record purposes.

3.06 *Electronic Data*

- A. Unless otherwise stated in the Supplementary Conditions, the data furnished by County or Engineer of Record to Bidder, or by Bidder to County or Engineer of Record or Project Manager, that may be relied upon are limited to the printed copies (also known as hard copies). Files in electronic media format of text, data, graphics, or other types are furnished only for the convenience of the receiving party. Any conclusion or information obtained or derived from such electronic files will be at the user's sole risk. If there is a discrepancy between the electronic files and the hard copies, the hard copies govern.
- B. Because data stored in electronic media format can deteriorate or be modified inadvertently or otherwise without authorization of the data's creator, the party receiving electronic files agrees that it will perform acceptance tests or procedures within 60 days, after which the receiving party shall be deemed to have accepted the data thus transferred. Any errors detected within the 60-day acceptance period will be corrected by the transferring party.
- C. When transferring documents in electronic media format, the transferring party makes no representations as to long term compatibility, usability, or readability of documents resulting from the use of software application packages, operating systems, or computer hardware differing from those used by the data's creator.

ARTICLE 4 – AVAILABILITY OF LANDS; SUBSURFACE AND PHYSICAL CONDITIONS; HAZARDOUS ENVIRONMENTAL CONDITIONS; REFERENCE POINTS

4.01 *Availability of Lands*

- A. County shall furnish the Site. County shall notify Bidder of any encumbrances or restrictions not of general application but specifically related to use of the Site with which Bidder must comply in performing the Work. County will obtain in a timely manner and pay for easements for permanent structures or permanent changes in existing facilities. If Bidder and County are unable to agree on entitlement to or on the amount or extent, if any, of any adjustment in the Contract Price or Contract Times, or both, as a result of any delay in County's furnishing the Site or a part thereof, Bidder may make a Claim therefor as provided in Paragraph 10.05.
- B. Upon reasonable written request, County shall furnish Bidder with a current statement of record legal title and legal description of the lands upon which the Work is to be performed and County's interest therein as necessary for giving notice of or filing a mechanic's or construction lien against such lands in accordance with applicable Laws and Regulations.
- C. Bidder shall provide for all additional lands and access thereto that may be required for temporary construction facilities or storage of materials and equipment. Bidder shall obtain said land rights at his own expense and without liability to the County. Bidder shall not enter upon

private property without first obtaining written permission from the rightful property County (see SC-4.01.C)

4.02 *Subsurface and Physical Conditions*

A. *Reports and Drawings:* The Supplementary Conditions identify:

1. those reports known to County of explorations and tests of subsurface conditions at or contiguous to the Site; and
2. those drawings known to County of physical conditions relating to existing surface or subsurface structures at the Site (except Underground Facilities).

B. *Limited Reliance by Bidder on Technical Data Authorized:* Bidder may rely upon the accuracy of the “technical data” contained in such reports and drawings, but such reports and drawings are not Contract Documents. Such “technical data” is identified in the Supplementary Conditions. Except for such reliance on such “technical data,” Bidder may not rely upon or make any claim against County or Engineer of Record, or any of their officers, directors, members, partners, employees, agents, consultants, or SubContractors with respect to:

1. the completeness of such reports and drawings for Bidder’s purposes, including, but not limited to, any aspects of the means, methods, techniques, sequences, and procedures of construction to be employed by Bidder, and safety precautions and programs incident thereto; or
2. other data, interpretations, opinions, and information contained in such reports or shown or indicated in such drawings; or
3. any Bidder interpretation of or conclusion drawn from any “technical data” or any such other data, interpretations, opinions, or information.

C. In the preparation of Drawings and Specifications, Engineer of Record or Engineer of Record’s Consultant relied upon the following reports(s) of explorations and tests of subsurface conditions at the site: NO GEOTECHINCAL REPORT

4.03 *Differing Subsurface or Physical Conditions*

A. *Notice:* If Bidder believes that any subsurface or physical condition that is uncovered or revealed either:

1. is of such a nature as to establish that any “technical data” on which Bidder is entitled to rely as provided in Paragraph 4.02 is materially inaccurate; or
2. is of such a nature as to require a change in the Contract Documents; or
3. differs materially from that shown or indicated in the Contract Documents; or

4. is of an unusual nature, and differs materially from conditions ordinarily encountered and generally recognized as inherent in work of the character provided for in the Contract Documents;

then Bidder shall, promptly after becoming aware thereof and before further disturbing the subsurface or physical conditions or performing any Work in connection therewith (except in an emergency as required by Paragraph 6.16.A), notify County and Engineer of Record in writing about such condition. Bidder shall not further disturb such condition or perform any Work in connection therewith (except as aforesaid) until receipt of written order to do so.

- B. *Engineer of Record's Review:* After receipt of written notice as required by Paragraph 4.03.A, Engineer of Record will promptly review the pertinent condition, determine the necessity of County's obtaining additional exploration or tests with respect thereto, and advise County in writing (with a copy to Bidder) of Engineer of Record's findings and conclusions.

C. *Possible Price and Times Adjustments:*

1. The Contract Price or the Contract Times, or both, will be equitably adjusted to the extent that the existence of such differing subsurface or physical condition causes an increase or decrease in Bidder's cost of, or time required for, performance of the Work; subject, however, to the following:
 - a. such condition must meet any one or more of the categories described in Paragraph 4.03.A; and
 - b. with respect to Work that is paid for on a unit price basis, any adjustment in Contract Price will be subject to the provisions of Paragraphs 9.07 and 11.03.
2. Bidder shall not be entitled to any adjustment in the Contract Price or Contract Times if:
 - a. Bidder knew of the existence of such conditions at the time Bidder made a final commitment to County with respect to Contract Price and Contract Times by the submission of a Bid or becoming bound under a negotiated contract; or
 - b. the existence of such condition could reasonably have been discovered or revealed as a result of any examination, investigation, exploration, test, or study of the Site and contiguous areas required by the Bidding Requirements or Contract Documents to be conducted by or for Bidder prior to Bidder's making such final commitment; or
 - c. Bidder failed to give the written notice as required by Paragraph 4.03.A.
3. If County and Bidder are unable to agree on entitlement to or on the amount or extent, if any, of any adjustment in the Contract Price or Contract Times, or both, a Claim may be made therefor as provided in Paragraph 10.05. However, ~~neither County, or Engineer, or any of their officers, directors, members, partners, employees, agents, consultants, or SubContractors~~ and Engineer of Record's Consultants shall not be liable to Bidder for any claims, costs, losses, or damages (including but not limited to all fees and charges of

engineers, architects, attorneys, and other professionals and all court ~~or arbitration~~ or other dispute resolution costs) sustained by Bidder on or in connection with any other project or anticipated project. (see SC-4.03.C.3)

4.04 *Underground Facilities*

A. *Shown or Indicated:* The information and data shown or indicated in the Contract Documents with respect to existing Underground Facilities at or contiguous to the Site is based on information and data furnished to County or Engineer of Record by the County's of such Underground Facilities, including County, or by others. Unless it is otherwise expressly provided in the Supplementary Conditions:

1. County and Engineer of Record shall not be responsible for the accuracy or completeness of any such information or data provided by others; and
2. the cost of all of the following will be included in the Contract Price, and Bidder shall have full responsibility for:
 - a. reviewing and checking all such information and data;
 - b. locating all Underground Facilities shown or indicated in the Contract Documents;
 - c. coordination of the Work with the County's of such Underground Facilities, including County, during construction; and
 - d. the safety and protection of all such Underground Facilities and repairing any damage thereto resulting from the Work.

B. *Not Shown or Indicated:*

1. If an Underground Facility is uncovered or revealed at or contiguous to the Site which was not shown or indicated, or not shown or indicated with reasonable accuracy in the Contract Documents, Bidder shall, promptly after becoming aware thereof and before further disturbing conditions affected thereby or performing any Work in connection therewith (except in an emergency as required by Paragraph 6.16.A), identify the County of such Underground Facility and give written notice to that County and to County Engineer. Engineer of Record will promptly review the Underground Facility and determine the extent, if any, to which a change is required in the Contract Documents to reflect and document the consequences of the existence or location of the Underground Facility. During such time, Bidder shall be responsible for the safety and protection of such Underground Facility.
2. If Engineer of Record concludes that a change in the Contract Documents is required, a Work Change Directive or a Change Order will be issued to reflect and document such consequences. An equitable adjustment shall be made in the Contract Price or Contract Times, or both, to the extent that they are attributable to the existence or location of any Underground Facility that was not shown or indicated or not shown or indicated with reasonable accuracy in the Contract Documents and that Bidder did not know of and could

not reasonably have been expected to be aware of or to have anticipated. If County and Bidder are unable to agree on entitlement to or on the amount or extent, if any, of any such adjustment in Contract Price or Contract Times, County or Bidder may make a Claim therefor as provided in Paragraph 10.05.

4.05 *Reference Points*

- A. County shall provide engineering surveys to establish reference points for construction which in Engineer of Record's judgment are necessary to enable Bidder to proceed with the Work. Bidder shall be responsible for laying out the Work, shall protect and preserve the established reference points and property monuments, and shall make no changes or relocations without the prior written approval of County. Bidder shall report to Engineer of Record and/or Project Manager whenever any reference point or property monument is lost or destroyed or requires relocation because of necessary changes in grades or locations, and shall be responsible for the accurate replacement or relocation of such reference points or property monuments by professionally qualified personnel.

4.06 *Hazardous Environmental Condition at Site*

- A. *Reports and Drawings:* The Supplementary Conditions identify those reports and drawings known to County relating to Hazardous Environmental Conditions that have been identified at the Site.
- B. *Limited Reliance by Bidder on Technical Data Authorized:* Bidder may rely upon the accuracy of the "technical data" contained in such reports and drawings, but such reports and drawings are not Contract Documents. Such "technical data" is identified in the Supplementary Conditions. Except for such reliance on such "technical data," Bidder may not rely upon or make any claim against County or Engineer, or any of their officers, directors, members, partners, employees, agents, consultants, or SubContractors with respect to:
1. the completeness of such reports and drawings for Bidder's purposes, including, but not limited to, any aspects of the means, methods, techniques, sequences and procedures of construction to be employed by Bidder and safety precautions and programs incident thereto; or
 2. other data, interpretations, opinions and information contained in such reports or shown or indicated in such drawings; or
 3. any Bidder interpretation of or conclusion drawn from any "technical data" or any such other data, interpretations, opinions or information.
- C. Bidder shall not be responsible for any Hazardous Environmental Condition uncovered or revealed at the Site which was not shown or indicated in Drawings or Specifications or identified in the Contract Documents to be within the scope of the Work. Bidder shall be responsible for a Hazardous Environmental Condition created with any materials brought to the Site by Bidder, SubContractors, Suppliers, or anyone else for whom Bidder is responsible.

- D. If Bidder encounters a Hazardous Environmental Condition or if Bidder or anyone for whom Bidder is responsible creates a Hazardous Environmental Condition, Bidder shall immediately: (i) secure or otherwise isolate such condition; (ii) stop all Work in connection with such condition and in any area affected thereby (except in an emergency as required by Paragraph 6.16.A); and (iii) notify County and Engineer of Record and/or Project Manager (and promptly thereafter confirm such notice in writing). County shall promptly consult with Engineer of Record concerning the necessity for County to retain a qualified expert to evaluate such condition or take corrective action, if any. Promptly after consulting with Engineer of Record, County shall take such actions as are necessary to permit County to timely obtain required permits and provide Bidder the written notice required by Paragraph 4.06.E.
- E. Bidder shall not be required to resume Work in connection with such condition or in any affected area until after County has obtained any required permits related thereto and delivered written notice to Bidder: (i) specifying that such condition and any affected area is or has been rendered safe for the resumption of Work; or (ii) specifying any special conditions under which such Work may be resumed safely. If County and Bidder cannot agree as to entitlement to or on the amount or extent, if any, of any adjustment in Contract Price or Contract Times, or both, as a result of such Work stoppage or such special conditions under which Work is agreed to be resumed by Bidder, either party may make a Claim therefor as provided in Paragraph 10.05.
- F. If after receipt of such written notice Bidder does not agree to resume such Work based on a reasonable belief it is unsafe, or does not agree to resume such Work under such special conditions, then County may order the portion of the Work that is in the area affected by such condition to be deleted from the Work. If County and Bidder cannot agree as to entitlement to or on the amount or extent, if any, of an adjustment in Contract Price or Contract Times as a result of deleting such portion of the Work, then either party may make a Claim therefor as provided in Paragraph 10.05. County may have such deleted portion of the Work performed by County's own forces or others in accordance with Article 7.
- G. To the fullest extent permitted by Laws and Regulations, County shall indemnify and hold harmless Bidder, SubContractors, and Engineer of Record, and the officers, directors, members, partners, employees, agents, consultants, and SubContractors of each and any of them from and against all claims, costs, losses, and damages (including but not limited to all fees and charges of engineers, architects, attorneys, and other professionals and all court or arbitration or other dispute resolution costs) arising out of or relating to a Hazardous Environmental Condition, provided that such Hazardous Environmental Condition: (i) was not shown or indicated in the Drawings or Specifications or identified in the Contract Documents to be included within the scope of the Work, and (ii) was not created by Bidder or by anyone for whom Bidder is responsible. Nothing in this Paragraph 4.06.G shall obligate County to indemnify any individual or entity from and against the consequences of that individual's or entity's own negligence.
- H. To the fullest extent permitted by Laws and Regulations, Bidder shall indemnify and hold harmless County and Engineer of Record, and the officers, directors, members, partners, employees, agents, consultants, and SubContractors of each and any of them from and against all claims, costs, losses, and damages (including but not limited to all fees and charges of engineers, architects, attorneys, and other professionals and all court or arbitration or other dispute

resolution costs) arising out of or relating to a Hazardous Environmental Condition created by Bidder or by anyone for whom Bidder is responsible. Nothing in this Paragraph 4.06.H shall obligate Bidder to indemnify any individual or entity from and against the consequences of that individual's or entity's own negligence.

- I. The provisions of Paragraphs 4.02, 4.03, and 4.04 do not apply to a Hazardous Environmental Condition uncovered or revealed at the Site.

ARTICLE 5 – BONDS AND INSURANCE

5.01 *Performance, Payment, and Other Bonds*

- A. Bidder shall furnish performance and payment bonds, each in an amount at least equal to the Contract Price as security for the faithful performance and payment of all of Bidder's obligations under the Contract Documents. These bonds shall remain in effect until one year after the date when final payment becomes due or until completion of the correction period specified in Paragraph 13.07, whichever is later, except as provided otherwise by Laws or Regulations or by the Contract Documents. Bidder shall also furnish such other bonds as are required by the Contract Documents.
- B. ~~All bonds shall be in the form prescribed by the Contract Documents except as provided otherwise by Laws or Regulations, and shall be executed by such sureties as are named in the list of "Companies Holding Certificates of Authority as Acceptable Sureties on Federal Bonds and as Acceptable Reinsuring Companies" as published in Circular 570 (amended) by the Financial Management Service, Surety Bond Branch, U.S. Department of the Treasury. All bonds signed by an agent or attorney in fact must be accompanied by a certified copy of that individual's authority to bind the surety. The evidence of authority shall show that it is effective on the date the agent or attorney in fact signed each bond. All Bonds shall be in the form prescribed by the contract Documents or other form approved by County. All else notwithstanding, the terms of all Bonds shall be substantially in the form prescribed by Chapter 255, Florida Statutes. All Bonds shall be executed by Bidder and a corporate bonding company licensed to transact such business in the State of Florida and named on the current list of "Surety Companies Acceptable on Federal Bonds" as published in the Treasury Department Circular Number 570. Bidder will cause the Bonds to be recorded with the Clerk of the Circuit Court in the county in which the Work is to be performed. Failure to execute bonds in the form prescribed may constitute non-responsiveness on the part of the Bidder. The expense for all Bonds shall be the Bidder's responsibility. (see SC-5.01.B)~~
- C. If the surety on any bond furnished by Bidder is declared bankrupt or becomes insolvent or its right to do business is terminated in any state where any part of the Project is located or it ceases to meet the requirements of Paragraph 5.01.B, Bidder shall promptly notify County and Engineer of Record and/or Project Manager and shall, within 20 days after the event giving rise to such notification, provide another bond and surety, both of which shall comply with the requirements of Paragraphs 5.01.B and 5.02.

5.02 *Licensed Sureties and Insurers*

- A. All bonds and insurance required by the Contract Documents to be purchased and maintained by County or Bidder shall be obtained from surety or insurance companies that are duly licensed or authorized in the jurisdiction in which the Project is located to issue bonds or insurance policies for the limits and coverages so required. Such surety and insurance companies shall also meet such additional requirements and qualifications as may be provided in the Supplementary Conditions. Certificates of insurance shall be issued by a company with a Best's rating of at least B+ authorized to do business in the State of Florida. County must approve non-rated insurers. If used, County shall be shown as Certificate Holder, Engineer of Record as Additional Insured and provide a 30-day cancellation notice.

5.03 *Certificates of Insurance*

- A. Bidder shall deliver to County, with copies to each additional insured and loss payee identified in the Supplementary Conditions, certificates of insurance (and other evidence of insurance requested by County or any other additional insured) which Bidder is required to purchase and maintain.
- B. ~~County shall deliver to Bidder, with copies to each additional insured and loss payee identified in the Supplementary Conditions, certificates of insurance (and other evidence of insurance requested by Bidder or any other additional insured) which County is required to purchase and maintain.~~ Insurance policies written on a "Claims Made" form is not acceptable without County's approval. (see SC-5.03.B)
- C. Failure of County to demand such certificates or other evidence of Bidder's full compliance with these insurance requirements or failure of County to identify a deficiency in compliance from the evidence provided shall not be construed as a waiver of Bidder's obligation to maintain such insurance.
- D. County does not represent that insurance coverage and limits established in this Contract necessarily will be adequate to protect Bidder.
- E. The insurance and insurance limits required herein shall not be deemed as a limitation on Bidder's liability under the indemnities granted to County in the Contract Documents.
- F. Umbrella Liability insurance is preferred, but an Excess Liability equivalent is acceptable. Whichever type of coverage is provided, it shall not be more restrictive than the underlying insurance policy coverages, including, but not limited to the coverage Trigger, defense, notice of occurrence/accident/circumstances, notice of claim and extended reporting period. (see SC-5.03.F)
- G. No work shall commence under this contract until the required Certificate(s) have been provided. Work shall not continue after expiration (or cancellation) until new Certificate(s) have been provided. Non-continuance of work after expiration (or cancellation) of Certificate(s) will not constitute a delay beyond Bidder's control as defined in paragraph 12.03. (see SC-5.03.G)

- H. Bidder shall arrange for its insurers' policies to include, or be endorsed to include, a severability or interest/cross liability provision, so that County will be treated as if a separate policy were in existence, but without increasing the policy limits. (see SC-5.03.H)
- I. Bidder's deductibles/self-insured retentions shall be disclosed to County and may be disapproved by the latter. They shall be reduced or eliminated at the option of County. Bidder is responsible for the amount of any deductible or self-insured retention. (see SC-6.03.I)
- J. These insurance requirements shall not relieve or limit the liability of Bidder. County does not in any way represent that these types or amounts of insurance are sufficient or adequate to protect Bidder's interests or liabilities, but are merely minimums. (see SC-5.03.J)
- K. Insurance required of Bidder or any other insurance of Bidder shall be considered primary, and insurance or self-insurance of County shall be considered excess, as may be applicable to claims that arise out of this contract. (see SC-5.03.K)
- L. Receipt of Certificates or other documentation of insurance or policies or copies of policies by County, or by any of its representatives, which indicate less coverage than required does not constitute a waiver of the Bidder's obligation to fulfill the insurance requirements herein. (see SC-5.03.L)
- M. The Bidder shall either (a) require each SubContractor to produce and maintain the same coverage as required of the Bidder, or (b) insure the activities of SubContractors in his own policy. (see SC-5.03.M)
- N. These insurance requirements are minimums and may not be adequate to cover Bidder exposures. (see SC-5.03.N)

5.04 *Bidder's Insurance*

- A. Bidder shall purchase and maintain such insurance as is appropriate for the Work being performed and as will provide protection from claims set forth below which may arise out of or result from Bidder's performance of the Work and Bidder's other obligations under the Contract Documents, whether it is to be performed by Bidder, any SubContractor or Supplier, or by anyone directly or indirectly employed by any of them to perform any of the Work, or by anyone for whose acts any of them may be liable:
 - 1. claims under workers' compensation, disability benefits, and other similar employee benefit acts;
 - 2. claims for damages because of bodily injury, occupational sickness or disease, or death of Bidder's employees;
 - 3. claims for damages because of bodily injury, sickness or disease, or death of any person other than Bidder's employees;

4. claims for damages insured by reasonably available personal injury liability coverage which are sustained:
 - a. by any person as a result of an offense directly or indirectly related to the employment of such person by Bidder, or
 - b. by any other person for any other reason;
 5. claims for damages, other than to the Work itself, because of injury to or destruction of tangible property wherever located, including loss of use resulting therefrom; and
 6. claims for damages because of bodily injury or death of any person or property damage arising out of the Countyship, maintenance or use of any motor vehicle.
- B. The policies of insurance required by this Paragraph 5.04 shall:
1. with respect to insurance required by Paragraphs 5.04.A.3 through 5.04.A.6 inclusive, be written on an occurrence basis, include as additional insureds (subject to any customary exclusion regarding professional liability) County and Engineer, and any other individuals or entities identified in the Supplementary Conditions, all of whom shall be listed as additional insureds, and include coverage for the respective officers, directors, members, partners, employees, agents, consultants, and SubContractors of each and any of all such additional insureds, and the insurance afforded to these additional insureds shall provide primary coverage for all claims covered thereby;
 2. include at least the specific coverages and be written for not less than the limits of liability provided in the Supplementary Conditions or required by Laws or Regulations, whichever is greater;
 3. include contractual liability insurance covering Bidder's indemnity obligations under Paragraphs 6.11 and 6.20;
 4. contain a provision or endorsement that the coverage afforded will not be canceled, materially changed or renewal refused until at least 30 days prior written notice has been given to County and Bidder and to each other additional insured identified in the Supplementary Conditions to whom a certificate of insurance has been issued (and the certificates of insurance furnished by the Bidder pursuant to Paragraph 5.03 will so provide);
 5. remain in effect at least until final payment and at all times thereafter when Bidder may be correcting, removing, or replacing defective Work in accordance with Paragraph 13.07; and
 6. include completed operations coverage:
 - a. Such insurance shall remain in effect for two years after final payment.
 - b. Bidder shall furnish County and each other additional insured identified in the Supplementary Conditions, to whom a certificate of insurance has been issued, evidence

satisfactory to County and any such additional insured of continuation of such insurance at final payment and one year thereafter.

- C. The limits of liability for the insurance required by paragraph 5.04 of the General Conditions shall provide coverage for not less than the amounts shown in Exhibit 1 of the contract documents, or greater where required by Laws and Regulations. (see SC-5.04.C)

5.05 *County's Liability Insurance*

- A. In addition to the insurance required to be provided by Bidder under Paragraph 5.04, County, at County's option, may purchase and maintain at County's expense County's own liability insurance as will protect County against claims which may arise from operations under the Contract Documents.

5.06 *Property Insurance*

- ~~A. Unless otherwise provided in the Supplementary Conditions, County shall purchase and maintain property insurance upon the Work at the Site in the amount of the full replacement cost thereof (subject to such deductible amounts as may be provided in the Supplementary Conditions or required by Laws and Regulations). This insurance shall:~~

- ~~1. include the interests of County, Bidder, SubContractors, and Engineer, and any other individuals or entities identified in the Supplementary Conditions, and the officers, directors, members, partners, employees, agents, consultants, and SubContractors of each and any of them, each of whom is deemed to have an insurable interest and shall be listed as a loss payee;~~
- ~~2. be written on a Builder's Risk "all risk" policy form that shall at least include insurance for physical loss or damage to the Work, temporary buildings, falsework, and materials and equipment in transit, and shall insure against at least the following perils or causes of loss: fire, lightning, extended coverage, theft, vandalism and malicious mischief, earthquake, collapse, debris removal, demolition occasioned by enforcement of Laws and Regulations, water damage (other than that caused by flood), and such other perils or causes of loss as may be specifically required by the Supplementary Conditions.~~
- ~~3. include expenses incurred in the repair or replacement of any insured property (including but not limited to fees and charges of engineers and architects);~~
- ~~4. cover materials and equipment stored at the Site or at another location that was agreed to in writing by County prior to being incorporated in the Work, provided that such materials and equipment have been included in an Application for Payment recommended by Engineer;~~
- ~~5. allow for partial utilization of the Work by County;~~
- ~~6. include testing and startup; and~~

- ~~7. be maintained in effect until final payment is made unless otherwise agreed to in writing by County, Bidder, and Engineer of Record with 30 days written notice to each other loss payee to whom a certificate of insurance has been issued.~~
- B. ~~County shall purchase and maintain such equipment breakdown insurance or additional property insurance as may be required by the Supplementary Conditions or Laws and Regulations which will include the interests of County, Bidder, SubContractors, and Engineer, and any other individuals or entities identified in the Supplementary Conditions, and the officers, directors, members, partners, employees, agents, consultants and SubContractors of each and any of them, each of whom is deemed to have an insurable interest and shall be listed as a loss payee.~~
- C. ~~All the policies of insurance (and the certificates or other evidence thereof) required to be purchased and maintained in accordance with this Paragraph 5.06 will contain a provision or endorsement that the coverage afforded will not be canceled or materially changed or renewal refused until at least 30 days prior written notice has been given to County and Bidder and to each other loss payee to whom a certificate of insurance has been issued and will contain waiver provisions in accordance with Paragraph 5.07.~~
- D. ~~County shall not be responsible for purchasing and maintaining any property insurance specified in this Paragraph 5.06 to protect the interests of Bidder, SubContractors, or others in the Work to the extent of any deductible amounts that are identified in the Supplementary Conditions. The risk of loss within such identified deductible amount will be borne by Bidder, SubContractors, or others suffering any such loss, and if any of them wishes property insurance coverage within the limits of such amounts, each may purchase and maintain it at the purchaser's own expense.~~
- E. ~~If Bidder requests in writing that other special insurance be included in the property insurance policies provided under this Paragraph 5.06, County shall, if possible, include such insurance, and the cost thereof will be charged to Bidder by appropriate Change Order. Prior to commencement of the Work at the Site, County shall in writing advise Bidder whether or not such other insurance has been procured by County.~~

~~5.07—Waiver of Rights~~

- A. ~~County and Bidder intend that all policies purchased in accordance with Paragraph 5.06 will protect County, Bidder, SubContractors, and Engineer, and all other individuals or entities identified in the Supplementary Conditions as loss payees (and the officers, directors, members, partners, employees, agents, consultants, and SubContractors of each and any of them) in such policies and will provide primary coverage for all losses and damages caused by the perils or causes of loss covered thereby. All such policies shall contain provisions to the effect that in the event of payment of any loss or damage the insurers will have no rights of recovery against any of the insureds or loss payees thereunder. County and Bidder waive all rights against each other and their respective officers, directors, members, partners, employees, agents, consultants and SubContractors of each and any of them for all losses and damages caused by, arising out of or resulting from any of the perils or causes of loss covered by such policies and any other property insurance applicable to the Work; and, in addition, waive all such rights against SubContractors and Engineer, and all other individuals or entities identified in the Supplementary Conditions as loss payees (and the officers, directors, members, partners, employees, agents, consultants, and~~

~~SubContractors of each and any of them) under such policies for losses and damages so caused. None of the above waivers shall extend to the rights that any party making such waiver may have to the proceeds of insurance held by County as trustee or otherwise payable under any policy so issued.~~

~~B. County waives all rights against Bidder, SubContractors, and Engineer, and the officers, directors, members, partners, employees, agents, consultants and SubContractors of each and any of them for:~~

- ~~1. loss due to business interruption, loss of use, or other consequential loss extending beyond direct physical loss or damage to County's property or the Work caused by, arising out of, or resulting from fire or other perils whether or not insured by County; and~~
- ~~2. loss or damage to the completed Project or part thereof caused by, arising out of, or resulting from fire or other insured peril or cause of loss covered by any property insurance maintained on the completed Project or part thereof by County during partial utilization pursuant to Paragraph 14.05, after Substantial Completion pursuant to Paragraph 14.04, or after final payment pursuant to Paragraph 14.07.~~

~~C. Any insurance policy maintained by County covering any loss, damage or consequential loss referred to in Paragraph 5.07.B shall contain provisions to the effect that in the event of payment of any such loss, damage, or consequential loss, the insurers will have no rights of recovery against Bidder, SubContractors, or Engineer, and the officers, directors, members, partners, employees, agents, consultants and SubContractors of each and any of them.~~

5.08—Receipt and Application of Insurance Proceeds

~~A. Any insured loss under the policies of insurance required by Paragraph 5.06 will be adjusted with County and made payable to County as fiduciary for the loss payees, as their interests may appear, subject to the requirements of any applicable mortgage clause and of Paragraph 5.08.B. County shall deposit in a separate account any money so received and shall distribute it in accordance with such agreement as the parties in interest may reach. If no other special agreement is reached, the damaged Work shall be repaired or replaced, the moneys so received applied on account thereof, and the Work and the cost thereof covered by an appropriate Change Order.~~

~~B. County as fiduciary shall have power to adjust and settle any loss with the insurers unless one of the parties in interest shall object in writing within 15 days after the occurrence of loss to County's exercise of this power. If such objection be made, County as fiduciary shall make settlement with the insurers in accordance with such agreement as the parties in interest may reach. If no such agreement among the parties in interest is reached, County as fiduciary shall adjust and settle the loss with the insurers and, if required in writing by any party in interest, County as fiduciary shall give bond for the proper performance of such duties.~~

5.09 *Acceptance of Bonds and Insurance; Option to Replace*

- A. ~~If either County or Bidder has any objection to the coverage afforded by or other provisions of the bonds or insurance required to be purchased and maintained by the other party in accordance with Article 5 on the basis of non-conformance with the Contract Documents, the objecting party shall so notify the other party in writing within 10 days after receipt of the certificates (or other evidence requested) required by Paragraph 2.01.B. County and Bidder shall each provide to the other such additional information in respect of insurance provided as the other may reasonably request. If either party does not purchase or maintain all of the bonds and insurance required of such party by the Contract Documents, such party shall notify the other party in writing of such failure to purchase prior to the start of the Work, or of such failure to maintain prior to any change in the required coverage. Without prejudice to any other right or remedy, the other party may elect to obtain equivalent bonds or insurance to protect such other party's interests at the expense of the party who was required to provide such coverage, and a Change Order shall be issued to adjust the Contract Price accordingly.~~ If County has any objection to the coverage afforded by or other provisions of Bonds or insurance required to be purchased and maintained by Bidder in accordance with Article 5 on the basis of non-conformance with the Contract Documents, County shall so notify Bidder in writing within ten days after receipt of the certificates (or other evidence requested) required by paragraph 2.05.C. Bidder shall provide to County such additional information in respect of insurance provided as County may reasonably request. (see SC-5.09.A)

5.10 *Partial Utilization, Acknowledgment of Property Insurer*

- A. ~~If County finds it necessary to occupy or use a portion or portions of the Work prior to Substantial Completion of all the Work as provided in Paragraph 14.05, no such use or occupancy shall commence before the insurers providing the property insurance pursuant to Paragraph 5.06 have acknowledged notice thereof and in writing effected any changes in coverage necessitated thereby. The insurers providing the property insurance shall consent by endorsement on the policy or policies, but the property insurance shall not be canceled or permitted to lapse on account of any such partial use or occupancy.~~

ARTICLE 6 – BIDDER'S RESPONSIBILITIES

6.01 *Supervision and Superintendence*

- A. Bidder shall supervise, inspect, and direct the Work competently and efficiently, devoting such attention thereto and applying such skills and expertise as may be necessary to perform the Work in accordance with the Contract Documents. Bidder shall be solely responsible for the means, methods, techniques, sequences, and procedures of construction. Bidder shall not be responsible for the negligence of County or Engineer of Record in the design or specification of a specific means, method, technique, sequence, or procedure of construction which is shown or indicated in and expressly required by the Contract Documents. County reserves the right to reject any means, methods, techniques, sequences or procedures proposed by Bidder which:
1. will constitute or create a hazard to the Work or to the persons or damage to property or existing utilities; or

2. will not produce finished work in accordance with the terms of the contract Documents.

County's failure to exercise his right to reject such means, methods, techniques, sequences or procedures shall not relieve the Bidder of his obligation to accomplish the result intended in the Contract Documents nor shall the exercise of such right create a cause of action for damages. (see SC-6.01.A)

- B. At all times during the progress of the Work, Bidder shall assign a competent resident superintendent who shall not be replaced without written notice to County and Engineer of Record except under extraordinary circumstances.

6.02 *Labor; Working Hours*

- A. Bidder shall provide competent, suitably qualified personnel to survey and lay out the Work and perform construction as required by the Contract Documents. Bidder shall at all times maintain good discipline and order at the Site.
- B. Except as otherwise required for the safety or protection of persons or the Work or property at the Site or adjacent thereto, and except as otherwise stated in the Contract Documents, all Work at the Site shall be performed during regular working hours. Bidder will not permit the performance of Work on a Saturday, Sunday, or any legal holiday without County's written consent (~~which will not be unreasonably withheld~~) given after prior written notice to Engineer of Record and/or Project Manager.
- C. Engineer of Record shall record time and costs required by Engineer of Record and Engineer of Record's Consultants to provide inspection services due to Bidder's working beyond regular working hours as defined in the General Requirements. County's reimbursement for the charges shall be a deduction from Bidder's Partial Payment(s) in accordance with Section 01 11 00 Part 2.02. (see SC-6.02.C)

6.03 *Services, Materials, and Equipment*

- A. Unless otherwise specified in the Contract Documents, Bidder shall provide and assume full responsibility for all services, materials, equipment, labor, transportation, construction equipment and machinery, tools, appliances, fuel, power, light, heat, telephone, water, sanitary facilities, temporary facilities, and all other facilities and incidentals necessary for the performance, testing, start-up, and completion of the Work.
- B. All materials and equipment incorporated into the Work shall be as specified or, if not specified, shall be of good quality and new, except as otherwise provided in the Contract Documents. All special warranties and guarantees required by the Specifications shall expressly run to the benefit of County. If required by Engineer, Bidder shall furnish satisfactory evidence (including reports of required tests) as to the source, kind, and quality of materials and equipment.
- C. All materials and equipment shall be stored, applied, installed, connected, erected, protected, used, cleaned, and conditioned in accordance with instructions of the applicable Supplier, except as otherwise may be provided in the Contract Documents.

6.04 *Progress Schedule*

- A. Bidder shall adhere to the Progress Schedule established in accordance with Paragraph 2.07 as it may be adjusted from time to time as provided below.
1. Bidder shall submit to Engineer of Record and/or Project Manager for acceptance (to the extent indicated in Paragraph 2.07) proposed adjustments in the Progress Schedule that will not result in changing the Contract Times. Such adjustments will comply with any provisions of the General Requirements applicable thereto.
 2. Proposed adjustments in the Progress Schedule that will change the Contract Times shall be submitted in accordance with the requirements of Article 12. Adjustments in Contract Times may only be made by a Change Order.

6.05 *Substitutes and "Or-Equals"*

- A. Whenever an item of material or equipment is specified or described in the Contract Documents by using the name of a proprietary item or the name of a particular Supplier, the specification or description is intended to establish the type, function, appearance, and quality required. Unless the specification or description contains or is followed by words reading that no like, equivalent, or "or-equal" item or no substitution is permitted, other items of material or equipment or material or equipment of other Suppliers may be submitted to Engineer of Record and/or Project Manager for review under the circumstances described below.
1. "*Or-Equal*" Items: If in Engineer of Record's sole discretion an item of material or equipment proposed by Bidder is functionally equal to that named and sufficiently similar so that no change in related Work will be required, it may be considered by Engineer of Record as an "or-equal" item, in which case review and approval of the proposed item may, in Engineer of Record's sole discretion, be accomplished without compliance with some or all of the requirements for approval of proposed substitute items. For the purposes of this Paragraph 6.05.A.1, a proposed item of material or equipment will be considered functionally equal to an item so named if:
 - a. in the exercise of reasonable judgment Engineer of Record determines that:
 - 1) it is at least equal in materials of construction, quality, durability, appearance, strength, and design characteristics;
 - 2) it will reliably perform at least equally well the function and achieve the results imposed by the design concept of the completed Project as a functioning whole; and
 - 3) it has a proven record of performance and availability of responsive service.
 - b. Bidder certifies that, if approved and incorporated into the Work:
 - 1) there will be no increase in cost to the County or increase in Contract Times; and

- 2) it will conform substantially to the detailed requirements of the item named in the Contract Documents.

2. *Substitute Items:*

- a. If in Engineer of Record's sole discretion an item of material or equipment proposed by Bidder does not qualify as an "or-equal" item under Paragraph 6.05.A.1, it will be considered a proposed substitute item.
- b. Bidder shall submit sufficient information as provided below to allow Engineer of Record to determine if the item of material or equipment proposed is essentially equivalent to that named and an acceptable substitute therefor. Requests for review of proposed substitute items of material or equipment will not be accepted by Engineer of Record and/or Project Manager from anyone other than Bidder.
- c. The requirements for review by Engineer of Record will be as set forth in Paragraph 6.05.A.2.d, as supplemented by the General Requirements, and as Engineer of Record may decide is appropriate under the circumstances.
- d. Bidder shall make written application to Engineer of Record and/or Project Manager for review of a proposed substitute item of material or equipment that Bidder seeks to furnish or use. The application:
 - 1) shall certify that the proposed substitute item will:
 - a) perform adequately the functions and achieve the results called for by the general design,
 - b) be similar in substance to that specified, and
 - c) be suited to the same use as that specified;
 - 2) will state:
 - a) the extent, if any, to which the use of the proposed substitute item will prejudice Bidder's achievement of Substantial Completion on time,
 - b) whether use of the proposed substitute item in the Work will require a change in any of the Contract Documents (or in the provisions of any other direct contract with County for other work on the Project) to adapt the design to the proposed substitute item, and
 - c) whether incorporation or use of the proposed substitute item in connection with the Work is subject to payment of any license fee or royalty;
 - 3) will identify:
 - a) all variations of the proposed substitute item from that specified, and

- b) available engineering, sales, maintenance, repair, and replacement services; and
- 4) shall contain an itemized estimate of all costs or credits that will result directly or indirectly from use of such substitute item, including costs of redesign and claims of other Bidders affected by any resulting change.
- e. Each action mentioned above required for review of proposed substitute items of material or equipment shall be followed in the order given. Failure to do so shall be cause for rejection of the proposed substitution. (see SC-6.05.A.2.e)
- f. Bidder shall reimburse County for the charges of Engineer of Record or Engineer of Record's Consultants for evaluation of substitutions. County's reimbursement for the charges shall be a deduction from the Bidder's Partial Payment(s). (see SC-6.05.A.2.f)
- B. *Substitute Construction Methods or Procedures:* If a specific means, method, technique, sequence, or procedure of construction is expressly required by the Contract Documents, Bidder may furnish or utilize a substitute means, method, technique, sequence, or procedure of construction approved by Engineer of Record. Bidder shall submit sufficient information to allow Engineer of Record, in Engineer of Record's sole discretion, to determine that the substitute proposed is equivalent to that expressly called for by the Contract Documents. The requirements for review by Engineer of Record will be similar to those provided in Paragraph 6.05.A.2.
- C. *Engineer of Record's Evaluation:* Engineer of Record will be allowed a reasonable time within which to evaluate each proposal or submittal made pursuant to Paragraphs 6.05.A and 6.05.B. Engineer of Record may require Bidder to furnish additional data about the proposed substitute item. Engineer of Record will be the sole judge of acceptability. No "or equal" or substitute will be ordered, installed or utilized until Engineer of Record's review is complete, which will be evidenced by a Change Order in the case of a substitute and an approved Shop Drawing for an "or equal." Engineer of Record will advise Bidder in writing of any negative determination.
- D. *Special Guarantee:* County may require Bidder to furnish at Bidder's expense a special performance guarantee or other surety with respect to any substitute.
- E. *Engineer of Record's Cost Reimbursement:* Engineer of Record will record Engineer of Record's costs in evaluating a substitute proposed or submitted by Bidder pursuant to Paragraphs 6.05.A.2 and 6.05.B. Whether or not Engineer of Record approves a substitute so proposed or submitted by Bidder, Bidder shall reimburse County for the reasonable charges of Engineer of Record for evaluating each such proposed substitute. Bidder shall also reimburse County for the reasonable charges of Engineer of Record for making changes in the Contract Documents (or in the provisions of any other direct contract with County) resulting from the acceptance of each proposed substitute.
- F. *Bidder's Expense:* Bidder shall provide all data in support of any proposed substitute or "or-equal" at Bidder's expense.

6.06 *Concerning SubContractors, Suppliers, and Others*

- A. Bidder shall not employ any SubContractor, Supplier, or other individual or entity (including those acceptable to County as indicated in Paragraph 6.06.B), whether initially or as a replacement, against whom County may have reasonable objection. Bidder shall not be required to employ any SubContractor, Supplier, or other individual or entity to furnish or perform any of the Work against whom Bidder has reasonable objection. Bidder shall not subcontract part(s) or the work, the aggregate cost of which is greater than 50 percent of the contract price, without prior written approval by County. Bidder shall cause appropriate provisions to be inserted in all subcontracts relative to the Work that bind SubContractors to Bidder by the terms of the Contract Documents insofar as applicable to the work of SubContractors and to give Bidder the same power as regards terminating any subcontract that County may exercise over Bidder under any provision of the Contract Documents. Nothing contained in the subcontract shall create any contractual relationship between SubContractor and County. Each SubContractor shall discharge all duties and responsibilities of Bidder to County covered by his subcontract. (see SC-6.06.A)
- B. If the Supplementary Conditions require the identity of certain SubContractors, Suppliers, or other individuals or entities to be submitted to County in advance for acceptance by County by a specified date prior to the Effective Date of the Agreement, and if Bidder has submitted a list thereof in accordance with the Supplementary Conditions, County's acceptance (either in writing or by failing to make written objection thereto by the date indicated for acceptance or objection in the Bidding Documents or the Contract Documents) of any such SubContractor, Supplier, or other individual or entity so identified may be revoked on the basis of reasonable objection after due investigation. Bidder shall submit an acceptable replacement for the rejected SubContractor, Supplier, or other individual or entity, and the Contract Price will be adjusted by the difference in the cost occasioned by such replacement, and an appropriate Change Order will be issued. No acceptance by County of any such SubContractor, Supplier, or other individual or entity, whether initially or as a replacement, shall constitute a waiver of any right of County or Engineer of Record to reject defective Work. SubContractors and Suppliers shall be identified on the form provided in the Bidding Requirements. (see SC-6.06.B)
- C. Bidder shall be fully responsible to County and Engineer of Record for all acts and omissions of the SubContractors, Suppliers, and other individuals or entities performing or furnishing any of the Work just as Bidder is responsible for Bidder's own acts and omissions. Nothing in the Contract Documents:
1. shall create for the benefit of any such SubContractor, Supplier, or other individual or entity any contractual relationship between County or Engineer of Record and any such SubContractor, Supplier or other individual or entity; nor
 2. shall create any obligation on the part of County or Engineer of Record to pay or to see to the payment of any moneys due any such SubContractor, Supplier, or other individual or entity except as may otherwise be required by Laws and Regulations.
- D. Bidder shall be solely responsible for scheduling and coordinating the Work of SubContractors, Suppliers, and other individuals or entities performing or furnishing any of the Work under a direct or indirect contract with Bidder.

- E. Bidder shall require all SubContractors, Suppliers, and such other individuals or entities performing or furnishing any of the Work to communicate with Engineer of Record through Bidder.
- F. The divisions and sections of the Specifications and the identifications of any Drawings shall not control Bidder in dividing the Work among SubContractors or Suppliers or delineating the Work to be performed by any specific trade.
- G. All Work performed for Bidder by a SubContractor or Supplier will be pursuant to an appropriate agreement between Bidder and the SubContractor or Supplier which specifically binds the SubContractor or Supplier to the applicable terms and conditions of the Contract Documents for the benefit of County and Engineer. Whenever any such agreement is with a SubContractor or Supplier who is listed as a loss payee on the property insurance provided in Paragraph 5.06, the agreement between the Bidder and the SubContractor or Supplier will contain provisions whereby the SubContractor or Supplier waives all rights against County, Bidder, Engineer of Record, and all other individuals or entities identified in the Supplementary Conditions to be listed as insureds or loss payees (and the officers, directors, members, partners, employees, agents, consultants, and SubContractors of each and any of them) for all losses and damages caused by, arising out of, relating to, or resulting from any of the perils or causes of loss covered by such policies and any other property insurance applicable to the Work. If the insurers on any such policies require separate waiver forms to be signed by any SubContractor or Supplier, Bidder will obtain the same.

6.07 *Patent Fees and Royalties*

- A. Bidder shall pay all license fees and royalties and assume all costs incident to the use in the performance of the Work or the incorporation in the Work of any invention, design, process, product, or device which is the subject of patent rights or copyrights held by others. If a particular invention, design, process, product, or device is specified in the Contract Documents for use in the performance of the Work and if, to the actual knowledge of County or Engineer of Record, its use is subject to patent rights or copyrights calling for the payment of any license fee or royalty to others, the existence of such rights shall be disclosed by County in the Contract Documents.
- B. To the fullest extent permitted by Laws and Regulations, County shall indemnify and hold harmless Bidder, and its officers, directors, members, partners, employees, agents, consultants, and SubContractors from and against all claims, costs, losses, and damages (including but not limited to all fees and charges of engineers, architects, attorneys, and other professionals, and all court or arbitration or other dispute resolution costs) arising out of or relating to any infringement of patent rights or copyrights incident to the use in the performance of the Work or resulting from the incorporation in the Work of any invention, design, process, product, or device specified in the Contract Documents, but not identified as being subject to payment of any license fee or royalty to others required by patent rights or copyrights.
- C. To the fullest extent permitted by Laws and Regulations, Bidder shall indemnify and hold harmless County and Engineer of Record, and the officers, directors, members, partners, employees, agents, consultants and SubContractors of each and any of them from and against all claims, costs, losses, and damages (including but not limited to all fees and charges of engineers,

architects, attorneys, and other professionals and all court or arbitration or other dispute resolution costs) arising out of or relating to any infringement of patent rights or copyrights incident to the use in the performance of the Work or resulting from the incorporation in the Work of any invention, design, process, product, or device not specified in the Contract Documents.

6.08 *Permits*

- A. Unless otherwise provided in the Supplementary Conditions, Bidder shall obtain and pay for all construction permits and licenses. County shall assist Bidder, when necessary, in obtaining such permits and licenses. Bidder shall pay all governmental charges and inspection fees necessary for the prosecution of the Work which are applicable at the time of opening of Bids, or, if there are no Bids, on the Effective Date of the Agreement. County shall pay all charges of utility County's for connections for providing permanent service to the Work. Permits, licenses, and easements for permanent structures or permanent changes in existing facilities shall be secured and paid for by County, unless otherwise specified. (see SC-6.08.A)

6.09 *Laws and Regulations*

- A. Bidder shall give all notices required by and shall comply with all Laws and Regulations applicable to the performance of the Work. Except where otherwise expressly required by applicable Laws and Regulations, neither the County, Engineer of Record and Project Manager shall be responsible for monitoring Bidder's compliance with any Laws or Regulations. Bidder shall also cause all SubContractors to comply with all federal, state, county, and municipal laws, ordinances, rules, and regulations bearing on the conduct of the Work. (see SC-6.09.A)
- B. If Bidder performs any Work knowing or having reason to know that it is contrary to Laws or Regulations, Bidder shall bear all claims, costs, losses, and damages (including but not limited to all fees and charges of engineers, architects, attorneys, and other professionals and all court or arbitration or other dispute resolution costs) arising out of or relating to such Work. However, it shall not be Bidder's responsibility to make certain that the Specifications and Drawings are in accordance with Laws and Regulations, but this shall not relieve Bidder of Bidder's obligations under Paragraph 3.03. If Bidder observes that the Contract Documents are at variance with said laws, ordinances, rates, or regulations, Bidder shall promptly notify Engineer of Record and the County in writing, and any necessary changes shall be adjusted as provided in the Contract Documents. Bidder shall not proceed with the Work until so instructed by County. (see SC-6.09.B)
- C. Changes in Laws or Regulations not known at the time of opening of Bids (or, on the Effective Date of the Agreement if there were no Bids) having an effect on the cost or time of performance of the Work shall be the subject of an adjustment in Contract Price or Contract Times. If County and Bidder are unable to agree on entitlement to or on the amount or extent, if any, of any such adjustment, a Claim may be made therefor as provided in Paragraph 10.05.

6.10 *Taxes*

- A. Bidder shall pay all sales, consumer, use, and other similar taxes required to be paid by Bidder in accordance with the Laws and Regulations of the place of the Project which are applicable during the performance of the Work.

6.11 *Use of Site and Other Areas*

A. *Limitation on Use of Site and Other Areas:*

1. Bidder shall confine construction equipment, the storage of materials and equipment, and the operations of workers to the Site and other areas permitted by Laws and Regulations, and shall not unreasonably encumber the Site and other areas with construction equipment or other materials or equipment. Bidder shall assume full responsibility for any damage to any such land or area, or to the County or occupant thereof, or of any adjacent land or areas resulting from the performance of the Work.
2. Should any claim be made by any such County or occupant because of the performance of the Work, Bidder shall promptly settle with such other party by negotiation or otherwise resolve the claim by arbitration or other dispute resolution proceeding or at law.
3. To the fullest extent permitted by Laws and Regulations, Bidder shall indemnify and hold harmless County and Engineer, and the officers, directors, members, partners, employees, agents, consultants and SubContractors of each and any of them from and against all claims, costs, losses, and damages (including but not limited to all fees and charges of engineers, architects, attorneys, and other professionals and all court or arbitration or other dispute resolution costs) arising out of or relating to any claim or action, legal or equitable, brought by any such County or occupant against County, Engineer, or any other party indemnified hereunder to the extent caused by or based upon Bidder's performance of the Work.

- B. *Removal of Debris During Performance of the Work:* During the progress of the Work Bidder shall keep the Site and other areas free from accumulations of waste materials, rubbish, and other debris. Removal and disposal of such waste materials, rubbish, and other debris shall conform to applicable Laws and Regulations.

- C. *Cleaning:* Prior to Substantial Completion of the Work Bidder shall clean the Site and the Work and make it ready for utilization by County. At the completion of the Work Bidder shall remove from the Site all tools, appliances, construction equipment and machinery, and surplus materials and shall restore to original condition all property not designated for alteration by the Contract Documents.

- D. *Loading Structures:* Bidder shall not load nor permit any part of any structure to be loaded in any manner that will endanger the structure, nor shall Bidder subject any part of the Work or adjacent property to stresses or pressures that will endanger it.

6.12 *Record Documents*

- A. Bidder shall maintain in a safe place at the Site one record copy of all Drawings, Specifications, Addenda, Change Orders, Work Change Directives, Field Orders, and written interpretations and clarifications in good order and annotated to show changes made during construction. These record documents together with all approved Samples and a counterpart of all approved Shop Drawings will be available to Engineer of Record for reference. Upon completion of the Work, these record documents, Samples, and Shop Drawings will be delivered to Engineer of Record for County. Annotations of record documents shall be legible, precise, and complete as determined by Engineer of Record and the County. (see SC-6.12.A)

6.13 *Safety and Protection*

- A. Bidder shall be solely responsible for initiating, maintaining and supervising all safety precautions and programs in connection with the Work. Such responsibility does not relieve SubContractors of their responsibility for the safety of persons or property in the performance of their work, nor for compliance with applicable safety Laws and Regulations. Bidder shall take all necessary precautions for the safety of, and shall provide the necessary protection to prevent damage, injury or loss to:
1. all persons on the Site or who may be affected by the Work;
 2. all the Work and materials and equipment to be incorporated therein, whether in storage on or off the Site; and
 3. other property at the Site or adjacent thereto, including trees, shrubs, lawns, walks, pavements, roadways, structures, utilities, and Underground Facilities not designated for removal, relocation, or replacement in the course of construction.
- B. Bidder shall comply with all applicable Laws and Regulations relating to the safety of persons or property, or to the protection of persons or property from damage, injury, or loss; and shall erect and maintain all necessary safeguards for such safety and protection. Bidder shall notify County's of adjacent property and of Underground Facilities and other utility County's when prosecution of the Work may affect them, and shall cooperate with them in the protection, removal, relocation, and replacement of their property.
- C. Bidder shall comply with the applicable requirements of County's safety programs, if any. The Supplementary Conditions identify any County's safety programs that are applicable to the Work.
- D. Bidder shall inform County and Engineer of Record and/or Project Manager of the specific requirements of Bidder's safety program with which the County's and Engineer of Record's employees and representatives must comply while at the Site.
- E. All damage, injury, or loss to any property referred to in Paragraph 6.13.A.2 or 6.13.A.3 caused, directly or indirectly, in whole or in part, by Bidder, any SubContractor, Supplier, or any other individual or entity directly or indirectly employed by any of them to perform any of the Work, or anyone for whose acts any of them may be liable, shall be remedied by Bidder (except damage or

loss attributable to the fault of Drawings or Specifications or to the acts or omissions of County or Engineer of Record or anyone employed by any of them, or anyone for whose acts any of them may be liable, and not attributable, directly or indirectly, in whole or in part, to the fault or negligence of Bidder or any SubContractor, Supplier, or other individual or entity directly or indirectly employed by any of them).

- F. Bidder's duties and responsibilities for safety and for protection of the Work shall continue until such time as all the Work is completed and Engineer of Record and/or Project Manager has issued a notice to County and Bidder in accordance with Paragraph 14.07.B that the Work is acceptable (except as otherwise expressly provided in connection with Substantial Completion).
- G. Bidder shall be responsible at all times for precautions to achieve the protection of all persons, including employees and property. Bidder shall make special effort to detect hazardous conditions and shall take prompt action where necessary to avoid accident, injury, or property damage. OSHA and all other applicable safety laws and ordinances shall be followed as well as American National Standards Institute Safety Standards. All accidents, injuries, claims, or potential claims shall be reported promptly to County. (see SC-6.13.G)

6.14 *Safety Representative*

- A. Bidder shall designate a qualified and experienced safety representative at the Site whose duties and responsibilities shall be the prevention of accidents and the maintaining and supervising of safety precautions and programs.

6.15 *Hazard Communication Programs*

- A. Bidder shall be responsible for coordinating any exchange of material safety data sheets or other hazard communication information required to be made available to or exchanged between or among employers at the Site in accordance with Laws or Regulations.

6.16 *Emergencies*

- A. In emergencies affecting the safety or protection of persons or the Work or property at the Site or adjacent thereto, Bidder is obligated to act to prevent threatened damage, injury, or loss. Bidder shall give Engineer of Record and/or Project Manager prompt written notice if Bidder believes that any significant changes in the Work or variations from the Contract Documents have been caused thereby or are required as a result thereof. If Engineer of Record determines that a change in the Contract Documents is required because of the action taken by Bidder in response to such an emergency, a Work Change Directive or Change Order will be issued.

6.17 *Shop Drawings and Samples*

- A. Bidder shall submit Shop Drawings and Samples to Engineer of Record for review and approval in accordance with the accepted Schedule of Submittals (as required by Paragraph 2.07). Each submittal will be identified as Engineer of Record may require.

1. *Shop Drawings:*
 - a. Submit number of copies specified in the General Requirements.
 - b. Data shown on the Shop Drawings will be complete with respect to quantities, dimensions, specified performance and design criteria, materials, and similar data to show Engineer of Record the services, materials, and equipment Bidder proposes to provide and to enable Engineer of Record to review the information for the limited purposes required by Paragraph 6.17.D.
 2. *Samples:*
 - a. Submit number of Samples specified in the Specifications.
 - b. Clearly identify each Sample as to material, Supplier, pertinent data such as catalog numbers, the use for which intended and other data as Engineer of Record may require to enable Engineer of Record to review the submittal for the limited purposes required by Paragraph 6.17.D.
- B. Where a Shop Drawing or Sample is required by the Contract Documents or the Schedule of Submittals, any related Work performed prior to Engineer of Record's review and approval of the pertinent submittal will be at the sole expense and responsibility of Bidder.
- C. *Submittal Procedures:*
1. Before submitting each Shop Drawing or Sample, Bidder shall have:
 - a. reviewed and coordinated each Shop Drawing or Sample with other Shop Drawings and Samples and with the requirements of the Work and the Contract Documents;
 - b. determined and verified all field measurements, quantities, dimensions, specified performance and design criteria, installation requirements, materials, catalog numbers, and similar information with respect thereto;
 - c. determined and verified the suitability of all materials offered with respect to the indicated application, fabrication, shipping, handling, storage, assembly, and installation pertaining to the performance of the Work; and
 - d. determined and verified all information relative to Bidder's responsibilities for means, methods, techniques, sequences, and procedures of construction, and safety precautions and programs incident thereto.
 2. Each submittal shall bear a stamp or specific written certification that Bidder has satisfied Bidder's obligations under the Contract Documents with respect to Bidder's review and approval of that submittal.
 3. With each submittal, Bidder shall give Engineer of Record specific written notice of any variations that the Shop Drawing or Sample may have from the requirements of the Contract

Documents. This notice shall be both a written communication separate from the Shop Drawings or Sample submittal; and, in addition, by a specific notation made on each Shop Drawing or Sample submitted to Engineer of Record for review and approval of each such variation.

D. *Engineer of Record's Review:*

1. Engineer of Record will provide timely review of Shop Drawings and Samples in accordance with the Schedule of Submittals acceptable to Engineer. Engineer of Record's review and approval will be only to determine if the items covered by the submittals will, after installation or incorporation in the Work, conform to the information given in the Contract Documents and be compatible with the design concept of the completed Project as a functioning whole as indicated by the Contract Documents.
2. Engineer of Record's review and approval will not extend to means, methods, techniques, sequences, or procedures of construction (except where a particular means, method, technique, sequence, or procedure of construction is specifically and expressly called for by the Contract Documents) or to safety precautions or programs incident thereto. The review and approval of a separate item as such will not indicate approval of the assembly in which the item functions.
3. Engineer of Record's review and approval shall not relieve Bidder from responsibility for any variation from the requirements of the Contract Documents unless Bidder has complied with the requirements of Paragraph 6.17.C.3 and Engineer of Record has given written approval of each such variation by specific written notation thereof incorporated in or accompanying the Shop Drawing or Sample. Engineer of Record's review and approval shall not relieve Bidder from responsibility for complying with the requirements of Paragraph 6.17.C.1.

E. *Resubmittal Procedures:*

1. Bidder shall make corrections required by Engineer of Record and shall return the required number of corrected copies of Shop Drawings and submit, as required, new Samples for review and approval. Bidder shall direct specific attention in writing to revisions other than the corrections called for by Engineer of Record on previous submittals.
2. Bidder shall reimburse County for the charges of the County and the County's Consultants for costs generated as a result of more than two submittals of any one Shop Drawing or Sample being required for evaluation due to rejection for noncompliance of the original submittal or lack of information required by the Contract Documents. County's reimbursement for the charges shall be a deduction from Bidder's Partial Payment(s). (see SC-6.17.E.2)

6.18 *Continuing the Work*

- A. Bidder shall carry on the Work and adhere to the Progress Schedule during all disputes or disagreements with County. No Work shall be delayed or postponed pending resolution of any

disputes or disagreements, except as permitted by Paragraph 15.04 or as County and Bidder may otherwise agree in writing.

6.19 *Bidder's General Warranty and Guarantee*

- A. Bidder warrants and guarantees to County that all Work will be in accordance with the Contract Documents and will not be defective. Engineer of Record and its officers, directors, members, partners, employees, agents, consultants, and SubContractors shall be entitled to rely on representation of Bidder's warranty and guarantee.
- B. Bidder's warranty and guarantee hereunder excludes defects or damage caused by:
1. abuse, modification, or improper maintenance or operation by persons other than Bidder, SubContractors, Suppliers, or any other individual or entity for whom Bidder is responsible;
or
 2. normal wear and tear under normal usage.
- C. Bidder's obligation to perform and complete the Work in accordance with the Contract Documents shall be absolute. None of the following will constitute an acceptance of Work that is not in accordance with the Contract Documents or a release of Bidder's obligation to perform the Work in accordance with the Contract Documents:
1. observations by Engineer of Record and/or Project Manager;
 2. recommendation by Engineer of Record or payment by County of any progress or final payment;
 3. the issuance of a certificate of Substantial Completion by Engineer of Record and/or Project Manager or any payment related thereto by County;
 4. use or occupancy of the Work or any part thereof by County;
 5. any review and approval of a Shop Drawing or Sample submittal or the issuance of a notice of acceptability by Engineer of Record;
 6. any inspection, test, or approval by others; or
 7. any correction of defective Work by County.

6.20 *Indemnification*

- A. To the fullest extent permitted by Laws and Regulations, Bidder shall indemnify and hold harmless County and Engineer, and the officers, directors, members, partners, employees, agents, consultants and SubContractors of each and any of them from and against all claims, costs, losses, and damages (including but not limited to all fees and charges of engineers, architects, attorneys, and other professionals and all court or arbitration or other dispute resolution costs) arising out of or relating to the performance of the Work, provided that any such claim, cost, loss,

or damage is attributable to bodily injury, sickness, disease, or death, or to injury to or destruction of tangible property (other than the Work itself), including the loss of use resulting therefrom but only to the extent caused by any negligent act or omission of Bidder, any SubContractor, any Supplier, or any individual or entity directly or indirectly employed by any of them to perform any of the Work or anyone for whose acts any of them may be liable. (see SC-6.20.A)

- B. In any and all claims against County or Engineer of Record or any of their officers, directors, members, partners, employees, agents, consultants, or SubContractors by any employee (or the survivor or personal representative of such employee) of Bidder, any SubContractor, any Supplier, or any individual or entity directly or indirectly employed by any of them to perform any of the Work, or anyone for whose acts any of them may be liable, the indemnification obligation under Paragraph 6.20.A shall not be limited in any way by any limitation on the amount or type of damages, compensation, or benefits payable by or for Bidder or any such SubContractor, Supplier, or other individual or entity under workers' compensation acts, disability benefit acts, or other employee benefit acts.
- C. The indemnification obligations of Bidder under Paragraph 6.20.A shall not extend to the liability of Engineer of Record and their officers, directors, members, partners, employees, agents, consultants and SubContractors arising out of:
 - 1. the preparation or approval of, or the failure to prepare or approve maps, Drawings, opinions, reports, surveys, Change Orders, designs, or Specifications; or
 - 2. giving directions or instructions, or failing to give them, if that is the primary cause of the injury or damage.
- D. Neither Bidder nor County shall sell, transfer, assign, or otherwise dispose of the contract or any portion thereof, or any right, title, or interest therein, or any obligations thereunder, without written consent of the other party. (see SC-6.20.D)

6.21 *Delegation of Professional Design Services*

- A. Bidder will not be required to provide professional design services unless such services are specifically required by the Contract Documents for a portion of the Work or unless such services are required to carry out Bidder's responsibilities for construction means, methods, techniques, sequences and procedures. Bidder shall not be required to provide professional services in violation of applicable law.
- B. If professional design services or certifications by a design professional related to systems, materials or equipment are specifically required of Bidder by the Contract Documents, County and Engineer of Record will specify all performance and design criteria that such services must satisfy. Bidder shall cause such services or certifications to be provided by a properly licensed professional, whose signature and seal shall appear on all drawings, calculations, specifications, certifications, Shop Drawings and other submittals prepared by such professional. Shop Drawings and other submittals related to the Work designed or certified by such professional, if prepared by others, shall bear such professional's written approval when submitted to Engineer.

- C. County and Engineer of Record shall be entitled to rely upon the adequacy, accuracy and completeness of the services, certifications or approvals performed by such design professionals, provided County and Engineer of Record have specified to Bidder all performance and design criteria that such services must satisfy.
- D. Pursuant to this Paragraph 6.21, Engineer of Record's review and approval of design calculations and design drawings will be only for the limited purpose of checking for conformance with performance and design criteria given and the design concept expressed in the Contract Documents. Engineer of Record's review and approval of Shop Drawings and other submittals (except design calculations and design drawings) will be only for the purpose stated in Paragraph 6.17.D.1.
- E. Bidder shall not be responsible for the adequacy of the performance or design criteria required by the Contract Documents.

ARTICLE 7 – OTHER WORK AT THE SITE

7.01 Related Work at Site

- A. County may perform other work related to the Project at the Site with County's employees, or through other direct contracts therefor, or have other work performed by a utility County. If such other work is not noted in the Contract Documents, then:
 - 1. written notice thereof will be given to Bidder prior to starting any such other work; and
 - 2. if County and Bidder are unable to agree on entitlement to or on the amount or extent, if any, of any adjustment in the Contract Price or Contract Times that should be allowed as a result of such other work, a Claim may be made therefor as provided in Paragraph 10.05.
- B. Bidder shall afford each other Bidder who is a party to such a direct contract, each utility County, and County, if County is performing other work with County's employees, proper and safe access to the Site, provide a reasonable opportunity for the introduction and storage of materials and equipment and the execution of such other work, and properly coordinate the Work with theirs. Bidder shall do all cutting, fitting, and patching of the Work that may be required to properly connect or otherwise make its several parts come together and properly integrate with such other work. Bidder shall not endanger any work of others by cutting, excavating, or otherwise altering such work; provided, however, that Bidder may cut or alter others' work with the written consent of Engineer of Record and/or Project Manager the others whose work will be affected. The duties and responsibilities of Bidder under this Paragraph are for the benefit of such utility County and other Bidders to the extent that there are comparable provisions for the benefit of Bidder in said direct contracts between County and such utility County and other Bidders.
- C. If the proper execution or results of any part of Bidder's Work depends upon work performed by others under this Article 7, Bidder shall inspect such other work and promptly report to Engineer of Record and/or Project Manager in writing any delays, defects, or deficiencies in such other work that render it unavailable or unsuitable for the proper execution and results of Bidder's Work. Bidder's failure to so report will constitute an acceptance of such other work as fit and

proper for integration with Bidder's Work except for latent defects and deficiencies in such other work.

7.02 *Coordination*

- A. If County intends to contract with others for the performance of other work on the Project at the Site, the following will be set forth in Supplementary Conditions:
1. the individual or entity who will have authority and responsibility for coordination of the activities among the various Bidders will be identified;
 2. the specific matters to be covered by such authority and responsibility will be itemized; and
 3. the extent of such authority and responsibilities will be provided.
- B. Unless otherwise provided in the Supplementary Conditions, County shall have sole authority and responsibility for such coordination.

7.03 *Legal Relationships*

- A. Paragraphs 7.01.A and 7.02 are not applicable for utilities not under the control of County.
- B. Each other direct contract of County under Paragraph 7.01.A shall provide that the other Bidder is liable to County and Bidder for the reasonable direct delay and disruption costs incurred by Bidder as a result of the other Bidder's wrongful actions or inactions.
- C. Bidder shall be liable to County and any other Bidder under direct contract to County for the reasonable direct delay and disruption costs incurred by such other Bidder as a result of Bidder's wrongful action or inactions.

ARTICLE 8 – COUNTY'S RESPONSIBILITIES

8.01 *Communications to Bidder*

- A. Except as otherwise provided in these General Conditions, County shall issue all communications to Bidder through Engineer.

8.02 *Replacement of Engineer of Record*

- A. In case of termination of the employment of Engineer of Record, County shall appoint an Engineer of Record ~~to whom Bidder makes no reasonable objection~~, whose status under the Contract Documents shall be that of the former Engineer. (see SC-8.02)

8.03 *Furnish Data*

- A. County shall promptly furnish the data required of County under the Contract Documents.

8.04 *Pay When Due*

- A. County shall make payments to Bidder when they are due as provided in Paragraphs 14.02.C and 14.07.C.

8.05 *Lands and Easements; Reports and Tests*

- A. County's duties with respect to providing lands and easements and providing engineering surveys to establish reference points are set forth in Paragraphs 4.01 and 4.05. Paragraph 4.02 refers to County's identifying and making available to Bidder copies of reports of explorations and tests of subsurface conditions and drawings of physical conditions relating to existing surface or subsurface structures at the Site.

8.06 *Insurance*

- A. County's responsibilities, if any, with respect to purchasing and maintaining liability and property insurance are set forth in Article 5.

8.07 *Change Orders*

- A. County is obligated to execute Change Orders as indicated in Paragraph 10.03.

8.08 *Inspections, Tests, and Approvals*

- A. County's responsibility with respect to certain inspections, tests, and approvals is set forth in Paragraph 13.03.B.

8.09 *Limitations on County's Responsibilities*

- A. The County shall not supervise, direct, or have control or authority over, nor be responsible for, Bidder's means, methods, techniques, sequences, or procedures of construction, or the safety precautions and programs incident thereto, or for any failure of Bidder to comply with Laws and Regulations applicable to the performance of the Work. County will not be responsible for Bidder's failure to perform the Work in accordance with the Contract Documents.

8.10 *Undisclosed Hazardous Environmental Condition*

- A. County's responsibility in respect to an undisclosed Hazardous Environmental Condition is set forth in Paragraph 4.06.

8.11 *Evidence of Financial Arrangements*

- A. Upon request of Bidder, County shall furnish Bidder reasonable evidence that financial arrangements have been made to satisfy County's obligations under the Contract Documents.

8.12 *Compliance with Safety Program*

- A. While at the Site, County's employees and representatives shall comply with the specific applicable requirements of Bidder's safety programs of which County has been informed pursuant to Paragraph 6.13.D.

ARTICLE 9 – ENGINEER OF RECORD'S STATUS DURING CONSTRUCTION

9.01 *County's Representative*

- A. Engineer of Record and/or Project Manager will be County's representative during the construction period. The duties and responsibilities and the limitations of authority of Engineer of Record and/or Project Manager as County's representative during construction are set forth in the Contract Documents.

9.02 *Visits to Site*

- A. Engineer of Record will make visits to the Site at intervals appropriate to the various stages of construction as Engineer of Record deems necessary in order to observe as an experienced and qualified design professional the progress that has been made and the quality of the various aspects of Bidder's executed Work. Based on information obtained during such visits and observations, Engineer, for the benefit of County, will determine, in general, if the Work is proceeding in accordance with the Contract Documents. Engineer of Record will not be required to make exhaustive or continuous inspections on the Site to check the quality or quantity of the Work. Engineer of Record's efforts will be directed toward providing for County a greater degree of confidence that the completed Work will conform generally to the Contract Documents. On the basis of such visits and observations, Engineer of Record and/or Project Manager will keep County informed of the progress of the Work and will endeavor to guard County against defective Work.
- B. Engineer of Record's visits and observations are subject to all the limitations on Engineer of Record's authority and responsibility set forth in Paragraph 9.09. Particularly, but without limitation, during or as a result of Engineer of Record's visits or observations of Bidder's Work, Engineer of Record will not supervise, direct, control, or have authority over or be responsible for Bidder's means, methods, techniques, sequences, or procedures of construction, or the safety precautions and programs incident thereto, or for any failure of Bidder to comply with Laws and Regulations applicable to the performance of the Work.

9.03 *Project Representative*

- A. If County and Engineer of Record agree, Engineer of Record will furnish a Resident Project Representative to assist Engineer of Record in providing more extensive observation of the Work. The authority and responsibilities of any such Resident Project Representative and assistants will be as provided in the Supplementary Conditions, and limitations on the responsibilities thereof will be as provided in Paragraph 9.09. If County designates another representative or agent to represent County at the Site who is not Engineer of Record's

consultant, agent or employee, the responsibilities and authority and limitations thereon of such other individual or entity will be as provided in the Supplementary Conditions.

9.04 *Authorized Variations in Work*

- A. Engineer of Record may authorize minor variations in the Work from the requirements of the Contract Documents which do not involve an adjustment in the Contract Price or the Contract Times and are compatible with the design concept of the completed Project as a functioning whole as indicated by the Contract Documents. These may be accomplished by a Field Order and will be binding on County and also on Bidder, who shall perform the Work involved promptly. If County or Bidder believes that a Field Order justifies an adjustment in the Contract Price or Contract Times, or both, and the parties are unable to agree on entitlement to or on the amount or extent, if any, of any such adjustment, a Claim may be made therefor as provided in Paragraph 10.05.

9.05 *Rejecting Defective Work*

- A. Engineer of Record will have authority to reject Work which Engineer of Record believes to be defective, or that Engineer of Record believes will not produce a completed Project that conforms to the Contract Documents or that will prejudice the integrity of the design concept of the completed Project as a functioning whole as indicated by the Contract Documents. Engineer of Record will also have authority to require special inspection or testing of the Work as provided in Paragraph 13.04, whether or not the Work is fabricated, installed, or completed.
- B. Bidder shall reimburse the County for the charges of Engineer of Record and Engineer of Records's Consultants for any additional field observations, engineering analysis, correspondence, meetings, or other work due to non-complying or defective construction, materials, or equipment performed or furnished by the Bidder, SubContractors, or Suppliers. County's reimbursement for the charges shall be a deduction from the Bidder's Partial Payment(s). (see SC-9.05.B)

9.06 *Shop Drawings, Change Orders and Payments*

- A. In connection with Engineer of Record's authority, and limitations thereof, as to Shop Drawings and Samples, see Paragraph 6.17.
- B. In connection with Engineer of Record's authority, and limitations thereof, as to design calculations and design drawings submitted in response to a delegation of professional design services, if any, see Paragraph 6.21.
- C. In connection with Engineer of Record's authority as to Change Orders, see Articles 10, 11, and 12.
- D. In connection with Engineer of Record's authority as to Applications for Payment, see Article 14.

9.07 *Determinations for Unit Price Work*

- A. Engineer of Record will determine the actual quantities and classifications of Unit Price Work performed by Bidder. Engineer of Record will review with Bidder the Engineer of Record's preliminary determinations on such matters before rendering a written decision thereon (by recommendation of an Application for Payment or otherwise). Engineer of Record's written decision thereon will be final and binding (except as modified by Engineer of Record to reflect changed factual conditions or more accurate data) upon County and Bidder, subject to the provisions of Paragraph 10.05.

9.08 *Decisions on Requirements of Contract Documents and Acceptability of Work*

- A. Engineer of Record and/or Project Manager will be the initial interpreter of the requirements of the Contract Documents and judge of the acceptability of the Work thereunder. All matters in question and other matters between County and Bidder arising prior to the date final payment is due relating to the acceptability of the Work, and the interpretation of the requirements of the Contract Documents pertaining to the performance of the Work, will be referred initially to Engineer of Record and/or Project Manager in writing within 30 days of the event giving rise to the question.
- B. Engineer of Record will, with reasonable promptness, render a written decision on the issue referred. If County or Bidder believes that any such decision entitles them to an adjustment in the Contract Price or Contract Times or both, a Claim may be made under Paragraph 10.05. The date of Engineer of Record's decision shall be the date of the event giving rise to the issues referenced for the purposes of Paragraph 10.05.B.
- C. Engineer of Record's written decision on the issue referred will be final and binding on County and Bidder, subject to the provisions of Paragraph 10.05.
- D. When functioning as interpreter and judge under this Paragraph 9.08, Engineer of Record will not show partiality to County or Bidder and will not be liable in connection with any interpretation or decision rendered in good faith in such capacity.

9.09 *Limitations on Engineer of Record's Authority and Responsibilities*

- A. Neither Engineer of Record's authority or responsibility under this Article 9 or under any other provision of the Contract Documents nor any decision made by Engineer of Record in good faith either to exercise or not exercise such authority or responsibility or the undertaking, exercise, or performance of any authority or responsibility by Engineer of Record shall create, impose, or give rise to any duty in contract, tort, or otherwise owed by Engineer of Record to Bidder, any SubContractor, any Supplier, any other individual or entity, or to any surety for or employee or agent of any of them.
- B. Engineer of Record will not supervise, direct, control, or have authority over or be responsible for Bidder's means, methods, techniques, sequences, or procedures of construction, or the safety precautions and programs incident thereto, or for any failure of Bidder to comply with Laws and

Regulations applicable to the performance of the Work. Engineer of Record will not be responsible for Bidder's failure to perform the Work in accordance with the Contract Documents.

- C. Engineer of Record will not be responsible for the acts or omissions of Bidder or of any SubContractor, any Supplier, or of any other individual or entity performing any of the Work.
- D. Engineer of Record's review of the final Application for Payment and accompanying documentation and all maintenance and operating instructions, schedules, guarantees, bonds, certificates of inspection, tests and approvals, and other documentation required to be delivered by Paragraph 14.07.A will only be to determine generally that their content complies with the requirements of, and in the case of certificates of inspections, tests, and approvals that the results certified indicate compliance with, the Contract Documents.
- E. The limitations upon authority and responsibility set forth in this Paragraph 9.09 shall also apply to the Project Manager, if any, and assistants, if any.

9.10 *Compliance with Safety Program*

- A. While at the Site, Engineer of Record's employees and representatives shall comply with the specific applicable requirements of Bidder's safety programs of which Engineer of Record has been informed pursuant to Paragraph 6.13.D.

ARTICLE 10 – CHANGES IN THE WORK; CLAIMS

10.01 *Authorized Changes in the Work*

- A. Without invalidating the Contract and without notice to any surety, County may, at any time or from time to time, order additions, deletions, or revisions in the Work by a Change Order, or a Work Change Directive. Upon receipt of any such document, Bidder shall promptly proceed with the Work involved which will be performed under the applicable conditions of the Contract Documents (except as otherwise specifically provided).
- B. If County and Bidder are unable to agree on entitlement to, or on the amount or extent, if any, of an adjustment in the Contract Price or Contract Times, or both, that should be allowed as a result of a Work Change Directive, a Claim may be made therefor as provided in Paragraph 10.05.

10.02 *Unauthorized Changes in the Work*

- A. Bidder shall not be entitled to an increase in the Contract Price or an extension of the Contract Times with respect to any work performed that is not required by the Contract Documents as amended, modified, or supplemented as provided in Paragraph 3.04, except in the case of an emergency as provided in Paragraph 6.16 or in the case of uncovering Work as provided in Paragraph 13.04.D.

10.03 *Execution of Change Orders*

- A. County and Bidder shall execute appropriate Change Orders recommended by Engineer of Record and/or Project Manager covering:

1. changes in the Work which are: (i) ordered by County pursuant to Paragraph 10.01.A, (ii) required because of acceptance of defective Work under Paragraph 13.08.A or County's correction of defective Work under Paragraph 13.09, or (iii) agreed to by the parties;
2. changes in the Contract Price or Contract Times which are agreed to by the parties, including any undisputed sum or amount of time for Work actually performed in accordance with a Work Change Directive; and
3. changes in the Contract Price or Contract Times which embody the substance of any written decision rendered by Engineer of Record pursuant to Paragraph 10.05; provided that, in lieu of executing any such Change Order, an appeal may be taken from any such decision in accordance with the provisions of the Contract Documents and applicable Laws and Regulations, but during any such appeal, Bidder shall carry on the Work and adhere to the Progress Schedule as provided in Paragraph 6.18.A.

10.04 *Notification to Surety*

- A. If the provisions of any bond require notice to be given to a surety of any change affecting the general scope of the Work or the provisions of the Contract Documents (including, but not limited to, Contract Price or Contract Times), the giving of any such notice will be Bidder's responsibility. The amount of each applicable bond will be adjusted to reflect the effect of any such change.

10.05 *Claims*

- A. *Engineer of Record's Decision Required:* All Claims, except those waived pursuant to Paragraph 14.09, shall be referred to the Engineer of Record for decision. A decision by Engineer of Record shall be required as a condition precedent to any exercise by County or Bidder of any rights or remedies either may otherwise have under the Contract Documents or by Laws and Regulations in respect of such Claims.
- B. *Notice:* Written notice stating the general nature of each Claim shall be delivered by the claimant to Engineer of Record to the other party to the Contract promptly (but in no event later than ~~30~~ 15 days) after the start of the event giving rise thereto. The responsibility to substantiate a Claim shall rest with the party making the Claim. Notice of the amount or extent of the Claim, with supporting data shall be delivered to the Engineer of Record and the other party to the Contract within 60 days after the start of such event (unless Engineer of Record allows additional time for claimant to submit additional or more accurate data in support of such Claim). A Claim for an adjustment in Contract Price shall be prepared in accordance with the provisions of Paragraph 12.01.B. A Claim for an adjustment in Contract Times shall be prepared in accordance with the provisions of Paragraph 12.02.B. Each Claim shall be accompanied by claimant's written statement that the adjustment claimed is the entire adjustment to which the claimant believes it is entitled as a result of said event. The opposing party shall submit any response to Engineer of Record and the claimant within 30 days after receipt of the claimant's last submittal (unless Engineer of Record allows additional time). (see SC-10.05.B)

- C. *Engineer of Record's Action:* Engineer of Record will review each Claim and, within 30 days after receipt of the last submittal of the claimant or the last submittal of the opposing party, if any, take one of the following actions in writing:
1. deny the Claim in whole or in part;
 2. approve the Claim; or
 3. notify the parties that the Engineer of Record is unable to resolve the Claim if, in the Engineer of Record's sole discretion, it would be inappropriate for the Engineer of Record to do so. For purposes of further resolution of the Claim, such notice shall be deemed a denial.
- D. In the event that Engineer of Record does not take action on a Claim within said 30 days, the Claim shall be deemed denied.
- E. Engineer of Record's written action under Paragraph 10.05.C or denial pursuant to Paragraphs 10.05.C.3 or 10.05.D will be final and binding upon County and Bidder, unless County or Bidder invoke the dispute resolution procedure set forth in Article 16 within 30 days of such action or denial.
- F. No Claim for an adjustment in Contract Price or Contract Times will be valid if not submitted in accordance with this Paragraph 10.05.

ARTICLE 11 – COST OF THE WORK; ALLOWANCES; UNIT PRICE WORK

11.01 Cost of the Work

- A. *Costs Included:* The term Cost of the Work means the sum of all costs, except those excluded in Paragraph 11.01.B, necessarily incurred and paid by Bidder in the proper performance of the Work. When the value of any Work covered by a Change Order or when a Claim for an adjustment in Contract Price is determined on the basis of Cost of the Work, the costs to be reimbursed to Bidder will be only those additional or incremental costs required because of the change in the Work or because of the event giving rise to the Claim. Except as otherwise may be agreed to in writing by County, such costs shall be in amounts no higher than those prevailing in the locality of the Project, shall not include any of the costs itemized in Paragraph 11.01.B, and shall include only the following items:
1. Payroll costs for employees in the direct employ of Bidder in the performance of the Work under schedules of job classifications agreed upon by County and Bidder. Such employees shall include, without limitation, superintendents, foremen, and other personnel employed full time on the Work. Payroll costs for employees not employed full time on the Work shall be apportioned on the basis of their time spent on the Work. Payroll costs shall include, but not be limited to, salaries and wages plus the cost of fringe benefits, which shall include social security contributions, unemployment, excise, and payroll taxes, workers' compensation, health and retirement benefits, bonuses, sick leave, vacation and holiday pay applicable thereto. The expenses of performing Work outside of regular working hours, on

Saturday, Sunday, or legal holidays, shall be included in the above to the extent authorized by County.

2. Cost of all materials and equipment furnished and incorporated in the Work, including costs of transportation and storage thereof, and Suppliers' field services required in connection therewith. All cash discounts shall accrue to Bidder unless County deposits funds with Bidder with which to make payments, in which case the cash discounts shall accrue to County. All trade discounts, rebates and refunds and returns from sale of surplus materials and equipment shall accrue to County, and Bidder shall make provisions so that they may be obtained.
3. Payments made by Bidder to SubContractors for Work performed by SubContractors. If required by County, Bidder shall obtain competitive bids from SubContractors acceptable to County and Bidder and shall deliver such bids to County, who will then determine, with the advice of Engineer of Record, which bids, if any, will be acceptable. If any subcontract provides that the SubContractor is to be paid on the basis of Cost of the Work plus a fee, the SubContractor's Cost of the Work and fee shall be determined in the same manner as Bidder's Cost of the Work and fee as provided in this Paragraph 11.01.
4. Costs of special consultants (including but not limited to engineers, architects, testing laboratories, surveyors, attorneys, and accountants) employed for services specifically related to the Work.
5. Supplemental costs including the following:
 - a. The proportion of necessary transportation, travel, and subsistence expenses of Bidder's employees incurred in discharge of duties connected with the Work.
 - b. Cost, including transportation and maintenance, of all materials, supplies, equipment, machinery, appliances, office, and temporary facilities at the Site, and hand tools not owned by the workers, which are consumed in the performance of the Work, and cost, less market value, of such items used but not consumed which remain the property of Bidder.
 - c. Rentals of all construction equipment and machinery, and the parts thereof whether rented from Bidder or others in accordance with rental agreements approved by County with the advice of the Engineer of Record/and/or Project Manager, and the costs of transportation, loading, unloading, assembly, dismantling, and removal thereof. All such costs shall be in accordance with the terms of said rental agreements. The rental of any such equipment, machinery, or parts shall cease when the use thereof is no longer necessary for the Work. In no case shall rates exceed those published by the current edition of Data Quest Incorporated titled, Rental Rate Blue Book for Construction Equipment, and other procedures established by Florida Department of Transportation. (see SC-11.01.A.5.c)
 - d. Sales, consumer, use, and other similar taxes related to the Work, and for which Bidder is liable, as imposed by Laws and Regulations.

- e. Deposits lost for causes other than negligence of Bidder, any SubContractor, or anyone directly or indirectly employed by any of them or for whose acts any of them may be liable, and royalty payments and fees for permits and licenses.
- f. Losses and damages (and related expenses) caused by damage to the Work, not compensated by insurance or otherwise, sustained by Bidder in connection with the performance of the Work (~~except losses and damages within the deductible amounts of property insurance established in accordance with Paragraph 5.06.D~~), provided such losses and damages have resulted from causes other than the negligence of Bidder, any SubContractor, or anyone directly or indirectly employed by any of them or for whose acts any of them may be liable. Such losses shall include settlements made with the written consent and approval of County. No such losses, damages, and expenses shall be included in the Cost of the Work for the purpose of determining Bidder's fee. (see SC-11.01.A.5.f)
- g. The cost of utilities, fuel, and sanitary facilities at the Site.
- h. Minor expenses such as telegrams, long distance telephone calls, telephone service at the Site, express and courier services, and similar petty cash items in connection with the Work.
- i. The costs of premiums for all bonds and insurance Bidder is required by the Contract Documents to purchase and maintain.
- j. The cost of specific consideration for the indemnifications set forth in paragraph 6.20. (see SC-11.01.A.5.j)
- k. The cost of compliance with current local, state and federal safety regulations. (see SC-11.01.A.5.k)

B. *Costs Excluded:* The term Cost of the Work shall not include any of the following items:

1. Payroll costs and other compensation of Bidder's officers, executives, principals (of partnerships and sole proprietorships), general managers, safety managers, engineers, architects, estimators, attorneys, auditors, accountants, purchasing and contracting agents, expeditors, timekeepers, clerks, and other personnel employed by Bidder, whether at the Site or in Bidder's principal or branch office for general administration of the Work and not specifically included in the agreed upon schedule of job classifications referred to in Paragraph 11.01.A.1 or specifically covered by Paragraph 11.01.A.4, all of which are to be considered administrative costs covered by the Bidder's fee.
2. Expenses of Bidder's principal and branch offices other than Bidder's office at the Site.
3. Any part of Bidder's capital expenses, including interest on Bidder's capital employed for the Work and charges against Bidder for delinquent payments.

4. Costs due to the negligence of Bidder, any SubContractor, or anyone directly or indirectly employed by any of them or for whose acts any of them may be liable, including but not limited to, the correction of defective Work, disposal of materials or equipment wrongly supplied, and making good any damage to property.
 5. Other overhead or general expense costs of any kind and the costs of any item not specifically and expressly included in Paragraphs 11.01.A.
- C. *Bidder's Fee:* When all the Work is performed on the basis of cost-plus, Bidder's fee shall be determined as set forth in the Agreement. When the value of any Work covered by a Change Order or when a Claim for an adjustment in Contract Price is determined on the basis of Cost of the Work, Bidder's fee shall be determined as set forth in Paragraph 12.01.C.
- D. *Documentation:* Whenever the Cost of the Work for any purpose is to be determined pursuant to Paragraphs 11.01.A and 11.01.B, Bidder will establish and maintain records thereof in accordance with generally accepted accounting practices and submit in a form acceptable to Engineer of Record an itemized cost breakdown together with supporting data.

11.02 Allowances

- A. It is understood that Bidder has included in the Contract Price all allowances so named in the Contract Documents and shall cause the Work so covered to be performed for such sums and by such persons or entities as may be acceptable to County and Engineer.
- B. *Cash Allowances:*
1. Bidder agrees that:
 - a. the cash allowances include the cost to Bidder (less any applicable trade discounts) of materials and equipment required by the allowances to be delivered at the Site, and all applicable taxes; and
 - b. Bidder's costs for unloading and handling on the Site, labor, installation, overhead, profit, and other expenses contemplated for the cash allowances have been included in the Contract Price and not in the allowances, and no demand for additional payment on account of any of the foregoing will be valid.
- C. *Contingency Allowance:*
1. Bidder agrees that a contingency allowance, if any, is for the sole use of County to cover unanticipated costs.
- D. Prior to final payment, an appropriate Change Order will be issued as recommended by Engineer of Record and/or Project Manager to reflect actual amounts due Bidder on account of Work covered by allowances, and the Contract Price shall be correspondingly adjusted.

11.03 *Unit Price Work*

- A. Where the Contract Documents provide that all or part of the Work is to be Unit Price Work, initially the Contract Price will be deemed to include for all Unit Price Work an amount equal to the sum of the unit price for each separately identified item of Unit Price Work times the estimated quantity of each item as indicated in the Agreement.
- B. The estimated quantities of items of Unit Price Work are not guaranteed and are solely for the purpose of comparison of Bids and determining an initial Contract Price. Determinations of the actual quantities and classifications of Unit Price Work performed by Bidder will be made by Engineer of Record subject to the provisions of Paragraph 9.07.
- C. Each unit price will be deemed to include an amount considered by Bidder to be adequate to cover Bidder's overhead and profit for each separately identified item.
- D. County or Bidder may make a Claim for an adjustment in the Contract Price in accordance with Paragraph 10.05 if:
 - 1. the quantity of any item of Unit Price Work performed by Bidder differs materially and significantly from the estimated quantity of such item indicated in the Agreement; and
 - 2. there is no corresponding adjustment with respect to any other item of Work; and
 - 3. Bidder believes that Bidder is entitled to an increase in Contract Price as a result of having incurred additional expense or County believes that County is entitled to a decrease in Contract Price and the parties are unable to agree as to the amount of any such increase or decrease.
- E. If County objects to Bidder's quoted adjustment in Unit Price Work set forth in paragraph 11.03.D, County may assign such work to its own forces or another Bidder.
- F. County reserves the right to delete any Unit Price Work without financial penalty incurred from Bidder.

ARTICLE 12 – CHANGE OF CONTRACT PRICE; CHANGE OF CONTRACT TIMES

12.01 *Change of Contract Price*

- A. The Contract Price may only be changed by a Change Order. Any Claim for an adjustment in the Contract Price shall be based on written notice submitted by the party making the Claim to the Engineer of Record and/or Project Manager and the other party to the Contract in accordance with the provisions of Paragraph 10.05.
- B. The value of any Work covered by a Change Order or of any Claim for an adjustment in the Contract Price will be determined as follows:

1. where the Work involved is covered by unit prices contained in the Contract Documents, by application of such unit prices to the quantities of the items involved (subject to the provisions of Paragraph 11.03); or
2. where the Work involved is not covered by unit prices contained in the Contract Documents, by a mutually agreed lump sum (which may include an allowance for overhead and profit not necessarily in accordance with Paragraph 12.01.C.2); or
3. where the Work involved is not covered by unit prices contained in the Contract Documents and agreement to a lump sum is not reached under Paragraph 12.01.B.2, on the basis of the Cost of the Work (determined as provided in Paragraph 11.01) plus a Bidder's fee for overhead and profit (determined as provided in Paragraph 12.01.C).

C. *Bidder's Fee*: The Bidder's fee for overhead and profit shall be determined as follows:

1. a mutually acceptable fixed fee; or
2. if a fixed fee is not agreed upon, then a fee based on the following percentages of the various portions of the Cost of the Work:
 - a. for costs incurred under Paragraphs 11.01.A.1 and 11.01.A.2, the Bidder's fee shall be 15 percent;
 - b. for costs incurred under Paragraph 11.01.A.3, the Bidder's fee shall be five percent;
 - c. where one or more tiers of subcontracts are on the basis of Cost of the Work plus a fee and no fixed fee is agreed upon, the intent of Paragraphs 12.01.C.2.a and 12.01.C.2.b is that the SubContractor who actually performs the Work, at whatever tier, will be paid a fee of 15 percent of the costs incurred by such SubContractor under Paragraphs 11.01.A.1 and 11.01.A.2 and that any higher tier SubContractor and Bidder will each be paid a fee of five percent of the amount paid to the next lower tier SubContractor;
 - d. no fee shall be payable on the basis of costs itemized under Paragraphs 11.01.A.4, 11.01.A.5, and 11.01.B;
 - e. the amount of credit to be allowed by Bidder to County for any change which results in a net decrease in cost will be the amount of the actual net decrease in cost plus a deduction in Bidder's fee by an amount equal to five percent of such net decrease; and
 - f. when both additions and credits are involved in any one change, the adjustment in Bidder's fee shall be computed on the basis of the net change in accordance with Paragraphs 12.01.C.2.a through 12.01.C.2.e, inclusive.

12.02 *Change of Contract Times*

- A. The Contract Times may only be changed by a Change Order. Any Claim for an adjustment in the Contract Times shall be based on written notice submitted by the party making the Claim to

the Engineer of Record and/or Project Manager and the other party to the Contract in accordance with the provisions of Paragraph 10.05.

- B. Any adjustment of the Contract Times covered by a Change Order or any Claim for an adjustment in the Contract Times will be determined in accordance with the provisions of this Article 12.
- C. On the 21st of each month, or the next following business day, the Bidder shall submit to the County and Engineer of Record a request for weather days. Failure to submit the request forfeits the right to claim weather days for that period and any previous period. The County will grant time extensions, on a day for day basis, for delays caused by the effects of rains or other inclement weather conditions or related adverse soil conditions that prevent the Bidder from productively performing controlling items of work resulting in:
- (1) The Bidder being unable to work at least 50% of the normal work day on pre-determined controlling work items due to adverse weather conditions.

No additional compensation will be made for delays caused by the effects of inclement weather. (see SC-12.02.C)

12.03 *Delays*

- A. Where Bidder is prevented from completing any part of the Work within the Contract Times due to delay beyond the control of Bidder, the Contract Times will be extended in an amount equal to the time lost due to such delay if a Claim is made therefor as provided in Paragraph 12.02.A. Delays beyond the control of Bidder shall include, but not be limited to, acts or neglect by County, acts or neglect of utility Countys or other Bidders performing other work as contemplated by Article 7, fires, floods, epidemics, abnormal weather conditions, or acts of God.
- B. If County, Engineer of Record, or other Bidders or utility County performing other work for County as contemplated by Article 7, or anyone for whom County is responsible, delays, disrupts, or interferes with the performance or progress of the Work, then Bidder shall be entitled to an equitable adjustment in the Contract Price or the Contract Times, or both. Bidder's entitlement to an adjustment of the Contract Times is conditioned on such adjustment being essential to Bidder's ability to complete the Work within the Contract Times.
- C. If Bidder is delayed in the performance or progress of the Work by fire, flood, epidemic, abnormal weather conditions, acts of God, acts or failures to act of utility County not under the control of County, or other causes not the fault of and beyond control of County and Bidder, then Bidder shall be entitled to an equitable adjustment in Contract Times, if such adjustment is essential to Bidder's ability to complete the Work within the Contract Times. Such an adjustment shall be Bidder's sole and exclusive remedy for the delays described in this Paragraph 12.03.C.
- D. County, Engineer, and their officers, directors, members, partners, employees, agents, consultants, or SubContractors shall not be liable to Bidder for any claims, costs, losses, or damages (including but not limited to all fees and charges of engineers, architects, attorneys, and

other professionals and all court or arbitration or other dispute resolution costs) sustained by Bidder on or in connection with any other project or anticipated project.

- E. Bidder shall not be entitled to an adjustment in Contract Price or Contract Times for delays within the control of Bidder. Delays attributable to and within the control of a SubContractor or Supplier shall be deemed to be delays within the control of Bidder.

ARTICLE 13 – TESTS AND INSPECTIONS; CORRECTION, REMOVAL OR ACCEPTANCE OF DEFECTIVE WORK

13.01 *Notice of Defects*

- A. Prompt notice of all defective Work of which County or Engineer of Record and/or Project Manager has actual knowledge will be given to Bidder. Defective Work may be rejected, corrected, or accepted as provided in this Article 13.

13.02 *Access to Work*

- A. County, Engineer of Record, their consultants and other representatives and personnel of County, independent testing laboratories, and governmental agencies with jurisdictional interests will have access to the Site and the Work at reasonable times for their observation, inspection, and testing. Bidder shall provide them proper and safe conditions for such access and advise them of Bidder's safety procedures and programs so that they may comply therewith as applicable.

13.03 *Tests and Inspections*

- A. Bidder shall give Engineer of Record and/or Project Manager timely notice of readiness of the Work for all required inspections, tests, or approvals and shall cooperate with inspection and testing personnel to facilitate required inspections or tests. Bidder shall reimburse County for the charges of Engineer of Record and Engineer of Record's Consultants for all costs due to work not being ready for tests and/or inspections when the Bidder has notified Engineer of Record that work is ready for tests and/or inspections. Bidder shall reimburse County for all failed tests and subsequent retests. Reimbursement for the charges shall be a deduction from the Bidder's Partial Payment(s). (see SC-13.03.A)
- ~~B. County shall employ and pay for the services of an independent testing laboratory to perform all inspections, tests, or approvals required by the Contract Documents except:~~
- ~~1. for inspections, tests, or approvals covered by Paragraphs 13.03.C and 13.03.D below;~~
 - ~~2. that costs incurred in connection with tests or inspections conducted pursuant to Paragraph 13.04.B shall be paid as provided in Paragraph 13.04.C; and~~
 - ~~3. as otherwise specifically provided in the Contract Documents.~~
- B. The Bidder shall obtain and employ an independent testing laboratory to provide the services specified herein and shall include all costs for these services in the contract price. The Bidder

shall submit for approval by the County and Engineer, the independent testing laboratory, including qualifications.

Copies of all testing agency invoices submitted to the Bidder for payment shall be forwarded with the Bidder's request for partial payment. Invoices shall be submitted routinely throughout the project and shall be pertinent to the partial payment period under consideration. Testing agency invoices in excess of sixty (60) days old shall not be considered for payment. Invoices shall clearly indicate type and amount of test performed, unit and total cost, and shall indicate if the invoiced testing cost is a result of retests required due to the Bidder's failure to achieve specified requirements. The cost of retesting due to test failure will be borne by the Bidder. Payment to Bidder for testing shall not be made without the required itemized invoicing. (see SC-13.03.B)

- C. If Laws or Regulations of any public body having jurisdiction require any Work (or part thereof) specifically to be inspected, tested, or approved by an employee or other representative of such public body, Bidder shall assume full responsibility for arranging and obtaining such inspections, tests, or approvals, pay all costs in connection therewith, and furnish Engineer of Record and/or Project Manager the required certificates of inspection or approval.
- D. Bidder shall be responsible for arranging and obtaining and shall pay all costs in connection with any inspections, tests, or approvals required for County's and Engineer of Record's acceptance of materials or equipment to be incorporated in the Work; or acceptance of materials, mix designs, or equipment submitted for approval prior to Bidder's purchase thereof for incorporation in the Work. Such inspections, tests, or approvals shall be performed by organizations acceptable to County and Engineer.
- E. If any Work (or the work of others) that is to be inspected, tested, or approved is covered by Bidder without written concurrence of Engineer, Bidder shall, if requested by Engineer, uncover such Work for observation.
- F. Uncovering Work as provided in Paragraph 13.03.E shall be at Bidder's expense unless Bidder has given Engineer of Record and/or Project Manager timely notice of Bidder's intention to cover the same and Engineer of Record and/or Project Manager has not acted with reasonable promptness in response to such notice.

13.04 *Uncovering Work*

- A. If any Work is covered contrary to the written request of Engineer of Record, it must, if requested by Engineer of Record, be uncovered for Engineer of Record's observation and replaced at Bidder's expense.
- B. If Engineer of Record considers it necessary or advisable that covered Work be observed by Engineer of Record or inspected or tested by others, Bidder, at Engineer of Record's request, shall uncover, expose, or otherwise make available for observation, inspection, or testing as Engineer of Record may require, that portion of the Work in question, furnishing all necessary labor, material, and equipment.

- C. If it is found that the uncovered Work is defective, Bidder shall pay all claims, costs, losses, and damages (including but not limited to all fees and charges of engineers, architects, attorneys, and other professionals and all court or arbitration or other dispute resolution costs) arising out of or relating to such uncovering, exposure, observation, inspection, and testing, and of satisfactory replacement or reconstruction (including but not limited to all costs of repair or replacement of work of others); and County shall be entitled to an appropriate decrease in the Contract Price. If the parties are unable to agree as to the amount thereof, County may make a Claim therefor as provided in Paragraph 10.05.
- D. If the uncovered Work is not found to be defective, Bidder shall be allowed an increase in the Contract Price or an extension of the Contract Times, or both, directly attributable to such uncovering, exposure, observation, inspection, testing, replacement, and reconstruction. If the parties are unable to agree as to the amount or extent thereof, Bidder may make a Claim therefor as provided in Paragraph 10.05.

13.05 *County May Stop the Work*

- A. If the Work is defective, or Bidder fails to supply sufficient skilled workers or suitable materials or equipment, or fails to perform the Work in such a way that the completed Work will conform to the Contract Documents, County may order Bidder to stop the Work, or any portion thereof, until the cause for such order has been eliminated; however, this right of County to stop the Work shall not give rise to any duty on the part of County to exercise this right for the benefit of Bidder, any SubContractor, any Supplier, any other individual or entity, or any surety for, or employee or agent of any of them.

13.06 *Correction or Removal of Defective Work*

- A. Promptly after receipt of written notice, Bidder shall correct all defective Work, whether or not fabricated, installed, or completed, or, if the Work has been rejected by Engineer, remove it from the Project and replace it with Work that is not defective. Bidder shall pay all claims, costs, losses, and damages (including but not limited to all fees and charges of engineers, architects, attorneys, and other professionals and all court or arbitration or other dispute resolution costs) arising out of or relating to such correction or removal (including but not limited to all costs of repair or replacement of work of others).
- B. When correcting defective Work under the terms of this Paragraph 13.06 or Paragraph 13.07, Bidder shall take no action that would void or otherwise impair County's special warranty and guarantee, if any, on said Work.

13.07 *Correction Period*

- A. If within one year after the date of Substantial Completion (or such longer period of time as may be prescribed by the terms of any applicable special guarantee required by the Contract Documents) or by any specific provision of the Contract Documents, any Work is found to be defective, or if the repair of any damages to the land or areas made available for Bidder's use by County or permitted by Laws and Regulations as contemplated in Paragraph 6.11.A is found to

be defective, Bidder shall promptly, without cost to County and in accordance with County's written instructions:

1. repair such defective land or areas; or
 2. correct such defective Work; or
 3. if the defective Work has been rejected by County, remove it from the Project and replace it with Work that is not defective, and
 4. satisfactorily correct or repair or remove and replace any damage to other Work, to the work of others or other land or areas resulting therefrom.
- B. If Bidder does not promptly comply with the terms of County's written instructions, or in an emergency where delay would cause serious risk of loss or damage, County may have the defective Work corrected or repaired or may have the rejected Work removed and replaced. All claims, costs, losses, and damages (including but not limited to all fees and charges of engineers, architects, attorneys, and other professionals and all court or arbitration or other dispute resolution costs) arising out of or relating to such correction or repair or such removal and replacement (including but not limited to all costs of repair or replacement of work of others) will be paid by Bidder.
- C. In special circumstances where a particular item of equipment is placed in continuous service before Substantial Completion of all the Work, the correction period for that item may start to run from an earlier date if so provided in the Specifications.
- D. Where defective Work (and damage to other Work resulting therefrom) has been corrected or removed and replaced under this Paragraph 13.07, the correction period hereunder with respect to such Work will be extended for an additional period of one year after such correction or removal and replacement has been satisfactorily completed.
- E. Bidder's obligations under this Paragraph 13.07 are in addition to any other obligation or warranty. The provisions of this Paragraph 13.07 shall not be construed as a substitute for, or a waiver of, the provisions of any applicable statute of limitation or repose.

13.08 *Acceptance of Defective Work*

- A. If, instead of requiring correction or removal and replacement of defective Work, County (and, prior to Engineer of Record's recommendation of final payment, Engineer) prefers to accept it, County may do so. Bidder shall pay all claims, costs, losses, and damages (including but not limited to all fees and charges of engineers, architects, attorneys, and other professionals and all court or ~~arbitration~~ or other dispute resolution costs) attributable to County's evaluation of and determination to accept such defective Work (such costs to be approved by Engineer of Record as to reasonableness) and for the diminished value of the Work to the extent not otherwise paid by Bidder pursuant to this sentence. If any such acceptance occurs prior to Engineer of Record's recommendation of final payment, a Change Order will be issued incorporating the necessary revisions in the Contract Documents with respect to the Work, and County shall be entitled to an

appropriate decrease in the Contract Price, reflecting the diminished value of Work so accepted. If the parties are unable to agree as to the amount thereof, County may make a Claim therefor as provided in Paragraph 10.05. If the acceptance occurs after such recommendation, an appropriate amount will be paid by Bidder to County. (see SC-13.08.A)

13.09 *County May Correct Defective Work*

- A. If Bidder fails within a reasonable time after written notice from Engineer of Record and/or Project Manager to correct defective Work, or to remove and replace rejected Work as required by Engineer of Record in accordance with Paragraph 13.06.A, or if Bidder fails to perform the Work in accordance with the Contract Documents, or if Bidder fails to comply with any other provision of the Contract Documents, County may, after seven days written notice to Bidder, correct, or remedy any such deficiency.
- B. In exercising the rights and remedies under this Paragraph 13.09, County shall proceed expeditiously. In connection with such corrective or remedial action, County may exclude Bidder from all or part of the Site, take possession of all or part of the Work and suspend Bidder's services related thereto, take possession of Bidder's tools, appliances, construction equipment and machinery at the Site, and incorporate in the Work all materials and equipment stored at the Site or for which County has paid Bidder but which are stored elsewhere. Bidder shall allow County, County's representatives, agents and employees, County's other Bidders, and Engineer of Record and Engineer of Record's consultants access to the Site to enable County to exercise the rights and remedies under this Paragraph.
- C. All claims, costs, losses, and damages (including but not limited to all fees and charges of engineers, architects, attorneys, and other professionals and all court ~~or arbitration~~ or other dispute resolution costs) incurred or sustained by County in exercising the rights and remedies under this Paragraph 13.09 will be charged against Bidder, and a Change Order will be issued incorporating the necessary revisions in the Contract Documents with respect to the Work; and County shall be entitled to an appropriate decrease in the Contract Price. If the parties are unable to agree as to the amount of the adjustment, County may make a Claim therefor as provided in Paragraph 10.05. Such claims, costs, losses and damages will include but not be limited to all costs of repair, or replacement of work of others destroyed or damaged by correction, removal, or replacement of Bidder's defective Work. (see SC-13.09.C)
- D. Bidder shall not be allowed an extension of the Contract Times because of any delay in the performance of the Work attributable to the exercise by County of County's rights and remedies under this Paragraph 13.09.

ARTICLE 14 – PAYMENTS TO BIDDER AND COMPLETION

14.01 *Schedule of Values*

- A. The Schedule of Values established as provided in Paragraph 2.07.A will serve as the basis for progress payments and will be incorporated into a form of Application for Payment acceptable to Engineer. Progress payments on account of Unit Price Work will be based on the number of units completed.

14.02 Progress Payments

A. Applications for Payments:

1. At least 20 days before the date established in the Agreement for each progress payment (but not more often than once a month), Bidder shall submit to Engineer of Record and/or Project Manager for review an Application for Payment filled out and signed by Bidder covering the Work completed as of the date of the Application and accompanied by such supporting documentation as is required by the Contract Documents. If payment is requested on the basis of materials and equipment not incorporated in the Work but delivered and suitably stored at the Site or at another location agreed to in writing, the Application for Payment shall also be accompanied by a bill of sale, invoice, or other documentation warranting that County has received the materials and equipment free and clear of all Liens and evidence that the materials and equipment are covered by appropriate property insurance or other arrangements to protect County's interest therein, all of which must be satisfactory to County.
- ~~2. Beginning with the second Application for Payment, each Application shall include an affidavit of Bidder stating that all previous progress payments received on account of the Work have been applied on account to discharge Bidder's legitimate obligations associated with prior Applications for Payment.~~ Beginning with the second Application for Payment, each Application shall include an affidavit of Bidder certifying that Bidder has disbursed to all SubContractors and suppliers having an interest in the contract their pro rata share of the payment out of previous progress payments received by Bidder for all work completed and materials furnished in the previous work period, less a retainage withheld by Bidder pursuant to an agreement with a SubContractor. Within 30 days of receipt for the final progress payment or any other payments received thereafter except the final payment, Bidder shall pay all SubContractors and suppliers having an interest in the contract their pro rata shares of the payment for all work completed and materials furnished. (see SC-14.02.A.2)
3. The amount of retainage with respect to progress payments will be as stipulated in the Agreement.

B. Review of Applications:

1. Engineer of Record and/or Project Manager will, within 10 days after receipt of each Application for Payment, either indicate in writing a recommendation of payment and present the Application to County or return the Application to Bidder indicating in writing Engineer of Record and/or Project Manager's reasons for refusing to recommend payment. In the latter case, Bidder may make the necessary corrections and resubmit the Application or direct Engineer of Record and/or Project Manager to present the Application to County with Engineer of Record and/or Project Manager's recommendation of partial payment. (see SC-14.02.B.1)
2. Engineer of Record and/or Project Manager's recommendation of any payment requested in an Application for Payment will constitute a representation by Engineer of Record to County, based on Engineer of Record and/or Project Manager's observations of the executed Work as an experienced and qualified design professional, and on Engineer of Record and/or Project

Manager's review of the Application for Payment and the accompanying data and schedules and the Contract Documents (see SC-14.02.B2), that to the best of Engineer of Record and/or Project Manager's knowledge, information and belief:

- a. the Work has progressed to the point indicated;
 - b. the quality of the Work is generally in accordance with the Contract Documents (subject to an evaluation of the Work as a functioning whole prior to or upon Substantial Completion, the results of any subsequent tests called for in the Contract Documents, a final determination of quantities and classifications for Unit Price Work under Paragraph 9.07, and any other qualifications stated in the recommendation); and
 - c. the conditions precedent to Bidder's being entitled to such payment appear to have been fulfilled in so far as it is Engineer of Record and/or Project Manager's responsibility to observe the Work.
 - d. Bidder's other obligations under the Contract Documents have been fulfilled. (see SC-14.02.B.2.d)
3. By recommending any such payment Engineer of Record and/or Project Manager will not thereby be deemed to have represented that:
- a. inspections made to check the quality or the quantity of the Work as it has been performed have been exhaustive, extended to every aspect of the Work in progress, or involved detailed inspections of the Work beyond the responsibilities specifically assigned to Engineer of Record in the Contract Documents; or
 - b. there may not be other matters or issues between the parties that might entitle Bidder to be paid additionally by County or entitle County to withhold payment to Bidder.
4. Neither Engineer of Record's review of Bidder's Work for the purposes of recommending payments nor Engineer of Record's recommendation of any payment, including final payment, will impose responsibility on Engineer:
- a. to supervise, direct, or control the Work, or
 - b. for the means, methods, techniques, sequences, or procedures of construction, or the safety precautions and programs incident thereto, or
 - c. for Bidder's failure to comply with Laws and Regulations applicable to Bidder's performance of the Work, or
 - d. to make any examination to ascertain how or for what purposes Bidder has used the moneys paid on account of the Contract Price, or
 - e. to determine that title to any of the Work, materials, or equipment has passed to County free and clear of any Liens.

5. Engineer of Record and/or Project Manager may refuse to recommend the whole or any part of any payment if, in Engineer of Record and/or Project Manager's opinion, it would be incorrect to make the representations to County stated in Paragraph 14.02.B.2. Engineer of Record and/or Project Manager may also refuse to recommend any such payment or, because of subsequently discovered evidence or the results of subsequent inspections or tests, revise or revoke any such payment recommendation previously made, to such extent as may be necessary in Engineer of Record and/or Project Manager's opinion to protect County from loss because:
 - a. the Work is defective, or completed Work has been damaged, requiring correction or replacement;
 - b. the Contract Price has been reduced by Change Orders;
 - c. County has been required to correct defective Work or complete Work in accordance with Paragraph 13.09; or
 - d. Engineer of Record has actual knowledge of the occurrence of any of the events enumerated in Paragraph 15.02.A.

C. *Payment Becomes Due:*

1. The Application for Payment once received by the County with Engineer of Record and/or Project Manager's recommendation and approval, will (subject to the provisions of Paragraph 14.02.D) become due as stipulated in Florida Statutes 218.735.

D. *Reduction in Payment:*

1. County may refuse to make payment of the full amount recommended by Engineer of Record and/or Project Manager because:
 - a. claims have been made against County on account of Bidder's performance or furnishing of the Work;
 - b. Liens have been filed in connection with the Work, except where Bidder has delivered a specific bond satisfactory to County to secure the satisfaction and discharge of such Liens;
 - c. there are other items entitling County to a set-off against the amount recommended; or
 - d. County has actual knowledge of the occurrence of any of the events enumerated in Paragraphs 14.02.B.5.a through 14.02.B.5.c or Paragraph 15.02.A.
2. If County refuses to make payment of the full amount recommended by Engineer, County will give Bidder immediate written notice (with a copy to Engineer) stating the reasons for such action and promptly pay Bidder any amount remaining after deduction of the amount so withheld. County shall promptly pay Bidder the amount so withheld, or any adjustment thereto agreed to by County and Bidder, when Bidder remedies the reasons for such action.

3. Upon a subsequent determination that County's refusal of payment was not justified, the amount wrongfully withheld shall be treated as an amount due as determined by Paragraph 14.02.C.1 and subject to interest as provided in the Agreement.

14.03 *Bidder's Warranty of Title*

- A. Bidder warrants and guarantees that title to all Work, materials, and equipment covered by any Application for Payment, whether incorporated in the Project or not, will pass to County no later than the time of payment free and clear of all Liens.

14.04 *Substantial Completion*

- A. When Bidder considers the entire Work ready for its intended use Bidder shall notify County and Engineer of Record and/or Project Manager in writing that the entire Work is substantially complete (except for items specifically listed by Bidder as incomplete) and request that Engineer of Record and/or Project Manager issue a certificate of Substantial Completion.
- B. Promptly after Bidder's notification, County, Bidder, and Engineer of Record and/or Project Manager shall make an inspection of the Work to determine the status of completion. If Engineer of Record and/or Project Manager does not consider the Work substantially complete, Engineer of Record and/or Project Manager will notify Bidder in writing giving the reasons therefor.
- C. If Engineer of Record and/or Project Manager considers the Work substantially complete, Engineer of Record and/or Project Manager will deliver to County a tentative certificate of Substantial Completion which shall fix the date of Substantial Completion. There shall be attached to the certificate a tentative list of items to be completed or corrected before final payment. County shall have seven days after receipt of the tentative certificate during which to make written objection to Engineer of Record and/or Project Manager as to any provisions of the certificate or attached list. If, after considering such objections, Engineer of Record and/or Project Manager concludes that the Work is not substantially complete, Engineer of Record and/or Project Manager will, within 14 days after submission of the tentative certificate to County, notify Bidder in writing, stating the reasons therefor. If, after consideration of County's objections, Engineer of Record and/or Project Manager considers the Work substantially complete, Engineer of Record and/or Project Manager will, within said 14 days, execute and deliver to County and Bidder a definitive certificate of Substantial Completion (with a revised tentative list of items to be completed or corrected) reflecting such changes from the tentative certificate as Engineer of Record and/or Project Manager believes justified after consideration of any objections from County.
- D. At the time of delivery of the tentative certificate of Substantial Completion, Engineer of Record and/or Project Manager will deliver to County and Bidder a written recommendation as to division of responsibilities pending final payment between County and Bidder with respect to security, operation, safety, and protection of the Work, maintenance, heat, utilities, insurance, and warranties and guarantees. Unless County and Bidder agree otherwise in writing and so inform Engineer of Record and/or Project Manager in writing prior to Engineer of Record and/or Project Manager's issuing the definitive certificate of Substantial Completion, Engineer of Record and/or

Project Manager's aforesaid recommendation will be binding on County and Bidder until final payment.

- E. County shall have the right to exclude Bidder from the Site after the date of Substantial Completion subject to allowing Bidder reasonable access to remove its property and complete or correct items on the tentative list.

14.05 *Partial Utilization*

- A. Prior to Substantial Completion of all the Work, County may use or occupy any substantially completed part of the Work which has specifically been identified in the Contract Documents, or which County, Engineer of Record and/or Project Manager, and Bidder agree constitutes a separately functioning and usable part of the Work that can be used by County for its intended purpose without significant interference with Bidder's performance of the remainder of the Work, subject to the following conditions:
 - 1. County at any time may request Bidder in writing to permit County to use or occupy any such part of the Work which County believes to be ready for its intended use and substantially complete. If and when Bidder agrees that such part of the Work is substantially complete, Bidder, County, and Engineer of Record and/or Project Manager will follow the procedures of Paragraph 14.04.A through D for that part of the Work.
 - 2. Bidder at any time may notify County and Engineer of Record and/or Project Manager in writing that Bidder considers any such part of the Work ready for its intended use and substantially complete and request Engineer of Record and/or Project Manager to issue a certificate of Substantial Completion for that part of the Work.
 - 3. Within a reasonable time after either such request, County, Bidder, and Engineer of Record and/or Project Manager shall make an inspection of that part of the Work to determine its status of completion. If Engineer of Record and/or Project Manager does not consider that part of the Work to be substantially complete, Engineer of Record and/or Project Manager will notify County and Bidder in writing giving the reasons therefor. If Engineer of Record and/or Project Manager considers that part of the Work to be substantially complete, the provisions of Paragraph 14.04 will apply with respect to certification of Substantial Completion of that part of the Work and the division of responsibility in respect thereof and access thereto.
 - ~~4. No use or occupancy or separate operation of part of the Work may occur prior to compliance with the requirements of Paragraph 5.10 regarding property insurance. (see SC.14.5.A.4)~~

14.06 *Final Inspection*

- A. Upon written notice from Bidder that the entire Work or an agreed portion thereof is complete, Engineer of Record will promptly make a final inspection with County and Bidder and will notify Bidder in writing of all particulars in which this inspection reveals that the Work is incomplete or defective. Bidder shall immediately take such measures as are necessary to complete such Work or remedy such deficiencies.

14.07 *Final Payment/Release of Retainage*

A. Application for Payment:

1. After Bidder has, in the opinion of Engineer of Record and/or Project Manager, satisfactorily completed all corrections identified during the final inspection and has delivered, in accordance with the Contract Documents, all maintenance and operating instructions, schedules, guarantees, bonds, certificates or other evidence of insurance, certificates of inspection, marked-up record documents (as provided in Paragraph 6.12), and other documents, Bidder may make application for final payment following the procedure for progress payments.
2. The final Application for Payment shall be accompanied (except as previously delivered) by:
 - a. all documentation called for in the Contract Documents, including but not limited to the evidence of insurance required by Paragraph 5.04.B.6;
 - b. consent of the surety, if any, to final payment;
 - c. a list of all Claims against County that Bidder believes are unsettled; and
 - d. complete and legally effective releases or waivers (satisfactory to County) of all Lien rights arising out of or Liens filed in connection with the Work.
3. In lieu of the releases or waivers of Liens specified in Paragraph 14.07.A.2 and as approved by County, Bidder may furnish receipts or releases in full and an affidavit of Bidder that: (i) the releases and receipts include all labor, services, material, and equipment for which a Lien could be filed; and (ii) all payrolls, material and equipment bills, and other indebtedness connected with the Work for which County might in any way be responsible, or which might in any way result in liens or other burdens on County's property, have been paid or otherwise satisfied. If any SubContractor or Supplier fails to furnish such a release or receipt in full, Bidder may furnish a bond or other collateral satisfactory to County to indemnify County against any Lien.

B. Engineer of Record and/or Project Manager's Review of Application and Acceptance:

1. If, on the basis of Engineer of Record and/or Project Manager's observation of the Work during construction and final inspection, and Engineer of Record and/or Project Manager's review of the final Application for Payment and accompanying documentation as required by the Contract Documents, Engineer of Record and/or Project Manager is satisfied that the Work has been completed and Bidder's other obligations under the Contract Documents have been fulfilled, Engineer of Record and/or Project Manager will, within ten days after receipt of the final Application for Payment, indicate in writing Engineer of Record and/or Project Manager's recommendation of payment and present the Application for Payment to County for payment. At the same time Engineer of Record and/or Project Manager will also give written notice to County and Bidder that the Work is acceptable subject to the provisions of Paragraph 14.09. Otherwise, Engineer of Record and/or Project Manager will return the

Application for Payment to Bidder, indicating in writing the reasons for refusing to recommend final payment, in which case Bidder shall make the necessary corrections and resubmit the Application for Payment.

C. *Payment Becomes Due:*

1. The Application for Payment once received by the County with Engineer of Record and/or Project Manager's recommendation and approval, will become due as stipulated in Florida Statutes 218.735. This payment must also be placed on an agenda for approval by the County before release of final payment.

14.08 *Final Completion Delayed*

- A. If, through no fault of Bidder, final completion of the Work is significantly delayed, and if Engineer of Record and/or Project Manager so confirms, County shall, upon receipt of Bidder's final Application for Payment (for Work fully completed and accepted) and recommendation of Engineer of Record and/or Project Manager, and without terminating the Contract, make payment of the balance due for that portion of the Work fully completed and accepted. If the remaining balance to be held by County for Work not fully completed or corrected is less than the retainage stipulated in the Agreement, and if bonds have been furnished as required in Paragraph 5.01, the written consent of the surety to the payment of the balance due for that portion of the Work fully completed and accepted shall be submitted by Bidder to Engineer of Record and/or Project Manager with the Application for such payment. Such payment shall be made under the terms and conditions governing final payment, except that it shall not constitute a waiver of Claims.

14.09 *Waiver of Claims*

- A. The making and acceptance of final payment will constitute:
 1. a waiver of all Claims by County against Bidder, except Claims arising from unsettled Liens, from defective Work appearing after final inspection pursuant to Paragraph 14.06, from failure to comply with the Contract Documents or the terms of any special guarantees specified therein, ~~or whenever said failure occurs~~ from Bidder's continuing obligations under the Contract Documents; and (see SC-14.09.A.1)
 2. a waiver of all Claims by Bidder against County other than those previously made in accordance with the requirements herein and expressly acknowledged by County in writing as still unsettled.
 3. The acceptance of final payment by Bidder designated and identified by Engineer of Record and/or Project Manager as final payment shall be and shall operate as a release to County of all claims and all liability to Bidder other than claims in stated amounts as may be specifically excepted by Bidder for all things done or finished in connection with the Work and for every act of County and others relating to or arising out of the Work. Any payment, however, final or otherwise, shall not release Bidder or Bidder's Surety(ies) from any obligations under the Contract Documents or Bonds. (see SC-14.09.A.3)

ARTICLE 15 – SUSPENSION OF WORK AND TERMINATION**15.01 County May Suspend Work**

- A. At any time and without cause, County may suspend the Work or any portion thereof for a period of not more than 90 consecutive days by notice in writing to Bidder and Engineer of Record which will fix the date on which Work will be resumed. Bidder shall resume the Work on the date so fixed. Bidder shall be granted an adjustment in the Contract Price or an extension of the Contract Times, or both, directly attributable to any such suspension if Bidder makes a Claim therefor as provided in Paragraph 10.05.

15.02 County May Terminate for Cause

- A. The occurrence of any one or more of the following events will justify termination for cause:
1. Bidder's start the work in accordance with the Notice to Proceed or Bidder's persistent failure to perform the Work in accordance with the Contract Documents (including, but not limited to, failure to supply sufficient skilled workers or suitable materials or equipment or failure to adhere to the Progress Schedule established under Paragraph 2.07 as adjusted from time to time pursuant to Paragraph 6.04) (see SC-15.02.A.1);
 2. Bidder's disregard of Laws or Regulations of any public body having jurisdiction;
 3. Bidder's repeated disregard of the authority of Engineer of Record; or
 4. Bidder's violation in any substantial way of any provisions of the Contract Documents.
- B. If one or more of the events identified in Paragraph 15.02.A occur, County may, after giving Bidder (and surety) seven days written notice of its intent to terminate the services of Bidder:
1. exclude Bidder from the Site, and take possession of the Work and of all Bidder's tools, appliances, construction equipment, and machinery at the Site, and use the same to the full extent they could be used by Bidder (without liability to Bidder for trespass or conversion);
 2. incorporate in the Work all materials and equipment stored at the Site or for which County has paid Bidder but which are stored elsewhere; and
 3. complete the Work as County may deem expedient.
- C. If County proceeds as provided in Paragraph 15.02.B, Bidder shall not be entitled to receive any further payment until the Work is completed. If the unpaid balance of the Contract Price exceeds all claims, costs, losses, and damages (including but not limited to all fees and charges of engineers, architects, attorneys, and other professionals and all court or arbitration or other dispute resolution costs) sustained by County arising out of or relating to completing the Work, such excess will be paid to Bidder. If such claims, costs, losses, and damages exceed such unpaid balance, Bidder shall pay the difference to County. Such claims, costs, losses, and damages incurred by County will be reviewed by Engineer of Record as to their reasonableness and, when so approved by Engineer of Record, incorporated in a Change Order. When exercising any

rights or remedies under this Paragraph, County shall not be required to obtain the lowest price for the Work performed.

- D. Notwithstanding Paragraphs 15.02.B and 15.02.C, Bidder's services will not be terminated if Bidder begins within seven days of receipt of notice of intent to terminate to correct its failure to perform and proceeds diligently to cure such failure within no more than 30 days of receipt of said notice.
- E. Where Bidder's services have been so terminated by County, the termination will not affect any rights or remedies of County against Bidder then existing or which may thereafter accrue. Any retention or payment of moneys due Bidder by County will not release Bidder from liability.
- F. If and to the extent that Bidder has provided a performance bond under the provisions of Paragraph 5.01.A, the termination procedures of that bond shall supersede the provisions of Paragraphs 15.02.B and 15.02.C.

15.03 *County May Terminate For Convenience*

- A. Upon seven days written notice to Bidder and Engineer of Record, County may, without cause and without prejudice to any other right or remedy of County, terminate the Contract. In such case, Bidder shall be paid for (without duplication of any items):
 - 1. completed and acceptable Work executed in accordance with the Contract Documents prior to the effective date of termination, including fair and reasonable sums for overhead and profit on such Work;
 - 2. expenses sustained prior to the effective date of termination in performing services and furnishing labor, materials, or equipment as required by the Contract Documents in connection with uncompleted Work, plus fair and reasonable sums for overhead and profit on such expenses;
 - 3. all claims, costs, losses, and damages (including but not limited to all fees and charges of engineers, architects, attorneys, and other professionals and all court or arbitration or other dispute resolution costs) incurred in settlement of terminated contracts with SubContractors, Suppliers, and others; and
 - 4. reasonable expenses directly attributable to termination.
- B. Bidder shall not be paid on account of loss of anticipated profits or revenue or other economic loss arising out of or resulting from such termination.

15.04 *Bidder May Stop Work or Terminate*

- A. If, through no act or fault of Bidder, (i) the Work is suspended for more than 90 consecutive days by County or under an order of court or other public authority, or (ii) Engineer of Record and/or Project Manager fails to act on any Application for Payment within 30 days after it is submitted, or (iii) County fails for 45 days to pay Bidder any sum finally determined to be due, then Bidder

may, upon seven days written notice to County and Engineer of Record and/or Project Manager, and provided County or Engineer of Record and/or Project Manager do not remedy such suspension or failure within that time, terminate the Contract and recover from County payment on the same terms as provided in Paragraph 15.03.

- B. In lieu of terminating the Contract and without prejudice to any other right or remedy, if Engineer of Record and/or Project Manager has failed to act on an Application for Payment within 30 days after it is submitted, or County has failed for 45 days to pay Bidder any sum finally determined to be due, Bidder may, seven days after written notice to County and Engineer of Record and/or Project Manager, stop the Work until payment is made of all such amounts due Bidder, including interest thereon. The provisions of this Paragraph 15.04 are not intended to preclude Bidder from making a Claim under Paragraph 10.05 for an adjustment in Contract Price or Contract Times or otherwise for expenses or damage directly attributable to Bidder's stopping the Work as permitted by this Paragraph.

ARTICLE 16 – DISPUTE RESOLUTION

16.01 Methods and Procedures

- A. Either County or Bidder may request mediation of any Claim submitted to Engineer of Record for a decision under Paragraph 10.05 before such decision becomes final and binding. The mediation will be governed by the Construction Industry Mediation Rules of the American Arbitration Association in effect as of the Effective Date of the Agreement. The request for mediation shall be submitted in writing to the American Arbitration Association and the other party to the Contract. Timely submission of the request shall stay the effect of Paragraph 10.05.E.
- B. County and Bidder shall participate in the mediation process in good faith. The process shall be concluded within 60 days of filing of the request. The date of termination of the mediation shall be determined by application of the mediation rules referenced above.
- C. If the Claim is not resolved by mediation, Engineer of Record's action under Paragraph 10.05.C or a denial pursuant to Paragraphs 10.05.C.3 or 10.05.D shall become final and binding 30 days after termination of the mediation unless, within that time period, County or Bidder:
1. elects in writing to invoke any dispute resolution process provided for in the Supplementary Conditions; or
 2. agrees with the other party to submit the Claim to another dispute resolution process; or
 3. gives written notice to the other party of the intent to submit the Claim to a court of competent jurisdiction.
- D. Venue for any mediation shall be in Nassau County, Florida. Venue for any litigation shall be in state court in Nassau County, Florida.

ARTICLE 17 – MISCELLANEOUS**17.01 *Giving Notice***

- A. Whenever any provision of the Contract Documents requires the giving of written notice, it will be deemed to have been validly given if:
1. delivered in person to the individual or to a member of the firm or to an officer of the corporation for whom it is intended; or
 2. delivered at or sent by registered or certified mail, postage prepaid, to the last business address known to the giver of the notice.

17.02 *Computation of Times*

- A. When any period of time is referred to in the Contract Documents by days, it will be computed to exclude the first and include the last day of such period. If the last day of any such period falls on a Saturday or Sunday or on a day made a legal holiday by the law of the applicable jurisdiction, such day will be omitted from the computation.

17.03 *Cumulative Remedies*

- A. The duties and obligations imposed by these General Conditions and the rights and remedies available hereunder to the parties hereto are in addition to, and are not to be construed in any way as a limitation of, any rights and remedies available to any or all of them which are otherwise imposed or available by Laws or Regulations, by special warranty or guarantee, or by other provisions of the Contract Documents. The provisions of this Paragraph will be as effective as if repeated specifically in the Contract Documents in connection with each particular duty, obligation, right, and remedy to which they apply.

17.04 *Survival of Obligations*

- A. All representations, indemnifications, warranties, and guarantees made in, required by, or given in accordance with the Contract Documents, as well as all continuing obligations indicated in the Contract Documents, will survive final payment, completion, and acceptance of the Work or termination or completion of the Contract or termination of the services of Bidder.

17.05 *Controlling Law*

- A. This Contract is to be governed by the law of the state in which the Project is located.

17.06 *Headings*

- A. Article and paragraph headings are inserted for convenience only and do not constitute parts of these General Conditions.

SECTION 00 73 15**SUPPLEMENTARY CONDITIONS**

These Supplementary Conditions amend or supplement the Standard General Conditions of the Construction Contract (EJCDC C-700, 2007 Edition). All provisions which are not so amended or supplemented remain in full force and effect.

The terms used in these Supplementary Conditions which are defined in the Standard General Conditions of the Construction Contract have the meanings assigned to them in the General Conditions.

ARTICLE 1 DEFINITIONS AND TERMINOLOGY

SC-1.01.21 Amend the Defined Terms for *General Requirements* to The General Requirements pertain to all Sections of the specifications.

Add the following new paragraph immediately after paragraph 1.01.51:

SC-1 .01.52 SURETY – The person, firm, or corporation which is bound by the contract bonds with and for Bidder (Principal); and which is held and firmly bound unto County for the conditions of obligations set forth in said bonds.

ARTICLE 2 PRELIMINARY MATTERS

SC-2.02.A Amend the first sentence of paragraph 2.02.A of the General Conditions by changing “up to ten” to “five”.

SC-2.05.A Amend the first sentence of paragraph 2.05.A of the General Conditions by changing “Within 10 days after the Effective Date of the Agreement” to “At the Preconstruction Conference”.

Add the following new paragraph immediately after paragraph 2.05.A.3:

SC-2.05.B Before any Work at the Site is started, Bidder shall deliver to the County, certificates of insurance that Bidder is required to purchase and maintain in accordance with Article 5.

Add the following new paragraph immediately after paragraph 2.06.B:

SC-2.06.C County may issue Notice to Proceed at the Preconstruction Conference. Bidder shall begin the Work within twenty-four (24) hours of the date given in the Notice to Proceed. If the Bidder does not start the Work within fourteen (14) calendar days after this date, County may, at his discretion, terminate Bidder in accordance with paragraph 15.02.

Delete paragraph 2.07.A in its entirety and insert the following in its place:

SC-2.07.A All schedules as set forth in Article 2 shall be submitted and accepted by the County and Engineer of Record and/or Project Manager within 30 days of NTP. Should any schedule not be accepted within 30 days of the NTP, it will be considered a breach of contract and reason for termination of the contract for cause in accordance with the General Conditions, Section 15.02.

ARTICLE 4 AVAILABILITY OF LANDS; SUBSURFACE AND PHYSICAL CONDITIONS; HAZARDOUS ENVIRONMENTAL CONDITIONS; REFERENCE POINTS

Add the following to the end of paragraph 4.01.C:

SC-4.01.C Bidder shall obtain said land rights at his own expense and without liability to the County. Bidder shall not enter upon private property without first obtaining written permission from the rightful property County.

Add the following new paragraph immediately after paragraph 4.02.B:

SC-4.02.C In the preparation of Drawings and Specifications, Engineer of Record or Engineer of Record's Consultants relied upon the following report(s) of explorations and tests of subsurface conditions at the Site:

- NO GEOTECHINCAL LISTED

Amend the last sentence in paragraph 4.03.C.3 to read:

SC-4.03.C.3 However, County, Engineer of Record and Engineer of Record's Consultants shall not be liable to Bidder for any claims, costs, losses, or damages (including but not limited to all fees and charges of engineers, architects, attorneys, and other professionals and all court or other dispute resolution costs) sustained by Bidder on or in connection with any other project or anticipated project.

ARTICLE 5 BONDS AND INSURANCE

Delete paragraph 5.01.B in its entirety and insert the following in its place:

SC-5.01.B All Bonds shall be in the form prescribed by the Contract Documents or other form approved by County. All else notwithstanding, the terms of all Bonds shall be substantially in the form prescribed by Chapter 255, Florida Statutes. All Bonds shall be executed by Bidder and a corporate bonding company licensed to transact such business in the State of Florida and named on the current list of "Surety Companies Acceptable on Federal Bonds" as published in the Treasury Department Circular Number 570. Bidder will cause the Bonds to be recorded with the Clerk of the Circuit Court in the county in which the Work is to be performed. Failure to execute bonds in the form prescribed may constitute non-responsiveness on the part of the Bidder. The expense for all Bonds shall be the Bidder's responsibility.

Add the following to the end of paragraph 5.02.A:

SC-5.02.A Certificates of insurance shall be issued by a company with a Best's rating of at least B+ authorized to do business in the State of Florida. County must approve non-rated insurers. If used, County shall be shown as Certificate Holder, Engineer as Additional Insured and provide a 30-day cancellation notice.

Delete paragraph 5.03.B in its entirety and insert the following in its place:

SC-5.03.B Insurance policies written on a "Claims Made" form is not acceptable without County's approval.

Add the following new paragraphs immediately after paragraph 5.03.E:

SC-5.03.F Umbrella Liability insurance is preferred, but an Excess Liability equivalent is acceptable. Whichever type of coverage is provided, it shall not be more restrictive than the underlying insurance policy coverages, including, but not limited to the coverage Trigger, defense, notice of occurrence/accident/circumstances, notice of claim and extended reporting period.

SC-5.03.G No work shall commence under this contract until the required Certificate(s) have been provided. Work shall not continue after expiration (or cancellation) until new Certificate(s) have been provided. Non-continuance of work after expiration (or cancellation) of Certificate(s) will not constitute a delay beyond Bidder's control as defined in paragraph 12.03.

SC-5.03.H Bidder shall arrange for its insurers' policies to include, or be endorsed to include, a severability or interest/cross liability provision, so that County will be

treated as if a separate policy were in existence, but without increasing the policy limits.

- SC-5.03.I Bidder's deductibles/self-insured retentions shall be disclosed to County and may be disapproved by the latter. They shall be reduced or eliminated at the option of County. Bidder is responsible for the amount of any deductible or self-insured retention.
- SC-5.03.J These insurance requirements shall not relieve or limit the liability of Bidder. County does not in any way represent that these types or amounts of insurance are sufficient or adequate to protect Bidder's interests or liabilities, but are merely minimums.
- SC-5.03.K Insurance required of Bidder or any other insurance of Bidder shall be considered primary, and insurance or self-insurance of County shall be considered excess, as may be applicable to claims that arise out of this contract.
- SC-5.03.L Receipt of Certificates or other documentation of insurance or policies or copies of policies by County, or by any of its representatives, which indicate less coverage than required does not constitute a waiver of the Bidder's obligation to fulfill the insurance requirements herein.
- SC-5.03. M The Bidder shall either (a) require each subcontractor to produce and maintain the same coverage as required of the Bidder, or (b) insure the activities of subcontractor in his own policy.
- SC-5.03.N These insurance requirements are minimums and may not be adequate to cover Bidder exposures.

Add the following new paragraphs immediately after paragraph 5.04.B:

- SC-5.04.C The limits of liability for the insurance required by paragraph 5.04 of the General Conditions shall provide coverage for not less than the amounts shown in Exhibit 1 of the contract documents, or greater where required by Laws and Regulations.

Delete paragraphs 5.06 through 5.10 in their entirety except for paragraph 5.06.D and insert the following in place of 5.09.A:

- SC-5.09.A If County has any objection to the coverage afforded by or other provisions of Bonds or insurance required to be purchased and maintained by Bidder in accordance with Article 5 on the basis of non-conformance with the Contract

Documents, County shall so notify Bidder in writing within ten days after receipt of the certificates (or other evidence requested) required by paragraph 2.05.C. Bidder shall provide to County such additional information in respect of insurance provided as County may reasonably request.

ARTICLE 6 BIDDER'S RESPONSIBILITIES

Add the following to the end of paragraph 6.01.A:

SC-6.01.A County reserves the right to reject any means, methods, techniques, sequences or procedures proposed by Bidder which:

1. will constitute or create a hazard to the Work or to the persons or damage to property or existing utilities; or
2. will not produce finished work in accordance with the terms of the contract Documents.

County's failure to exercise his right to reject such means, methods, techniques, sequences or procedures shall not relieve the Bidder of his obligation to accomplish the result intended in the Contract Documents nor shall the exercise of such right create a cause of action for damages.

Add the following new paragraph immediately after paragraph 6.02.B:

SC-6.02.C Engineer of Record and/or Project Manager shall record time and costs required by Engineer of Record and/or Project Manager and Engineer of Record's Consultants to provide inspection services due to Bidder's working beyond regular working hours as defined in the General Requirements. County's reimbursement for the charges shall be a deduction from Bidder's Partial Payment(s) in accordance with Section 01 11 00 Part 2.02.

Add the following new paragraphs immediately after paragraph 6.05.A.2.d:

SC-6.05.A.2.e Each action mentioned above required for review of proposed substitute items of material or equipment shall be followed in the order given. Failure to do so shall be cause for rejection of the proposed substitution.

SC-6.05.A.2.f Bidder shall reimburse County for the charges of Engineer of Record and/or Project Manager or Engineer of Record's Consultants for evaluation of substitutions. County's reimbursement for the charges shall be a deduction from the Bidder's Partial Payment(s).

Add the following to the end of paragraph 6.06.A:

SC -6.06.A Bidder shall not subcontract part(s) or the work, the aggregate cost of which is greater than 50 percent of the contract price, without prior written approval by County. Bidder shall cause appropriate provisions to be inserted in all subcontracts relative to the Work that bind Subcontractor to Bidder by the terms of the Contract Documents insofar as applicable to the work of Subcontractors and to give Bidder the same power as regards terminating any subcontract that County may exercise over Bidder under any provision of the Contract Documents. Nothing contained in the subcontract shall create any contractual relationship between Subcontractor and County. Each Subcontractor shall discharge all duties and responsibilities of Bidder to County covered by his subcontract.

Add the following to the end of paragraph 6.06.B:

SC-6.06.B Subcontractors and Suppliers shall be identified on the form provided in the Bidding Requirements.

Add the following to the end of paragraph 6.08.A:

SC-6.08.A Permits, licenses, and easements for permanent structures or permanent changes in existing facilities shall be secured and paid for by County, unless otherwise specified.

Add the following to the end of paragraph 6.09.A:

SC-6.09.A Bidder shall also cause all Subcontractors to comply with all federal, state, county, and municipal laws, ordinances, rules, and regulations bearing on the conduct of the Work.

Add the following to the end of paragraph 6.09.B:

SC-6.09.B If Bidder observes that the Contract Documents are at variance with said laws, ordinances, rates, or regulations, Bidder shall promptly notify Engineer of Record and the County in writing, and any necessary changes shall be adjusted as provided in the Contract Documents. Bidder shall not proceed with the Work until so instructed by County.

Add the following to the end of paragraph 6.12.A:

SC-6.12.A Annotations of record documents shall be legible, precise, and complete as determined by Engineer of Record and the County.

Add the following new paragraph after paragraph 6.13.D:

SC-6.13.G Bidder shall be responsible at all times for precautions to achieve the protection of all persons, including employees and property. Bidder shall make special effort to detect hazardous conditions and shall take prompt action where necessary to avoid accident, injury, or property damage. OSHA and all other applicable safety laws and ordinances shall be followed as well as American National Standards Institute Safety Standards. All accidents, injuries, claims, or potential claims shall be reported promptly to County.

Add the following new paragraph immediately after paragraph 6.17.E.1:

SC-6.17.E.2 Bidder shall reimburse County for the charges of the County and the County's Consultants for costs generated as a result of more than two submittals of any one Shop Drawing or Sample being required for evaluation due to rejection for noncompliance of the original submittal or lack of information required by the Contract Documents. County's reimbursement for the charges shall be a deduction from Bidder's Partial Payment(s).

SC-6.20.A Amend the first paragraph of 6.20.A of the General Conditions by changing "(including but not limited to all fees and charges of engineers, architects, attorneys, and other professionals and all court: or arbitration or other dispute resolution costs)" to "(including but not limited to all fees and charges of engineers, architects, attorneys, and other professionals and all court or other dispute resolution costs)".

Add the following new paragraph immediately after paragraph 6.20.C:

SC-6.20.D Neither Bidder nor County shall sell, transfer, assign, or otherwise dispose of the contract or any portion thereof, or any right, title, or interest therein, or any obligations thereunder, without written consent of the other party.

ARTICLE 8 COUNTY'S RESPONSIBILITIES

SC-8.02 Amend paragraph 8.02 of the General Conditions by striking out the following words: "to whom Bidder makes no reasonable objection."

ARTICLE 9 ENGINEER'S STATUS DURING CONSTRUCTION

Add the following new paragraph immediately after paragraph 9.05.A:

SC-9.05.B Bidder shall reimburse the County for the charges of Engineer of Record and Engineer of Record's Consultants for any additional field observations, engineering analysis, correspondence, meetings, or other work due to non-complying or defective construction, materials, or equipment performed or furnished by the Bidder, Subcontractors, or Suppliers. County's reimbursement for the charges shall be a deduction from the Bidder's Partial Payment(s).

ARTICLE 10 CHANGES IN THE WORK; CLAIMS

SC-10.05.B Amend the first sentence of paragraph 10.05.B of the General Conditions by changing "(but in no event later than 30 days)" to "(but in no event later than 15 days)".

ARTICLE 11 COST OF THE WORK; CASH ALLOWANCES; UNIT PRICE WORK

Add the following to the end of paragraph 11.01.A.5.c:

SC-11.01.A.5.c In no case shall rates exceed those published by the current edition of Data Quest Incorporated titled, Rental Rate Blue Book for Construction Equipment, and other procedures established by Florida Department of Transportation.

SC-11.01.A.5.f Amend the first sentence of paragraph 11.01.A.5.f by striking out the following words: "(except losses and damages within the deductible amounts of property insurance established in accordance with paragraph 5.06.D)".

Add the following new paragraphs immediately after paragraph 11.01.A.5.i:

SC-11.01.A.5.j The cost of specific consideration for the indemnifications set forth in paragraph 6.20.

SC-11.01.A.5.k The cost of compliance with current local, state and federal safety regulations.

Add the following new paragraphs immediately after paragraph 11.03.D:

SC-11.03.E If County objects to Bidder's quoted adjustment in Unit Price Work set forth in paragraph 11.03.D, County may assign such work to its own forces or another Bidder.

SC-11.03.F County reserves the right to delete any Unit Price Work without financial penalty incurred from Bidder.

ARTICLE 12 CHANGE OF CONTRACT PRICE; CHANGE OF CONTRACT TIMES

Add the following new paragraph immediately after paragraph 12.02.B:

SC-12.02.C On the 21st of each month, or the next following business day, the Bidder shall submit to the County and Engineer of Record and/or Project Manager a request for weather days. Failure to submit the request forfeits the right to claim weather days for that period and any previous period. The County will grant time extensions, on a day for day basis, for delays caused by the effects of rains or other inclement weather conditions or related adverse soil conditions that prevent the Bidder from productively performing controlling items of work resulting in:

(1) The Bidder being unable to work at least 50% of the normal work day on pre-determined controlling work items due to adverse weather conditions.

No additional compensation will be made for delays caused by the effects of inclement weather.

ARTICLE 13 TESTS AND INSPECTIONS; CORRECTION, REMOVAL OR ACCEPTANCE OF DEFECTIVE WORK

Add the following to the end of paragraph 13.03.A:

SC-13.03.A Bidder shall reimburse County for the charges of Engineer of Record and Engineer of Record's Consultants for all costs due to work not being ready for tests and/or inspections when the Bidder has notified Engineer of Record that work is ready for tests and/or inspections. Bidder shall reimburse County for all failed tests and subsequent retests. Reimbursement for the charges shall be a deduction from the Bidder's Partial Payment(s).

Delete paragraph 13.03.B of the General Conditions and add the following in its place:

SC-13.03.B The Bidder shall obtain and employ an independent testing laboratory to provide the services specified herein and shall include all costs for these services in the contract price. The Bidder shall submit for approval by the County and Engineer, the independent testing laboratory, including qualifications.

Copies of all testing agency invoices submitted to the Bidder for payment shall be forwarded with the Bidder's request for partial payment. Invoices shall be submitted routinely throughout the project and shall be pertinent to the partial payment period under consideration. Testing agency invoices in excess of sixty (60) days old shall not be considered for payment, Invoices shall clearly indicate type and amount of test performed, unit and total cost, and shall indicate if the invoiced testing cost is a result of retests required due to the Bidder's failure to achieve specified requirements. The cost of retesting due to test failure will be borne by the Bidder. Payment to the Bidder for testing shall not be made without the required itemized invoicing.

SC-13.08.A Amend the first sentence of 13.08.A by changing "(including but not limited to all fees and charges of engineers, architects, attorneys, and other professionals and all court or arbitration or other dispute resolution costs)" to "(including but not limited to all fees and charges of engineers, architects, attorneys, and other professionals and all court or other dispute resolution costs)".

SC-13.09.C Amend the first sentence of 13.09.C by changing "(including but not limited to all fees and charges of engineers, architects, attorneys, and other professionals and all court or arbitration or other dispute resolution costs)" to "(including but not limited to all fees and charges of engineers, architects, attorneys, and other professionals and all court or other dispute resolution costs)".

ARTICLE 14 PAYMENTS TO BIDDER AND COMPLETION

Delete paragraph 14.02.A.2 in its entirety and insert the following in its place:

SC-14.02.A.2 Beginning with the second Application for Payment, each Application shall include an affidavit of Bidder certifying that Bidder has disbursed to all subcontractors and suppliers having an interest in the contract their pro rata shares of the payment out of previous progress payments received by Bidder for all work completed and materials furnished in the previous work period, less a retainage withheld by Bidder pursuant to an agreement with a subcontractor. Within 30 days of receipt for the final progress payment or any other payments received thereafter except the final payment, Bidder shall pay all subcontractors and suppliers having an interest in the contract their pro rata shares of the payment for all work completed and materials furnished.

Add the following words to the end of paragraph 14.02.B.1:

“or direct Engineer to present the Application to County with Engineer's recommendation of partial payment.”

SC-14.02.B.2 After the word “schedules”, add the words “and the Contract Documents”.

Add the following new paragraph immediately after paragraph 14.02.B.2.c:

SC-14.02.B.2.d Bidder's other obligations under the Contract Documents have been fulfilled.

Delete paragraph 14.05.A.4 in its entirety

Amend paragraph 14.09.A.1 to read:

SC-14.09.A.1 A waiver of all Claims by County against Bidder, except Claims arising from unsettled Liens, from defective Work appearing after final inspection pursuant to paragraph 14.06, from failure to comply with the Contract Documents or the terms of any special guarantees specified therein whenever said failure occurs or from Bidder's continuing obligations under the Bidder Documents; and

Add the following new paragraph immediately after paragraph 14.09.A.2:

SC-14.09.A.3 The acceptance of final payment by Bidder designated and identified by Engineer of Record and/or Project Manager as final payment shall be and shall operate as a release to County of all claims and all liability to Bidder other than claims in stated amounts as may be specifically excepted by Bidder for all things done or finished in connection with the Work and for every act of County and others relating to or arising out of the Work. Any payment, however, final or otherwise, shall not release Bidder or Bidder's Surety(ies) from any obligations under the Contract Documents or Bonds.

ARTICLE 15 SUSPENSION OF WORK AND TERMINATION

SC-15.02.A. 1 After the word “Bidder's”, add the words “start the work in accordance with the Notice to Proceed or Bidder's”.

ARTICLE 16 DISPUTE RESOLUTION

Add the following new paragraph immediately after paragraph 16.01.C.3

SC-16.01.D Venue for any mediation shall be in Nassau County, Florida. Venue for any litigation shall be in state court in Nassau County, Florida.

DIVISION 01

GENERAL REQUIREMENTS

SECTION 01 11 00**SUMMARY OF WORK****PART 1 THE WORK AND ITS PERFORMANCE****1.01 CHARACTER OF THE WORK**

Unless otherwise expressly provided in the Contract Documents, the Work must be performed in accordance with best modern practice, with materials and workmanship of the highest quality to the satisfaction of the County.

1.02 DESCRIPTION OF THE PROJECT

A. The project title is: **Animal Services Cattery Addition**
Bid Number NC19-026
Nassau County, Florida

B. This project consists of labor, materials and supervision for the construction and addition of a Cattery Building at Nassau County Animal Services. The work to be performed is generally described as the construction of a new Cattery Building and includes, but is not limited to the following:

- Demolition Services and relocation of elements within the footprint of the proposed construction
- All Utility Connections (water, sewer, electrical, mechanical, including potable and DWV piping)
- Roofing
- Painting and Waterproofing
- Concrete/Foundations
- Wood Framing
- Masonry
- Plumbing
- HVAC
- Purchase and Installation of Cages

All work shall be in accordance with the construction drawings, specifications, and contract documents.

C. The specification divisions and drawings are an integrated part of the contract documents and, as such, will not stand alone if used independently as individual sections, divisions, or

drawings sheets. The drawings and specifications establish minimum standards of quality for this project. They do not purport to cover all details entering into the design and construction of materials and equipment.

PART 2 WORKING HOURS

2.01 GENERAL

Work under this contract shall not be performed on County, State and/or national holidays, except in time of emergency, and then only under written permission from the County who shall be the sole judge as to the urgency of that situation. Available workdays to perform work will not include night time work, weekend work, or work before 8:00 am. or after 5:00 pm (40 hours per work week).

Should the Bidder deem it necessary to work on Sundays, holidays, or beyond daylight hours in order to comply with his construction schedule or because of an emergency, the Bidder shall request permission of the County. If, in the opinion of the County, the need is bona fide, Nassau County will authorize the Bidder to work such hours as may be necessary.

The Bidder shall coordinate all the activities on the site with the County and Project Manager to ensure the operation of the facility is not disrupted.

2.02 LANE CLOSURES

No Lane Closures needed for this Project.

2.03 REIMBURSEMENT FEES

Should the County approve work time beyond regular hours, the following hourly rates shall be applied as the County's reimbursement of fees to be paid by Bidder for expenses defined in Supplemental Conditions SC-6.02.C, SC-6.05.A.2.f, SC-6.17.E., SC-9.05.B and SC-13.03.A.

| | |
|---|---------|
| A. Project Manager | \$46.72 |
| B. Staff Employee (providing oversight) | \$36.43 |
| C. On-call Technician | \$54.65 |

PART 3 ABBREVIATIONS**3.01 ORDINANCES, REGULATIONS, STANDARDS, AND CODES**

Reference in the specifications to known standards, codes, specifications, etc., promulgated by professional or technical associations, institutions, and societies, is intended to mean the latest edition of each such standard adopted and published as of the date of the Invitation to Bid on this project except where otherwise specifically indicated. Each such standard referred to shall be considered a part of the specifications to the same extent as if reproduced herein in full. The following is a list of applicable documents that apply to this contract.

American Association of State Highway and Transportation Officials (AASHTO) formerly (AASHO)

American Concrete Institute (ACI)

American Institute of Steel Construction (AISC)

American Iron and Steel Institute (AISI)

American National Standards Institute (ANSI)

American Standards Association (ASA)

American Society of Mechanical Engineers (ASME)

American Society of Testing and Materials (ASTM)

American Water Works Association (AWWA)

American Welding Society (AWS)

Anti-Friction Bearing Manufacturer's Association (AFBMA)

Building Officials and Code Administrators International, Inc. (BOCA)

Construction Specifications Institute (CSI)

Federal Specifications (FS)

Florida Building Code (FBC), 6th Edition (2017)

Florida Department of Transportation (FDOT) Standard Specifications for Road and Bridge Construction, 2019 Edition (Standard Specifications)

Florida Department of Traffic Design Standards Newest Edition (FDOT Index)

Jacksonville Electric Authority (JEA) Water and Sewer Specifications and Regulations (latest editions)

National Bureau of Standards (NBS)

National Electrical Manufacturer's Association (NEMA)

National Fire Protection Association (NFPA)

Portland Cement Association (PCA)

Occupational Safety and Health Act (Public Law 91-596), U.S. Department of Labor (OSHA)

Steel Structures Painting Council (SSPC)

Southern Standards Building Code (SSBC)

Underwriters' Laboratories, Inc. (UL)

United States of America Standards Institute (USASI)

Regulations of Florida Industrial Commission Regarding Safety

All local, state, county, or municipal building codes requirements of the Owner's Insurance

SECTION 01 22 50**MEASUREMENT AND PAYMENT****PART 1 GENERAL**

- 1.01 The Bidder shall receive and accept the compensation provided in the contract at the lump sum price, except as may be modified by change orders. The compensation provided for in the contract shall constitute full payment for furnishing all labor, equipment, tools, and materials and for performing all work contemplated and embraced under the contract; for all loss or damage arising out of the nature of the work or from the action of the elements; for all expenses incurred by, or in consequence of, the suspension or discontinuance of the said prosecution of the work or from any unforeseen difficulties or obstructions that may arise or be encountered during the prosecution of the work; and for all risks of every description connected with the prosecution of the work until the final acceptance of the work by the County.
- 1.02 Neither the payment of any progress payment nor of any retained percentage shall relieve the Bidder of any obligation to make good any defective work or material. Payment will be made only for materials actually incorporated in the work.

PART 2 SCHEDULE OF VALUES

- 2.01 If the Contract is based on a lump sum bid price or contains one or more lump sum items for which progress payments are to be made, the Bidder shall prepare and submit a detailed schedule of values covering each lump sum item to the County or Project Manager for approval. The detailed schedule of values shall show the estimate value of each kind or item of work, which will be used for estimating partial payment requests. The sum of the lump sum items listed in the breakdown estimates shall equal the contract lump sum. Overhead and profit shall not be listed as separate items.
- 2.02 The schedule of values shall be approved by the County or Project Manager before any progress payments are prepared. An unbalanced breakdown estimate providing for overpayment to the Bidder for items of work to be performed first will not be approved but shall be revised by the Bidder and resubmitted until acceptable to the County or Project Manager.
- 2.03 Adjustments to costs provided in the accepted Schedule of Values may be made only by Change Order.

- 2.04 The County reserves the right to delete any item included in the Schedule of Values and decrease the Contract Price by the scheduled amount for the item deleted.

SECTION 01 31 19

PROJECT MEETINGS

1.01 PRECONSTRUCTION CONFERENCE

- A. A preconstruction conference will be scheduled after award of contract and prior to beginning work. This meeting shall be attended by Engineer of Record, Project Manager, the County, and an authorized representative of Bidder.
- B. Meeting will consider matters of contract administration and initial construction operations.
- C. Bidder shall submit proposed construction schedule prior to or at preconstruction conference; see Section 01 33 00.

1.02 PROGRESS MEETINGS

- A. Periodic progress meetings will be held at a time and place mutually agreed upon at preconstruction conference. A responsible representative of Bidder who can bind Bidder/subcontractor to decisions shall attend. A responsible representative of other subcontractors working on site shall also attend.
- B. Meetings will be held to coordinate and expedite progress of work and shall be conducted by Bidder. Bidder and each subcontractor on site shall submit a written report at each meeting indicating:
 - 1. Work progress since last meeting.
 - 2. Upcoming work sequences and schedules.
 - 3. Requests for information.
- C. Bidder shall record meeting minutes and shall distribute a written summary of items discussed to all parties involved in the project within 48 hours of each meeting. The written summary shall document all issues discussed and decisions reached at progress meeting.

SECTION 01 33 00**SUBMITTAL PROCEDURES****1.01 SUMMARY**

- A. Submit items to County or Project Manager for review as listed below and as required by the other Contract Documents. Refer to individual specification sections, General Conditions, Supplementary Conditions, and sections of Division 01 - General Requirements for submittal requirements.

1.02 CONSTRUCTION SCHEDULE

- A. Prior to or at preconstruction conference, submit two copies of a proposed schedule of operations. Coordinate activities of the various trades for orderly completion of the work. Coordinate activities with those of the County to schedule a minimum of temporary disruptions to continuing operations. Allow ample time for the County to alter operations as required.
- B. After acceptance of construction schedule, distribute copies to subcontractors and other parties required to comply with scheduled dates.
- C. When revisions to schedule are made, notify all parties of changes in writing.

1.03 SCHEDULE OF SUBMITTALS

- A. Within 10 days of acceptance of construction schedule, submit two copies of a schedule of submittals. Schedule shall list anticipated date for each required submittal and shall allow County and/or Engineer of Record reasonable time for reviews. Submit all submittals requiring Engineer of Record review within 30 days of acceptance of construction schedule.
- B. After acceptance of schedule of submittals, distribute copies to subcontractors and other parties required to comply with submittal dates.

1.04 SHOP DRAWINGS

- A. Required shop drawings are designated under the various specification sections. Submit shop drawings for review prior to fabrication, delivery, or installation. Submit a minimum of five copies; two copies will be retained and the remainder returned to Bidder who shall keep one copy at project site.

- B. Fabrication and erection drawings may consist of a reproducible and two sets of prints; the reproducible copy will be returned to Bidder.
- C. Each brochure of shop drawings shall contain an index of contents and shall consist of layout details, schedules, setting instructions, manufacturer's literature, and other data specifically prepared for the work. Shop drawings shall be identified with project name, numbered consecutively, and bear the stamp of approval of Bidder as evidence of accuracy, compatibility, and conformance with contract requirements. Drawings not so stamped will be returned without being examined.
- D. Specific written notice shall be given of each variation that shop drawings may have from requirements of the Contract Documents.
- E. Partial submittals will not be considered; each portion of work shall be complete in one submittal.
- F. Shop drawings shall not be used in the work unless they have been reviewed and bear the stamp and signature of Engineer of Record. Shop drawings will only be reviewed for general conformance with the design concept of the project and general compliance with the information given in the Contract Documents. Bidder shall be responsible for confirming and correlating all quantities and dimensions, selecting fabrication processes and techniques of construction, coordinating his or her work with that of all other trades, and performing all work in a safe and satisfactory manner. Corrections or comments made on shop drawings shall not relieve Bidder from compliance with requirements of Drawings and Specifications and shall not be considered an order for extra work.
- G. If information on previously reviewed shop drawings is altered, submit changes for review.

1.05 PRODUCT DATA

- A. Required product data submittals are designated under the various specification sections. Submit product data for review in accordance with procedures for shop drawings.
- B. Product data shall consist of manufacturer's literature, illustrations, and brochures of catalog cuts; instructions for handling, storage, and installation;

and specifications and design data. Where multiple options are indicated, identify specific options as required for this project.

- C. Products subject to product data review shall not be used in the work until they have been reviewed and bear the stamp and signature of Engineer of Record.

1.06 SAMPLES

- A. Prior to fabrication, delivery, or installation, submit samples as designated in the various specification sections; allow reasonable time for review and testing.
- B. Submit samples in sufficient quantity and of adequate size to show quality, type, and extremes of color range, finish, and texture. Submit a minimum of two sets of appearance and color samples. Label each sample stating material, description, project name, and Bidder's name. Expedite submittal of appearance and color samples following Notice to Proceed.
- C. Submit samples with transmittal letter requesting review; prepay transportation charges. Samples shall become the County's property, unless otherwise designated.
- D. Samples will be reviewed for acceptability or selection of color, pattern, and texture only. Compliance with specifications is the responsibility of Bidder.
- E. Order no materials subject to sample review until receipt of written notice of completion of review. Installed materials shall match reviewed samples. No review of samples shall be taken in itself to change contract requirements.

1.07 CERTIFICATES OF COMPLIANCE

- A. Submit two copies of certificates of compliance as designated in the various specification sections.
- B. Certificates shall be furnished by manufacturer, producer, or supplier of material or product and shall indicate that material or product conforms to or exceeds specified requirements. Include supporting reference data as appropriate. Certificates may be recent or previous test results on material or product, but must be acceptable to the Project Manager and/or Engineer of Record.

1.08 PERMITS AND APPROVALS

- A. Submit one copy of permits, code inspections, and agency approval documents, as designated in the various specification sections.

1.09 TEST REPORTS

- A. Submit two copies of test reports as designated in the various technical specifications.

1.10 PROJECT RECORD DOCUMENTS

- A. Keep a current set of documents at job site that are marked to show all changes made during construction. Dimension underground and concealed work and utilities from permanent reference points; record vertical distances. Submit project record documents upon completion of Work.

SECTION 01 41 23**PERMITS AND FEES****PART 1 - GENERAL****1.01 DESCRIPTION**

- A. County Responsibilities: The County has obtained or will obtain the following permits, included in appendix:
- None
- B. Bidder responsibilities: Obtain and pay for all other permits and licenses required by authorities having jurisdiction, including but not limited to: land clearing permit, NPDES Notice of Intent and dewatering permit, right-of-way permits, etc.
- C. Bidder shall be responsible to adhere to all provisions, requirements, and cost contained in all permits applicable to this project.

PART 2 - PRODUCTS (NOT USED)**PART 3 - EXECUTION (NOT USED)**

SECTION 01 45 00**QUALITY CONTROL****PART 1 GENERAL****1.01 BIDDER QUALITY CONTROL PLAN**

The Bidder is responsible for his own quality control and must comply with Nassau County will act as the Department in all issues relating to Quality Control.

1.02 SECTION INCLUDES

Certification and testing, examination by the County, quality assurance testing, and final approval or work.

1.03 CERTIFICATION AND TESTING

The materials and equipment used in the construction of the project shall be subject to adequate certification and testing in accordance with generally accepted standards, as required and defined in the Contract Documents.

1.04 BIDDER TO PROVIDE

The Bidder shall provide all tools, testing apparatus, materials to be tested, and labor as necessary to provide certification required by the Contract Documents.

1.05 OUTSIDE AGENCY

If the Contract Documents, laws, ordinances, rules, regulation or orders of any public authority having jurisdiction require any work to be certified, tested, or approved by someone other than the County, the Bidder will give the Engineer of Record timely notice of readiness. The Bidder will then furnish the County the required certification and/or testing certificates for approval.

1.06 LIMIT OF APPROVALS

Certifications, tests, or approvals by the County, Engineer of Record, or others shall not relieve the Bidder from his obligations to perform the work in accordance with the requirements of the Contract Documents.

1.07 ACCESS TO WORK SITE

The County and Project Manager will at all times have access to the work. In addition, authorized representatives and agents of any participating federal or state agency shall be permitted access to all work, materials, payrolls, records of personnel, invoices of materials, and other relevant data and records. The Bidder will provide proper facilities for such access and observation of the work.

PART 2 EXAMINATION BY THE COUNTY

2.01 ACCESS

The County contemplates and the Bidder agrees to thorough examination of the work at all times by the County, the Engineer of Record and Project Manager, including all labor performed and materials furnished, delivered, or intended to be used in the work, including manufacture, preparation, and testing. The Bidder shall not use any material which has not been tested and accepted. The Bidder shall keep the Project Manager and/or Engineer of Record advised of the progress of the work away from the site requiring certification of witnessing of tests to ensure that scheduling conflicts or delays do not develop.

2.02 ACCEPTANCE TESTS

Tests, or acceptance of any materials prior to shipment, shall not be deemed as a final acceptance of the materials. The County may require tests or analysis of any portion of the materials at any time. Any material which is found to be defective or which does not otherwise conform to the requirements of the specifications shall be rejected and removed forthwith from the site, as provided in the contract.

2.03 RIGHT TO EXAMINE WORK

The County, the Engineer of Record and Project Manager shall have the right to examine all materials and work done during any phase of construction, fabrication, or manufacture. The Bidder shall furnish all reasonable facilities and aid to the Engineer of Record and/or Project Manager and safe and convenient means for the examination of any part of the work. No work shall be closed or covered until it has been duly examined and approved.

PART 3 QUALITY ASSURANCE TESTING

3.01 DESCRIPTION

The Bidder is required to provide all testing as described in these specifications. Testing shall be completed by an independent testing laboratory retained by the Bidder and approved by the Engineer of Record. The Bidder is required to submit independent testing laboratory qualifications. Certifications, tests, or approvals by the County, Engineer of Record, or others shall not relieve the Bidder from his obligations to perform the Work in accordance with the requirements of the Contract Documents.

3.02 CODES AND REGULATIONS TESTING

Testing will be in accordance with all pertinent codes and regulations and with selected standards of the American Society of Testing and Materials. The Engineer of Record shall process and distribute all required copies of test reports and related instruction to ensure all necessary retesting and/or replacement of materials with the least possible delay in progress of work.

3.03 RETESTING

When initial quality assurance tests indicate noncompliance with the Contract Documents, all subsequent retesting occasioned by the noncompliance shall be performed by the same testing laboratory and the costs thereof shall be borne by the Bidder.

3.04 COOPERATION WITH THE COUNTY'S TESTING LABORATORY

The County may perform any additional tests that he may deem necessary at his own expense. Representatives of the County's testing laboratory shall have access to the work at all times. The Bidder shall provide facilities for such access in order that the laboratory may properly perform its functions.

3.05 ADDITIONAL TESTING

If the County orders sampling, analysis, or tests of materials which are specified to be accepted on certification by the manufacturer, but which appear defective or not conforming to the requirements of the specifications, the Bidder shall bear all the costs of sampling, transportation, tests, and analyses if the material is in fact found defective or does not conform to the specifications. If the material is found to be sound and conforming to the specifications, the County will pay for the testing.

PART 4 FINAL APPROVAL**4.01 FINAL APPROVAL**

Final approval of the Work made by the County, the Engineer of Record and/or Project Manager, shall be contingent upon the findings of a thorough examination of the Work. Such examination shall be made within ten (10) working days after receipt of the Bidder's written request. The Work will be accepted and deemed completed as of the date of such examination if, upon such examination, the Engineer of Record and/or Project Manager and the County find that no further Work remains to be done at the site. If the examination reveals items of Work still to be performed, the Bidder shall promptly perform them and request a re-examination. If upon any reinspection the Engineer of Record and/or Project Manager and the County determine that the Work is complete, the date of completion shall be deemed to be the actual date of such re-examination.

SECTION 01 50 00**TEMPORARY FACILITIES AND CONTROLS****1.01 TEMPORARY ELECTRICITY**

- A. Bidder shall provide temporary electric service and distribution facilities as required for its own construction purposes. Provide portable power supply or make arrangements with local utility company for temporary service including service poles, driven ground, main service switch, transformer, and metering facilities. Pay for electrical energy consumed.

1.02 TEMPORARY LIGHTING

- A. Bidder shall provide temporary lighting sufficient to enable its workers to complete work and to enable inspectors to check work, as required.

1.03 TEMPORARY WATER

- A. Bidder shall be responsible for obtaining water for its needs. Pay cost of water used and meter rental, if applicable.

1.04 TEMPORARY SANITARY FACILITIES

- A. Bidder shall provide temporary outside toilets sufficient for its own workers.

1.05 TEMPORARY FIRE PROTECTION

- A. Bidder shall provide fire extinguishers and other fire protection equipment for all possible classes and types of fire.

1.06 PROTECTION OF WORK AND PROPERTY

- A. Observe safety provisions of applicable laws and regulations.
- B. Erect and maintain all required planking, barricades, guardrails, fences, safety lanterns, and temporary walkways of sufficient size, strength, and type necessary for protection of material storage, adjacent property, and new construction, as well as to prevent accidents to public and workers at job site.
- C. Notify the County and/or Project Manager if existing property interferes with work so that arrangements for proper protection can be made.

- D. Protect all work, materials, apparatus, and fixtures incorporated in work or stored on site against damage. At end of day, cover all new work likely to be damaged.
- E. Protect all finished construction until acceptance by the County. Repair damage to finished work to satisfaction of the County.

1.07 ENVIRONMENTAL CONTROLS

- A. Maintain erosion control measures to protect the project site and prevent sediment pollution of adjacent water courses and properties.
 - 1. Install erosion control measures prior to start of construction and maintain them until final completion of work. Unless otherwise instructed, remove temporary erosion control measures prior to final application for payment.
 - 2. Strive to limit stripping of sod and vegetation to a period that will expose bare soil to the least possibility of erosion that construction requirements allow.
 - 3. Construct and maintain silt fence barriers, erosion bale barriers, or temporary diversions to receive runoff leaving site.
 - 4. Protect storm drain inlets by using silt fence barriers, erosion bale barriers, or equivalent.
 - 5. Remove at the end of each work day soils and sediment reaching public or private streets not part of the construction site.
 - 6. Unless otherwise shown or specified, erosion control measures shall comply with the planning, design, and maintenance provisions of Section 104 of the Florida Department of Transportation Standard Specifications for Road and Bridge Construction, 2019 Edition and Index Nos. 102 and 103 in the 2014 Roadway and Traffic Design Standards Manual.
- B. Provide controls to confine dust and dirt within project area. Thoroughly soak masonry and debris during demolition and loading operations. Water exposed soils or aggregates as required to prevent windblown dust.
- C. Provide noise control measures to limit the amount of noise and prevent nuisance. Properly equip all equipment with mufflers. Limit construction activities generating significant noise to normal working hours.

1.08 TRAFFIC CONTROL

- A. Conduct operations to ensure minimum interference with streets, driveways, walks, and adjacent facilities not part of construction project.
- B. Do not close or obstruct streets, walks, or other occupied or used facilities without permission from authorities having jurisdiction. Provide alternate routes around closed or obstructed traffic ways if required by governing regulations.

1.09 CONSTRUCTION CLEANING

- A. Remove rubbish and debris from work area promptly upon its accumulation. Perform a broom cleaning of all appropriate surfaces weekly.
- B. Immediately clean-up spillages of oil, grease, or other liquids which could cause a slippery or otherwise hazardous situation or stain a finished surface.
- C. Form or scrap lumber shall have all nails withdrawn or bent over and shall be stacked, placed in trash bins, or removed from site.
- D. At completion of project, thoroughly clean, sweep, and wash work to remove foreign matter, spots, and soil from work and equipment under this contract. Remove temporary guards and protective coatings.

1.10 DISPOSAL

- A. All demolition and construction debris are to be removed from the site at the Bidder's Expense.
- B. Provide industrial type waste containers in number and size required or provide other acceptable methods of disposing of debris. Place containers at adequate locations to handle debris and have them emptied as required.
- C. No burning of rubbish or debris will be allowed at site.
- D. Store combustible waste in fire-resistive containers. Store hazardous wastes, such as caustics, acids, and harmful dusts, in appropriate covered containers. Dispose of wastes regularly.
- E. If a Bidder does not remove rubbish or clean work as specified above, the County reserves right to have work done by others at Bidder's expense.

SECTION 01 55 26**TRAFFIC CONTROL****PART 1 - GENERAL****1.01 DESCRIPTION**

- A. This Section covers procedures for developing and implementing traffic control and regulation measures and maintenance of traffic in and around the construction area to provide for safe and efficient protection and movement of vehicular and pedestrian traffic/through and adjacent to the construction site areas.

1.02 REFERENCE STANDARDS

- A. General
 - 1. Codes, specifications, and standards referred to by number or title shall form a part of this Specification to the extent required by the reference thereto. Latest revisions shall apply, unless otherwise shown or specified.
- B. Florida Department of Transportation (FDOT) Standards:
 - 1. USDOT Manual on Uniform Traffic Control Devices.
 - 2. FDOT Manual of Traffic Control and Safe Practices for Street and Highway Construction, Maintenance and Utility Operations.
 - 3. FDOT Standard Specifications for Road and Bridge Construction, 2019 Edition.

1.03 SUBMITTALS

- A. Before closing or restricting traffic flow through any thoroughfare, the Bidder shall give written notice to and, if necessary, obtain a permit or permits from the duly constituted public authority having jurisdiction over the thoroughfare. Bidder shall also notify the applicable law enforcement, fire, and emergency services having jurisdiction in the area. Notice shall be given no less than seventy-two (72) hours in advance of the time when it may be necessary in the

process of construction to close or restrict traffic to such thoroughfare, or as may be otherwise required by the governing authority.

- B. For any road or lane closures on this project, Bidder shall refer to the Nassau County Road Closure Policy and contact Nassau County Engineering Services Department at (904) 530-6225.

*****THERE WILL BE NO ROAD CLOSURES NEEDED FOR THIS PROJECT*****

1.04 SITE CONDITIONS

- A. The Bidder shall plan construction operations such that existing local traffic access can be maintained and shall be maintained during the construction using such barricades, lights, flagmen, and other protective devices as appropriate, whether specified for the project or required by the local governing authority. Traffic control devices and implementation used for maintenance of traffic shall comply with the FDOT Manuals.
- B. The Bidder shall conduct his work in such manner as not to unduly or unnecessarily restrict or impede normal traffic through the streets of the community. Insofar as it is practicable, excavated material and spoil banks shall not be located in such manner as to obstruct traffic. The traveled way of all roads shall be kept clear and unobstructed insofar as is possible and shall not be used for the storage of construction materials, equipment, supplies, or excavated earth, except when and where necessary. If required by duly constituted public authority, the Bidder shall, at his own expense, construct bridges or other temporary crossing structures over trenches so as not to unduly restrict traffic. Such structures shall be of adequate strength and proper construction and shall be maintained by the Bidder in such manner as not to constitute an undue traffic hazard. Private driveways shall not be closed except when and where necessary, and then only upon due advance notice to the County, property owner and applicable jurisdictional authority, and shall be for the shortest practicable period of time consistent with efficient and expeditious construction. The Bidder shall be liable for any damages to persons or property resulting from his work.
- C. The Bidder shall make provisions at cross streets for the free passage of vehicles and foot passengers, either by bridging or otherwise, and shall not obstruct the swales nor prevent in any manner the flow of water in the swales, but shall use all proper and necessary means to permit the free passage of surface water in the swales. The Bidder shall immediately cart away all offensive matter, exercising such precaution as may be directed by the County or applicable

jurisdictional authority. All material excavated shall be so disposed of as to inconvenience the public and adjacent tenants as little as possible and to prevent injury to trees, sidewalks, fences, and adjacent property of all kinds. The Bidder may be required to erect suitable barriers to prevent such inconvenience or injury.

- D. Unless otherwise required by the governing authority, maintenance of traffic in and around the construction zone shall conform to Section 102 of the FDOT Specification, and 600 Series Roadway Design Standards drawings of the FDOT Standards, as applicable.

PART 2 - PRODUCTS (NOT USED)

PART 3 - EXECUTION (NOT USED)

SECTION 01 60 00**PRODUCT REQUIREMENTS****1.01 PRODUCTS**

- A. Provide new, high quality products manufactured and conditioned for the particular application as recommended by manufacturer, unless otherwise noted. Transport, handle, store, and protect products as specified and in accordance with manufacturer's recommendations.

1.02 MANUFACTURER'S DIRECTIONS

- A. Wherever work is to be performed or products are to be installed in accordance with manufacturer's instructions, furnish copies of printed instructions before installation.

1.03 SOURCE OF PRODUCTS

- A. In order that ready availability of materials, parts, or components for repair, replacement, or expansion can be assured, original equipment and components shall be obtained where feasible from domestic sources which maintain a regular stock.

1.04 ACCEPTABLE MANUFACTURERS

- A. Products, materials, and equipment identified by reference to a manufacturer's name, catalog number, or model are identified for the purpose of establishing a standard of quality, type, and function. Products first named in specifications are depicted for general descriptive purposes only. Any other product, material, or equipment which will perform adequately the duties imposed by the general design will be considered for substitution in accordance with the provisions below.

1.05 OPTIONS AND CHANGES

- A. Wherever options consisting of two or more choices are permitted for any product, procedure, or method, Bidder may select any of the named alternatives.
- B. Changes and revisions to Contract Documents may be made by Change Order, Field Order, or other procedure authorized under the Contract Documents.

- C. All other revisions not defined as options or changes shall be treated as Substitutions. (Options and changes will not be treated as Substitutions.)

1.06 BID PHASE SUBSTITUTIONS

- A. Substitutions and alternatives proposed prior to the Bid Deadline shall be submitted in accordance with the Instructions to Bidders.

1.07 CONSTRUCTION PHASE SUBSTITUTIONS

- A. Substitutions proposed after Contract has been awarded shall be submitted for approval prior to their use. Consideration will be given only to proposed substitutions for those products named in the Contract Documents which are no longer available or cannot be provided within the Contract Time, or where standard products are no longer in conformance, or where the County's interests may be adversely affected.
- B. If substitutions are approved, Bidder assumes responsibility for any other changes in systems or for modifications required in other work to accommodate the substitution, regardless of approval of the substitution.
- C. Requests for substitution of alternate products shall be submitted with complete references to manufacturer's product identification and product data indicating composition, guarantee, availability, applicable standards or agency approvals met or exceeded, restrictions imposed on product, and manufacturer's recommended method of application or installation. Substitutions will be considered acceptable if the product will perform adequately the duties imposed by the general design and, in opinion of Engineer of Record, is of equal substance, quality, appearance, and function, unless the named item is necessary for interchangeability or if the named product has been demonstrated to be most cost-effective.

1.08 DEFECTIVE PRODUCTS

- A. All products which do not conform to specified requirements shall be considered defective and shall be removed from the Work. If in place, faulty materials shall be corrected or replaced to meet specified requirements.

1.09 TRANSPORTATION AND HANDLING

- A. Products shall be transported and handled in accordance with the Contract Documents and as defined below. Deliver in original packaging with manufacturer's brand, seals, and labels intact. Refer to individual sections of specifications for specific requirements.
- B. Arrange for product transportation as required for construction. Select means of transportation which will reasonably assure timely and safe arrival. Products shall be suitable for intended use upon arrival at project and shall be undamaged and free from defects.
- C. Select appropriate methods for handling products to preserve their integrity, quality, and function.

1.10 MATERIAL PROTECTION

- A. Protect materials in accordance with Section 01 50 00, specific requirements of individual sections of specifications, and according to manufacturer's recommendations.
- B. Provide and maintain watertight storage sheds with raised floors for storage of products that might be damaged by weather. Cement, lime, and other materials affected by moisture shall be stored on platforms.

1.11 STORAGE

- A. Confine storage of products to limits designated by the County. Do not bring products to site until needed for progress of work. Storage of products within buildings shall not exceed design capacity of structural system.
- B. The County assumes no responsibility for products stored on site. Bidder shall assume full responsibility for damage to stored products, except as covered by property insurance for the work under construction (see General and Supplementary Conditions).
- C. Bidder shall allot space to subcontractors for storage of products and erection of offices and tool sheds. Locate storage buildings, temporary sheds, and stockpiles to avoid interference with new and existing facilities; move sheds, storage platforms, and materials as necessary.
- D. Upon completion, restore areas disturbed by construction.

SECTION 01 71 23**FIELD ENGINEERING****PART 1 - GENERAL****1.01 SECTION INCLUDES**

- A. Provide field engineering service for project as indicated on Drawings and specified in this Section.

1.02 QUALIFICATIONS OF SURVEYOR OR ENGINEER

- A. Florida Registered Engineer or Land Surveyor.

1.03 SURVEY REFERENCE POINTS

- A. Existing basic horizontal and vertical control points are designated on Drawings. All elevations are based on the benchmarks shown on the plans. Establish all vertical and horizontal controls required for construction.
- B. Locate and protect control points prior to starting site work, and preserve permanent reference points during construction.
 - 1. Make no changes or relocations of such points without prior written notice to Engineer of Record and/or Project Manager and the County.
 - 2. Report to Engineer of Record and/or Project Manager and the County when any reference point is lost or destroyed, or requires relocation because of necessary changes in grades or locations.
 - 3. Require surveyor to replace control points which may be lost or destroyed. Establish replacements based on original survey control.
 - 4. Engineer of Record and/or Project Manager will identify existing control points and properly line corner stakes indicated on Drawings, as required.
 - 5. Elevations are based on the National Geodetic Vertical Datum of 1988.

1.04 PROJECT SURVEY REQUIREMENTS

- A. Establish a minimum of two (2) permanent bench marks on the project site, all referenced to data established by survey control points. Record locations, with horizontal and vertical data, on Project Record Documents.
- B. Establish lines and levels, locate and lay out, by instrument and similar appropriate means.
 - 1. Site improvements.
 - 2. Controlling lines and levels required for mechanical and electrical trades.
- C. Verify layouts by same methods from time to time.

1.05 RECORDS

- A. Maintain a complete, accurate log of control and survey work as it progresses.
- B. On completion of foundations and major site improvements, prepare a certified as-built survey showing finished dimensions, locations, angles and elevations of construction.
- C. Refer to Nassau County's As-Built Checklist.

1.06 SUBMITTALS

- A. Submit name and address of surveyor or professional engineer to Engineer of Record and/or Project Manager and the County.
- B. On request of Engineer of Record and/or Project Manager and the County, submit documentation to verify accuracy of field survey work.
- C. Submit certificate signed and sealed by a State of Florida Registered Engineer or Land Surveyor certifying that elevations and locations of improvements are in conformance with Contract Documents.

PART 2 - PRODUCTS (NOT USED)

PART 3 - EXECUTION (NOT USED)**SECTION 01 77 00****CLOSEOUT PROCEDURES****1.01 SUMMARY**

- A. Complete closeout procedures and final submissions as listed below and as required by the other Contract Documents. Refer to General Conditions regarding Substantial Completion, final completion, and final payment.

1.02 FACILITY START-UP

- A. Submit test reports before requesting certification of Substantial Completion.

1.03 SUBSTANTIAL COMPLETION

- A. Bidder shall notify the Project Manager when it considers the Work (or a portion of the Work which the County agrees to accept separately) to be substantially complete. Bidder's notice shall include a comprehensive list of items to be completed or corrected prior to final payment.
- B. Upon receipt of Bidder's list, Project Manager, the County, and Bidder shall make an inspection to verify that the Work is substantially complete.
 - 1. If the County considers the Work to be substantially complete, the County will issue a Certificate of Substantial Completion along with a "Construction Acceptance Checklist" of items to be completed or corrected prior to final payment. Items on punch list shall be completed within 60 days. Required submittals (see below) shall be completed prior to or when requesting final payment.
 - 2. If the County does not consider the work to be substantially complete, the County will inform Bidder of items that need to be completed or corrected before substantial completion. Bidder shall promptly complete these items and request a reinspection by the County.

1.04 FURNISHED PRODUCTS AND LOANED TOOLS

- A. Prior to final payment, return all extra materials, unused parts, and equipment furnished by the County; return loaned tools and equipment.

1.05 FINAL COMPLETION

- A. Bidder shall notify the Project Manager and the County when it considers all Work to be complete. Project Manager, the County, and Bidder shall make an inspection to verify that the Work is complete.
 - 1. If the County considers the Work to be complete, Bidder shall submit final Application for Payment.
 - 2. If the County does not consider the Work to be complete, the County will inform Bidder of items that need to be completed or corrected before completion. Bidder shall promptly complete these items and request a reinspection by the County.
- B. Prime Bidder is responsible for reviewing all Construction Acceptance Checklist items and verifying that each item is complete before requesting final inspection.

1.06 CHARGES FOR REINSPECTIONS

- A. The County will inspect the Work (or a portion of the Work which the County agrees to accept separately) at substantial completion and at final completion. If the Work is not complete to the required level at either substantial completion or final completion, and a reinspection is required, Bidder shall reimburse the County for charges of the County and the County's consultants for performing the reinspection.

1.07 SUBMITTALS

- A. Submittals required before Contract Closeout are listed below:
 - 1. Bidder Lien Waiver
 - 2. Subcontractor Lien Waiver
 - 3. Consent of Surety to Final Payment
 - 4. Compliance with all permits and other governmental agencies
 - 5. Certification of Inspections "Certification Package"
 - 6. Warranties and Bonds
 - 7. As-Built Drawings
 - 8. Operation and Maintenance Manuals
 - 9. All other documents as required in the Contract Documents

DIVISION 31

EARTHWORK

SECTION 31 05 10**SITE PREPARATION****PART 1 GENERAL****1.01 SUMMARY**

- A. Provide site preparation as shown and as specified. Comply with applicable provisions of Div. 00 and 01.
- B. Work includes, but is not limited to:
 - 1. Protection of improvements, plants, and utilities.
 - 2. Removal and replacement of improvements.
 - 3. Location of utilities and coordination with utility companies.
 - 4. All clearing and grubbing of trees and vegetation.
 - 5. Topsoil salvage.

1.02 MEASUREMENT AND PAYMENT

- A. Site preparation will be considered will be considered and priced as part of the Lump Sum bid.
- B. Drawing notes related to removals and replacements shall be interpreted as directives to Contractor for such work at no extra cost.

PART 2 (NOT USED)**PART 3 EXECUTION****3.01 PROTECTION**

- A. Protect improvements on site and on adjoining properties. Provide barricades, coverings, or other types of protection as necessary to prevent damage and to safeguard against injury. Restore to original condition improvements damaged by the work or improvements which required temporary removal during construction.
- B. Protect existing vegetation indicated to remain against unnecessary cutting, breaking, bruising, or smothering by stockpiling excavated materials or parking of vehicles within drip line. Provide temporary fences, tree wells, barricades, or

guards; repair or replace trees and vegetation damaged by construction operations.

- C. Protect survey monuments, reference points, and benchmarks from movement. Should removal be necessary, notify Engineer of Record and/or Project Manager and/or Project Manager and the County who will give notice for removal at Contractor's expense. Contractor shall pay cost for re-establishing monuments lost due to its negligence or failure to notify Engineer of Record and/or Project Manager and/or Project Manager and the County.
- D. No extra payment or time will be allowed for protection work that could have been suspected or anticipated by site inspection and interpretation of bidding documents prior to execution of contract.

3.02 UTILITIES

- A. Location and description of underground utilities and structures shown on drawings are approximate and are based on records available to the County or surface features indicating their existence. There may be other utilities within project area that are not shown.
- B. Notify all affected utility companies of construction operations at least three working days before beginning work near their facilities. Do not begin excavation work until underground utility locations have been marked.
- C. Use caution when excavating so that exact location of underground utilities, both known and unknown, may be determined. Provide adequate protection and support for utilities during construction operations.
- D. If uncharted or incorrectly charted utilities are encountered during excavation work, or if proposed construction conflicts with existing utilities, give prompt notice and submit proposed solution to Engineer of Record and/or Project Manager and/or Project Manager and the County for approval. If required, make arrangements with utility companies for relocation of interfering utilities. No extra cost or time will be allowed for unexpected delays or coordination work, except for authorized alterations as follows. When a change is permitted to avoid a utility relocation, Engineer of Record and/or Project Manager and/or Project Manager and the County will determine whether such change constitutes extra work. Underground utilities and structures located outside of construction limits which Contractor wishes to have moved to facilitate construction shall be arranged with each owner of such facilities; Contractor shall pay all costs of such relocations for convenience.

- E. During construction of pipe lines, it may be necessary to cross under certain underground utilities and structures. Prevent damage to such facilities. Where necessary, divert flow in drains or culverts so that trenches are kept dry during work. Deposit and compact sand or gravel bedding and backfill around exposed facilities by mechanical means in layers not to exceed 6 in. Wherever such facilities are disturbed or broken, restore them to good condition at no additional cost to the County.

3.03 SITE CLEARING

- A. Remove trees, stumps, snags, shrubs, brush, heavy growths of grass, weeds and other vegetation, improvements, rubbish and debris, and obstructions that interfere with proposed construction; remove items only as necessary for completion of work.
- B. Cut brush and vegetation flush with ground. Grub out stumps, roots having a diameter of 2 in. or larger, and root clusters to a depth of at least 2 ft below subgrade elevation for pavements, structures, and embankments and 6 in. below ground surface in other areas.
- C. Carefully and cleanly cut roots and branches of trees indicated to be left standing, where such roots and branches obstruct new construction. Cut back roots a minimum of 1 ft from concrete work, paving, and structures and to a depth of not less than 2 ft below structures, foundations, and embankments.

3.04 TOPSOIL STRIPPING

- A. Topsoil shall include all friable, fertile, loam soil suitable for grass and plants, found at surface to a depth of approximately 4 in., reasonably free of subsoil, clay lumps, stones, objects over 2-in. diameter, weeds, large roots, root clusters, and other objectionable material.
- B. Strip topsoil from project area to whatever depths encountered; prevent intermingling with underlying subsoil or other objectionable material. Remove heavy growths of grass from areas before stripping topsoil.
- C. Where trees are indicated to remain, terminate stripping a sufficient distance from such trees to prevent damage to root system.

- D. Stockpile topsoil in storage piles in areas where designated. Construct storage piles to freely drain surface water. Cover or sprinkle water on storage piles to prevent windblown dust.

3.05 DEMOLITION

- A. Remove structures, pavements, and improvements within construction limits as shown and as required for construction. Saw cut asphaltic and concrete pavement to provide a smooth straight joint. Remove below-grade items encountered, such as slabs and foundations, that interfere with construction.
- B. The County shall have first right to retain all useful salvage. All items not retained by the County and construction debris shall become property of Contractor.

3.06 DEBRIS DISPOSAL

- A. Remove debris and excess materials from site and legally dispose of it. Burning shall not be permitted on project site. Comply with federal, state, and local laws and regulations.

SECTION 31 20 00**EARTHWORK****PART 1 GENERAL****1.01 SUMMARY**

- A. Provide earthwork as shown and as specified. Comply with applicable provisions of Div. 0 and 1.
- B. Excavation and Embankment shall be constructed in accordance with Section 120 of the Florida Department of Transportation Standard Specifications for Road and Bridge, 2019 Edition, and the FDOT Design Standards, 2017-18 (Index 500 and 505).

1.02 RELATED SECTIONS

31 05 10 Site Preparation

1.03 CLASSIFICATION

- A. Excavation of materials encountered under this work will be unclassified without regard to type, difficulty to remove, or suitability for use in construction.

1.04 SUBMITTALS

- A. Test Reports: Submit reports for laboratory and field tests required under "Testing" article Test reports for footing, slab, and pavement subgrades shall be submitted prior to placing concrete or paving materials. Make submittals in accordance with Section 01 33 00.

1.05 TESTING

- A. Contractor shall arrange and pay for soil sampling and testing by a qualified testing agency, acceptable to the County and independent of Contractor. Test soil materials for suitability for intended purpose using standard, recognized procedures.
- B. Determine mechanical analysis, liquid and plastic limit, and moisture-density curve (ASTM D1557) for each type of soil encountered.

- C. During course of work, testing agency shall inspect and approve subgrades and fill layers before further construction work is performed on each layer Perform field density tests as follows:
1. Structure Slabs and Paved Areas: Perform at least one field density test on fill subgrade for every 300 LF of structure slab or paved area, but in no case less than three tests. In each compacted fill layer, perform at least one field density test for every 300 LF of overlaying structure slab or paved area, but in no case less than three tests. Testing criteria will include operation for paved widening and paved shoulders, but not both simultaneously.
 2. Utility Trench Backfill: Perform at least two field density tests in random compacted backfill layers for every 400 linear feet of trench under pavements and structures.
- D. If in opinion of Engineer of Record and/or Project Manager and/or Project Manager and the County, based on reports of testing agency and inspection, subgrade or fills which have been placed are below specified density, provide additional compaction and testing at no additional cost to the County.

1.06 PROTECTION

- A. Protect existing improvements, utilities, trees and shrubs, and reference marks in accordance with Section 31 05 10.

1.07 BLASTING

- A. Use of explosives is not permitted.

PART 2 PRODUCTS

2.01 SOIL MATERIALS, GENERAL

- A. Soil materials shall be free of organic matter, debris and other objectionable materials. Rock particles larger than maximum size specified shall be removed prior to placement of soil.
- B. Select existing material from required excavations may be used for fill or backfill if it meets the specified product requirements. If necessary, furnish additional approved material from suitable off-site sources.

2.02 GRANULAR FILL, BEDDING, AND BACKFILL

- A. Select soils to comply with AASHTO M-145 - Classification of Soils and Soil-Aggregate Mixtures for Highway Construction Purposes.

2.03 FILL AND BACKFILL

- A. Previously excavated soils, free of aggregate larger than 3 in., and suitable for intended purpose.

PART 3 EXECUTION**3.01 PREPARATION**

- A. Prepare site for work in accordance with Section 31 05 10. Layout and stake lines and grades as required to complete the work.

3.02 EXCAVATION

- A. Excavate to achieve necessary dimensions, lines, grades, and cross-sections. Conform to elevations and dimensions shown within a tolerance of plus or minus 0.10 ft.
- B. For footings and foundations, take care not to disturb bottom of excavation. Excavate to final grade just before concrete is placed. Trim bottoms to required lines and grades to leave solid, undisturbed base to receive granular fill, base course, or concrete as shown.

3.03 TRENCHING

- A. Excavate trenches so that pipe can be laid safely and accurately to required line and grade. Hand excavate for bells, fittings and projections to allow for proper jointing and to insure that pipe rests evenly along barrel and is not resting on bell.
- B. In sand and gravel soils, bottom of trench may be shaped to fit bottom 1/3 of pipe. In silt or clay soils, bottom of trench shall be 4 in. below pipe barrel and 3 in. below bell. Under foundations and footings, bottom of trench shall be 8 in. below pipe. Provide Granular Bedding as specified below.

3.04 UNAUTHORIZED EXCAVATION

- A. Unauthorized excavation consists of removal of materials beyond indicated elevations or side dimensions without specific direction of Engineer of Record and/or Project Manager and/or Project Manager. Unauthorized excavation, as well as remedial work, shall be at Contractor's expense. Notify Engineer of Record and/or Project Manager and/or Project Manager and the County if unauthorized excavations are made.
- B. Backfill and compact unauthorized excavations as specified for authorized excavations of same classification, unless otherwise directed.

3.05 ADDITIONAL EXCAVATION (OVER EXCAVATION)

- A. When excavation has reached required subgrade elevation, notify Engineer of Record and/or Project Manager and/or Project Manager and the County who will make an inspection of conditions. Inform Engineer of Record and/or Project Manager and/or Project Manager and the County of unsuitable, unconsolidated subgrade soils.
- B. If unsuitable bearing materials, such as poorly compacted fill, existing foundations, rubble, debris, or organic deposits, are encountered at required subgrade elevations, carry excavations deeper and replace excavated material with properly compacted Fill as directed by Engineer of Record and/or Project Manager and/or Project Manager and the County.
- C. Removal of unsuitable material and its replacement as directed will be paid for as extra work. Do not proceed with extra work until authorized by the County.

3.06 STABILITY OF EXCAVATIONS

- A. Maintain sides and slopes of excavations in a safe condition per OSHA guidelines until completion of backfilling. Slope sides of excavations to angle of repose of material excavated; otherwise, shore and brace where sloping is not possible either because of space restrictions or stability of material excavated. Comply with applicable codes and ordinances.

3.07 DEWATERING

- A. Perform earthwork in a manner to prevent surface water and ground water from flowing into excavations. Promptly remove water from excavations using pumps, sumps, and dewatering system components necessary to convey water away from excavations. If underground springs are encountered, notify Engineer

of Record and/or Project Manager and/or Project Manager and the County before proceeding.

- B. Dewatering may require a "Generic Permit for the Discharge of Produced Groundwater from Any Non-Contaminated Site Activity." Groundwater testing may be required. The cost of any dewatering permit and required testing shall be paid by the Contractor.

3.08 STOCKPILING

- A. Stockpile excavated materials meeting the requirements for fill and backfill where directed until required for the work. Place, grade, and shape stockpiles for proper drainage. Locate stockpiles a sufficient distance from edge of excavations to prevent such material from falling or sliding into excavations and to prevent cave-ins.

3.09 COLD WEATHER PROTECTION

- A. Protect excavation bottoms against freezing when atmospheric temperature is less than 35 degrees F by covering with dry insulating materials of sufficient depth to prevent frost penetration.

3.10 EXAMINATION OF SUBGRADE

- A. Examine subgrade prior to placement of fill or backfill. Do not place materials on frozen subgrade. Plow, strip, or break-up sloped surfaces steeper than 1 vertical to 4 horizontal so that material will bond with subgrade. When subgrade has a density less than that specified for the particular area, breakup ground surface, pulverize, moisture-condition to optimum content, and compact top 12 in. to density specified in Part 4 Schedules.

3.11 FILLING AND BACKFILLING, GENERAL

- A. Do not place fill or backfill until required excavation and subgrade preparation have been inspected and approved by Engineer of Record and/or Project Manager and the County.
- B. Place fill or backfill in approximately horizontal layers; do not exceed the maximum lift thickness specified in Part 4 Schedules before compaction. Spread piles and windrows uniformly.

- C. Adjacent to structures, place fill or backfill to prevent damage and allow structures to assume loads gradually and uniformly, at approximately the same rate on all sides of structure.

3.12 TRENCH BEDDING AND BACKFILL

- A. Bedding, haunching, and initial backfill for rigid pipes shall be in accordance with ASTM C12, Class C or better. Bedding, haunching, and initial backfill for flexible pipes shall be in accordance with ASTM D2321, Class II or better.
- B. Trenches dug in sandy or gravelly materials may use undisturbed earth for bedding provided surface is shaped to conform to pipe. Provide Granular Bedding in all other trenches from subgrade to a point supporting bottom 1/3 of pipe for rigid pipe and to springline (mid-height) for flexible pipe. Place and compact bedding so that it fills and supports pipe haunch area.
- A. Immediately after installation of pipe, provide tamped Granular Backfill up to a minimum depth of 1 ft above pipe. Take special care in placing and tamping initial backfill material so alignment and grade of pipe is not disturbed nor pipe damaged.

3.13 BACKFILL

- A. Provide Backfill material to bring excavations to natural or designated grade.

3.14 GRADING

- A. Grade area within project limits by cutting and/or filling as necessary to achieve lines and grades shown. Grade areas adjacent to structure lines to drain away from structure to prevent ponding. Finish surface to be reasonably smooth and free from irregular surface changes. Tolerance for areas to receive topsoil shall be 0.3 ft above or below established grade, less allowance for topsoil. Tolerance for areas to be paved shall be 0.1 ft above or below established pavement subgrade.

3.15 COMPACTION

- A. Compact each layer of soil material to not less than the percentage of maximum density specified in Part 4 Schedules.
- B. Provide compaction equipment required to obtain specified compaction. Compaction by travel of grading equipment is not considered adequate for uniform compaction. Small vibratory compactors are required wherever fill is

placed adjacent to foundation walls, footings, and piers. Pipe bedding and initial backfill shall be hand or mechanically tamped.

- C. During placement and compaction, maintain moisture content of materials within optimum range.

3.16 DISPOSAL OF EXCESS AND WASTE MATERIALS

- A. Remove excess excavated material, trash, debris, and other waste materials and legally dispose of them off-site.

PART 4 SCHEDULES

4.01 COMPACTION SCHEDULE

| <u>Location</u> | <u>Lift Thickness¹</u> | <u>Compaction²</u> |
|---|-----------------------------------|-------------------------------|
| Below foundations, slabs, pavements, walks, and other designated areas. | 12" | 98% |
| Bedding and initial backfill around pipe and conduit. | 6" | 98% |
| Unpaved areas 10 ft. or less outside structure line. | 12" | 98% |
| Unpaved areas more than 10 ft. outside pavement area. | 12" | 95% |

¹Place manually compacted materials in maximum 6-in. layers.

²Percent of maximum density determined in accordance with AASHTO Modified Proctor T 188.

SECTION 31 22 00**SITE GRADING****PART 1 GENERAL****1.01 SUMMARY**

- A. Provide site grading, including preparation of subgrade for pavements and walks, as shown and as specified. Comply with applicable provisions of Div. 00 and 01.

1.02 RELATED SECTIONS

31 05 10 Site Preparation
31 20 00 Earthwork

1.03 CLASSIFICATION

- A. Excavation of materials encountered under this work will be unclassified without regard to type, difficulty to remove, or suitability for use in construction.

1.04 SUBMITTALS

- A. Test Reports: Submit reports for laboratory and field tests required under "Testing" article. Test reports for slab and pavement subgrades shall be submitted prior to placing concrete or paving materials. Make submittals in accordance with Section 01 33 00.
- B. Samples: Two weeks prior to start of construction, indicate source and submit samples of proposed fill and backfill materials for testing and review. Make submittals in accordance with Section 01 33 00.

1.05 TESTING

- A. Contractor shall arrange and pay for soil sampling and testing by a qualified testing agency, acceptable to the County and independent of Contractor. Test soil materials for suitability for intended purpose.
- B. Test subgrade and fill materials for gradation in accordance with ASTM C136 for conformance with AASHTO M-145 gradation limits. Test materials for liquid limit

and plasticity index in accordance with ASTM D4318. Analyze materials within 4 ft of finished grades of paved areas.

- C. Provide one optimum moisture-maximum density curve for each type of soil encountered in subgrade and fills under structure slabs and foundations and paved areas; determine maximum densities in accordance with ASTM D1557.
- D. During course of work, testing agency shall inspect and approve subgrades and fill layers before further construction work is performed on each layer. Perform field density tests in accordance with standard, recognized procedures. Take tests as follows:
 - 1. Structure Slabs: Perform at least one field density test on fill subgrade for every 300 LF of structure slab, but in no case less than three tests. In each compacted fill layer, perform at least one field density test for every 300 LF of overlying structure slab, but in no case less than three tests.
 - 2. Paved Areas: Perform at least one field density test on fill subgrade for every 300 LF of paved area, but in no case less than three tests. In each compacted fill layer, perform one field density test for every 300 LF of paved area, but in no case less than three tests.
- E. If in opinion of Engineer of Record and/or Project Manager and the County, based on reports of testing agency and inspection, subgrade or fills which have been placed are below specified density, provide additional compaction and testing at no additional cost to the County.

1.06 PROTECTION

- A. Protect existing improvements, utilities, trees and shrubs, and reference marks in accordance with Section 31 05 10.

PART 2 PRODUCTS

2.01 SOIL MATERIALS, GENERAL

- A. Soil materials shall be free of organic matter, debris and other objectionable materials. Rock particles larger than maximum size specified shall be removed prior to placement of soil.

- B. Select existing material from required excavations may be used for fill or backfill if it meets the specified product requirements. If necessary, furnish additional approved material from suitable off-site sources.

2.02 STRUCTURAL FILL

- A. Select soils complying with AASHTO M-145 soil classification system groups A-1-a, A-1-b, or A-3; or these groups in combination with group A-2-4. Maximum aggregate size shall be 1/2 specified lift thickness. Maximum 15% by weight shall pass a No. 200 sieve; plasticity index shall not exceed 5. Refer to FDOT Standard Index 2014 and Florida Department of Transportation Standard Specifications for Road and Bridge Construction, 2013 Edition.

2.03 SITE FILL

- A. Select, natural, free draining soils complying with AASHTO M-145 soil classification system groups A-1-a, A-1-b, A-3, or combinations thereof, and suitable for compaction. Maximum aggregate size shall be 1/2 specified lift thickness.

PART 3 EXECUTION

3.01 GRADING

- A. Grade area within project limits by cutting and filling as necessary to achieve new lines and grades shown.
- B. For lawn areas, allow 4 in. for topsoil placement. For landscape plants, allow 6 in. for topsoil placement. For surfaced areas such as slabs, pavements, and walks, grade to underside of respective surfacing or base course.
- C. Grade excavated and filled sections and adjacent transition areas to be reasonably smooth, compacted, and free from irregular surface changes. Degree of finish shall be that ordinarily obtained from either blade grader or scraper operations, except as otherwise specified. Tolerance for areas to receive topsoil shall be 0.3 ft above or below established grade, less allowance for topsoil. Tolerance for areas to receive surfacing shall be 0.1 ft above or below established subgrade.

3.02 SUBGRADE PREPARATION

- A. Examine subgrade prior to placement of fill. Remove any organic materials or debris subject to rot or corrosion. Plow, strip, or break-up sloped surfaces steeper than 1 vertical to 4 horizontal so that fill material will bond with subgrade.
- B. In structure areas, compact exposed subgrade in-place to the density specified in Part 4 Schedules by several passes of a large vibratory roller traveling at a relatively slow rate.
- C. In pavement areas, proofroll exposed subgrade with a loaded, tandem axle dump truck to detect soft or yielding areas.
- D. Notify Engineer of Record and/or Project Manager and the County of unsuitable, unconsolidated subgrade soils.

3.03 FILLING

- A. Provide Structural Fill under structure slabs, pavements, and walks. Provide Site Fill in unpaved areas.
- B. Place fill in approximately horizontal layers, do not exceed maximum lift thickness specified in Part 4 Schedules before compaction.
- C. During placement and compaction, maintain moisture content of materials within optimum range. Compact each layer of fill to not less than the percentage of maximum density specified in Part 4 Schedules.

3.04 MAINTENANCE

- A. Protect newly graded areas from traffic and erosion, and keep free of trash and debris. Repair and re-establish grades in settled, eroded, and rutted areas to specified tolerances.
- B. Maintain erosion control measures to prevent run-off and sediment pollution of adjacent water courses.

3.05 DISPOSAL OF EXCESS AND WASTE MATERIALS

- A. Remove excess excavated material, trash, debris, and other waste materials and legally dispose of them off-site.

PART 4 SCHEDULES**4.01 COMPACTION SCHEDULE**

| <u>Location</u> | <u>Lift Thickness</u> | <u>Compaction¹</u> |
|--|-----------------------|-------------------------------|
| Structure Slab, Pavement, and Walk Areas | See Section | 31 20 00 |
| Structure Slabs | 12" | 98% |
| Pavement and Walk Areas | 12" | 98% |
| Unpaved Areas (10' from EOP) | 12" | 95% |

¹Percent of maximum density determined in accordance with AASHTO Modified Proctor T 188.

SECTION 31 23 31**EXCAVATION FOR STRUCTURES AND PIPE****PART 1 GENERAL****1.01 SUMMARY**

- A. Excavation for structures and pipe shall be in accordance with Section 125 of the Florida Department of Transportation Standard Specifications for Road and Bridge Construction, 2019 Edition.

1.02 FOUNDATION PREPARATION

- A. The Contractor shall excavate at least two feet of clayey soils below manhole bases and one foot below pipeline inverts, if needed, and replace and compact with structural backfill to final bearing elevation. Compacted structural fill should then be placed around and above structures and pipelines to final grade. Compaction shall be in accordance with Section 120 of the Florida Department of Transportation Standard Specifications for Road and Bridge Construction, 2019 Edition.
- B. The Contractor shall maintain a dewatering system, if necessary, to sufficiently lower the water table in these areas at least 2 feet below the proposed depth of excavation. The dewatering system should not be decommissioned until sufficient deadweight exists on the structures to prevent uplift.

SECTION 31 23 33**TRENCHING AND BACKFILLING****PART 1 GENERAL****1.01 SUMMARY**

- A. Provide trenching and backfilling for piping, conduits, and other buried utilities as shown and as specified. Comply with applicable provisions of Divisions 00 and 01.

1.02 RELATED SECTIONS

31 05 10 Site Preparation.

1.03 CLASSIFICATION

- A. Excavation of materials encountered under this work will be unclassified without regard to type, difficulty to remove, or suitability for use in construction.

1.04 SUBMITTALS

- A. Test Reports: Submit reports for laboratory tests and field density tests required under "Testing" article. Make submittals in accordance with Section 01 01 00 and Section 01 33 00.

1.05 TESTING

- A. Contractor shall arrange and pay for soil sampling and testing by a qualified testing agency, acceptable to the County and independent of Contractor. Test soil materials for suitability for intended purpose using standard, recognized procedures. Determine mechanical analysis, liquid and plastic limit, and moisture-density curve (ASTM D698) for each type of soil encountered.
- B. Perform at least two field density tests in random compacted backfill layers for every 400 linear feet of trench, or fraction thereof, under roadways and walks. Density tests shall be at randomly selected locations and in accordance with ASTM D1556 (sand cone method) or ASTM D2922 (nuclear method). Where field testing indicates that soils are below specified density, provide additional compaction and testing at no additional cost to the County.

1.06 PROTECTION

- A. Protect existing improvements, utilities, trees and shrubs, and reference marks in accordance with Section 31 05 10.

1.07 MEASUREMENT AND PAYMENT

- A. Trenching, backfilling, and compacting work specified under this Section, including removing and disposing of obstructions, repairing or replacing damaged items, dewatering, and related construction delays, shall be considered incidental to bid items, and is included in Lump Sum Bid.

PART 2 PRODUCTS**2.01 SOIL MATERIALS, GENERAL**

- A. Soil for fill and backfill shall be free of organic matter, debris and other objectionable materials. Rock particles larger than maximum size specified shall be removed prior to placement of soil.
- B. Select existing material excavated from site may be used if it meets requirements specified. If necessary, furnish additional approved material from suitable off-site sources.

2.02 WASHED OR CRUSHED STONE

- A. Clean, hard, tough, durable, 1-1/2 in. washed stone, crushed rock, crushed gravel, or gravel free from adherent coatings and soft, flat, or elongated particles.

2.03 GRANULAR BASE, BEDDING, AND BACKFILL

- A. Soils complying with AASHTO M-145 soil classification system groups A-1-a, A-1-b or A-3. Aggregate shall pass a 1-1/2-in. sieve and not more than 35% shall be retained on a No. 10 sieve. Maximum 15% by weight shall pass a No. 200 sieve.

2.04 STRUCTURAL BACKFILL

- A. Select soils complying with AASHTO M-145 soil classification system groups A-1-a, A-1-b, or A-3; or these groups in combination with group A-2-4. Maximum aggregate size shall be 1/2 specified lift thickness. Maximum 15% by weight

shall pass a No. 200 sieve; plasticity index shall not exceed 5. Refer to FDOT Standard Index 2014 and Florida Department of Transportation Standard Specifications for Road and Bridge Construction, 2013 Edition.

2.05 BACKFILL

- A. Previously excavated soils, free of aggregate larger than 3 in., and suitable for intended purpose.

PART 3 EXECUTION

3.01 PREPARATION

- A. Provide site preparation, including clearing and topsoil removal, as required in accordance with Section 31 05 10.

3.02 TRENCHING

- A. Excavate trenches so that pipe can be laid safely and accurately to required line and grade. Hand excavate for bells, fittings and projections to allow for proper jointing and to insure that pipe rests evenly along barrel and is not resting on bell.
- B. Excavation shall extend to bottom of pipe bedding. Unnecessary excavation below this required level shall be filled with compacted sand, gravel, crushed stone or concrete, as approved by Engineer of Record and/or Project Manager and the County.
- C. In sand and gravel soils, bottom of trench may be shaped to fit bottom 1/3 of pipe. In silt or clay soils, bottom of trench shall be 4 in. below pipe barrel and 3 in. below bell. In rock, bottom of trench shall be 6 in. below pipe barrel. Under foundations and footings, bottom of trench shall be 8 in. below pipe Provide Granular Bedding as specified below.
- D. Trench widths in ordinary soil shall be limited at top of pipe to not less than a 24 in. clearance on either side of barrel to allow for installation of bedding material between pipe and trench wall. Maximum trench width at top of pipe shall be outside pipe diameter plus 24 in. (30 in. minimum). Trench above top of pipe may be sloped, stepped or vertical to comply with state and federal regulations regarding trenches.

- E. Minimum trench width in rock shall not be less than that for ordinary soil. Maximum trench width shall be outside pipe diameter plus 18 in. for an unsheathed trench, and outside pipe diameter plus 24 in. for sheathed trench.

3.03 STABILITY OF TRENCHES

- A. Slope sides of trenches to angle of repose of material excavated, otherwise, provide sheathing and bracing where sloping is not possible either because of space restrictions or stability of material excavated. Comply with applicable codes and ordinances.
- B. Maintain sides and slopes of trenches in a safe condition until completion of backfilling. Take precautions to prevent slides or cave-ins when trenches are made in locations adjacent to backfilled trenches, and when sides of trenches are subjected to vibrations from traffic, machinery, or any other source.

3.04 SHEATHING AND BRACING

- A. Provide tight sheathing where necessary to protect nearby structures and pavements, or when trench size must be confined. Notify Engineer of Record and/or Project Manager of unforeseen condition that requires use of sheathing. Sheathing shall be driven unless soil conditions allow sets to be placed after excavating. If placed after excavating, voids between trench wall and sheathing shall be immediately filled with sand.
- B. Removal of sheathing shall not take place until trench is backfilled. Compact backfill by flooding or jetting after sheathing is removed. Obtain written approval to leave some or all of sheathed sets to remain in place; cut off and remove upper portion within 2 ft of surface.

3.05 LIMITS OF AMOUNT OF WORK OPENED

- A. Do not open trenches more than 200 ft in advance of pipe laying unless otherwise permitted by Engineer of Record and/or Project Manager and the County; backfilling shall be kept within 600 ft of completed pipe laying Provide construction fence barricades around open trenches and pits when unattended.
- B. Trenches adjacent to roadways in service shall be backfilled to existing grade at completion of each day's work. Trenches elsewhere shall be backfilled each evening to within 50 ft of complete pipe installation.

- C. Maintain access to commercial enterprises at all times. Intersecting streets, private drives, and alleys shall be open to traffic at end of each day, unless otherwise approved.

3.06 WET TRENCH CONDITIONS

- A. Contractor shall attempt to dispose of ground water or surface drainage entering trench by employing ordinary dewatering techniques such as use of sump pumps, sump pits adjacent to pipe alignment, dikes, and similar methods. Dispose of or divert water along existing drainage ways. Do not place water so that it ponds on roadway subgrade or adjacent private property.
- B. Allowing water to flow into pipe being laid will not be permitted, except for storm sewer after joints have set. Install temporary stopper or plug on upper end of pipe if there is danger of sand or debris being washed into pipe.

3.07 UNSTABLE TRENCH BOTTOM

- A. When trench bottom is unstable because of ground water, Engineer of Record and/or Project Manager and the County may require extra excavation to remove unstable material. Provide Washed or Crushed Stone foundation followed by Granular Bedding as required in "Bedding and Initial Backfill" article.

3.08 POOR SUBSOIL MATERIALS

- A. Notify Engineer of Record and/or Project Manager and the County whenever muck, sawdust, bark, or other material is encountered which would not form a suitable and permanent base; Engineer of Record and/or Project Manager and the County may order it removed and replaced with Granular Base up to bottom of normal trench section.

3.09 BEDDING AND INITIAL BACKFILL

- A. Bedding, haunching, and initial backfill for rigid pipes shall be in accordance with ASTM C12, Class C or better. Bedding, haunching, and initial backfill for flexible pipes shall be in accordance with ASTM D2321, Class II or better.
- B. Trenches dug in sandy or gravelly materials may use undisturbed earth for bedding provided surface is shaped to conform to pipe. Provide Granular Bedding in all other trenches from subgrade to a point supporting bottom 1/3 of pipe for rigid pipe and to springline (mid-height) for flexible pipe; see Details. Place and compact bedding so that it fills and supports pipe haunch area.

- C. Immediately after installation of pipe, provide tamped Granular Backfill up to a minimum depth of 1 ft above pipe. Take special care in placing and tamping initial backfill material so alignment and grade of pipe is not disturbed nor pipe damaged.

3.10 TRENCH BACKFILL

- A. Backfill more than 1 ft over pipe under roadways and walks shall be Structural Backfill. All other trench backfill over initial backfill zone may be previously excavated soil subject to approval by Engineer of Record and/or Project Manager and the County.
- B. Backfilling above initial backfill zone in areas where settlement is not critical may be done from top of trench by mechanical means. In no case shall backfill material be dropped from such a height or in such a volume that its impact will cause dislocation or damage to piping.
- C. When backfilling in freezing temperatures, cover pipe and tamp backfill around pipe using only loose thawed material. Do not place frozen material in trench within 2 ft of top of pipe, nor around manholes and other structures.

3.11 COMPACTION

- A. Provide compaction equipment required to obtain specified compaction. Compaction shall be by mechanical means, except bedding and initial backfill may be hand or mechanically tamped. Compact each layer of soil material to not less than the density specified in Part 4 Schedules.

3.12 RESTORATION

- A. Unless otherwise specified, restore surface drainage, pavements, lawns, and other areas disturbed by construction to their original conditions. Areas adjacent to roadway shall be sloped to drain.

3.13 DISPOSAL OF EXCESS AND WASTE MATERIALS

- A. If directed by the County, deliver excess excavated materials to designated areas within a 20 mile radius of point of loading. Dispose of excess excavated materials not wanted by the County and waste materials at legal disposal site.

PART 4 SCHEDULES

4.01 COMPACTION SCHEDULE

| <u>Material Type</u> | <u>Usage</u> | <u>Lift Thickness</u> | <u>Compaction¹</u> |
|----------------------------|---|---------------------------|-------------------------------|
| Washed or Crushed Stone | Unstable trench bottom | 6" | 98% |
| Granular Base | Over excavation | 6" | 98% |
| Granular Bedding | Bedding and haunching | 6" | 98% |
| Granular Backfill | Initial backfill | 6" | 98% |
| Structural Backfill | Trench backfill under roadways and walks | 6" | 98% |
| Backfill | Trench backfill 10' from under roadways and walks | 12" | 95% |

¹Percent of maximum density determined in accordance with ASTM D698 or AASHTO Modified Proctor T 188.

SECTION 31 25 00**EROSION AND SEDIMENTATION CONTROL****PART 1 - GENERAL****1.01 DESCRIPTION**

- A. In addition to the requirements of the applicable sections in Divisions 00 and 01:
1. The provisions for prevention, control and abatement of erosion, sedimentation and water pollution shall be as stated in the FDOT Standard Specifications for Road and Bridge Construction, Section 104, 2013 (as modified in this document below), and as required by the St. John's River Water Management District.

1.02 CHANGES TO FDOT STANDARD SPECIFICATION 104

SECTION 104 (Pages 124 - 131) is deleted and the following substituted:

SECTION 104

PREVENTION, CONTROL, AND ABATEMENT OF EROSION AND WATER POLLUTION

104-1 Description

Provide an erosion and sediment control plan signed and sealed by a Specialty Engineer. Select and install temporary erosion and sediment control features in accordance with the plan for the project and for areas outside the right-of-way where work is accomplished in conjunction with the project and the project permits to prevent pollution of water and wetlands, detrimental effects to public or private property adjacent to the project right-of-way and damage to work on the project. Adjust, maintain, replace, or supplement selected devices as needed to ensure continuous control of erosion, sediment, turbid discharge, water pollution, and compliance with permit conditions until Final Acceptance in accordance with 5-11.

104-2 Features.

Use features identified as Best Management Practices (BMPs) in the State of Florida Erosion and Sediment Control Designer and Reviewer Manual and accepted by the Engineer. The Engineer will base acceptance on visual inspection, review of pertinent toxicity data and BMPs. Products containing geotextile fabric must meet the testing requirements in 985-4. The Engineer may also approve reuse of erosion and sediment control features, provided those features will not be incorporated into the completed project.

104-3 Preconstruction.

Provide an erosion and sediment control plan prepared by a Specialty Engineer in accordance with BMPs identified in the State of Florida Erosion and Sediment Control Designer and Reviewer Manual. At the preconstruction conference, submit the plan to the Engineer for review, discuss the plan, and review the requirements and special conditions of all permits. As a minimum, include the following items or activities in the plan:

- (1) For each phase of construction operations or activities provide:
 - (a) Locations of features
 - (b) Types of features
 - (c) Estimated time features will be in operation
 - (d) Monitoring schedules for maintenance of features
 - (e) Methods of maintaining features
 - (f) Methods of containing or removing pollutants or hazardous wastes
 - (g) limitations of exposed erodible earth as defined in 104-4.1
 - (h) Existing and proposed drainage and flow patterns
 - (i) Positive drainage measures to be employed, installing as soon as practical permanent drainage features
- (2) A procedure to control off-site tracking of soil by vehicles and construction equipment.
- (3) A procedure for cleanup and reporting of non-stormwater discharges such as contaminated groundwater or accidental spills.
- (4) The name and telephone number and copy of inspection qualifications for the person responsible for monitoring and maintaining the features.

Submit the project specific erosion and sediment control plan to the appropriate Water Management District for review and approval. Do not begin any construction activities until all approvals are received.

Prior to submitting a Notice of Intent (NOI) to the Florida Department of Environmental Protection (FDEP) to be covered under the FDEP Generic Permit for Stormwater Discharge from Large and Small Construction Activities (CGP), the Contractor's erosion and sediment control plan shall be incorporated into the Department's Stormwater Pollution Prevention Plan (SWPPP). Do not begin any soil disturbing activities until notification of permit coverage is received.

104-4 Construction.

104-4.1 General: Select and install temporary erosion and sediment control features in accordance with the sediment and erosion control plan. Adjust, maintain, replace, or supplement selected features as needed to ensure continuous control of erosion, sediment or turbid discharge and water pollution.

104-4.2 Erodible Earth Limits: Do not expose more than 750,000 ft² of erodible earth, unless otherwise approved by the Engineer. This limitation applies separately to clearing and grubbing operations and excavation and filling operations.

104-4.3 Field Reviews: The Specialty Engineer shall perform field reviews in conjunction with successive operations to verify implementation of the erosion and sediment control plan. Based on the field review, the Specialty Engineer shall provide additions or corrections to the copy of the sediment and erosion control plan kept at the project site and provide the Engineer with 2 copies of the changes.

104-4.4 Control of Operations: Install erosion and sediment control features prior to any soil disturbing operations commencing unless otherwise noted in the permits.

Prevent pollution of surface waters and wetlands including streams, canals, lakes, reservoirs, and other water impoundments with fuels, oils, bitumens, calcium chloride, sediment, turbidity, or other harmful materials. Also, conduct and schedule operations to avoid pollution or siltation of such water impoundments, and to avoid interference with movement of migratory fish. Do not dump any residue from dust collectors or washers into any surface waters.

Onsite fuel storage tanks and any equipment and material storage or maintenance areas within Department right of way must be maintained and stored in compliance with regulatory agency standards.

Locate temporary sanitary provisions away from inlets, streams, canals, lakes, reservoirs, and other water impoundments.

Restrict construction operations to those conditions allowed by permit in surface waters and wetlands such as rivers, streams, lakes, tidal waters, reservoirs, canals, and other water impoundments to those areas where it is necessary to perform filling or excavation to accomplish the work shown in the plans and permits and to those areas which must be entered to construct temporary or permanent structures using contained or stable materials. As soon as conditions permit, promptly clear rivers, streams, and impoundments of all obstructions placed therein or caused by construction operations back to preconstruction condition. Stabilize exposed areas as required by permit or within seven days, whichever is earlier.

Do not ford any surface waters with construction equipment. Wherever crossings are necessary, use a temporary bridge or other structure.

Except as necessary for construction and unless permitted by regulatory agencies, do not deposit excavated material or other erodable material in areas subject to concentrated flow of stormwater or in surface waters or wetlands such as rivers, streams, canals, or impoundments, or in a position close enough thereto, to be washed away by high water or runoff.

Where pumps are used to remove highly turbid waters from enclosed construction areas such as cofferdams or forms or from trench excavations, treat the water with methods outlined in the Manual to bring it into compliance with water quality standards acceptable to regulatory agencies prior to discharge into State waters. Do not allow discharged water to flow across unstabilized areas prior to entering surface waters or wetlands, and do not allow discharged waters to scour sediments and create turbidity in surface waters or wetlands.

Do not disturb lands or waters outside the limits of construction as staked, except as authorized by the Engineer.

Obtain the Engineer's approval for the location of, and method of operation in, borrow pits, material pits, and disposal areas furnished for waste material from the project (other than commercially operated sources) such that erosion during and after completion of the work will not result in detrimental siltation or water pollution in accordance with 7-1.

104-4.5 Erosion and Sediment Control Methods: Each of the erosion and sediment control methods has intended functions. Utilize the method that best controls erosion, sediment, turbidity, or pollution discharges from the project. Select protection methods from those detailed in the State of Florida Erosion and Sediment Control Designer and Reviewer Manual appropriate to the type of work.

104-4.6 Erosion and Sediment Control Device Inspection and Maintenance: Using a FDEP certified inspector, inspect all erosion and sediment control devices in accordance with the Construction Generic Permit. Immediately correct any deficiencies. In addition, make a daily review of the location of erosion and sediment control devices in areas where construction activities have changed the natural contour and drainage runoff to ensure that the erosion and sediment control devices are properly located for effectiveness. Where deficiencies exist, install additional erosion and sediment control devices to conform to permit requirements.

Maintain permanent and temporary erosion and sediment control features, at no expense to the Department, until the project is complete and accepted. If reconstruction of such erosion and sediment control features is necessary due to the Contractor's negligence or carelessness or, in the case of temporary erosion and sediment control features, failure by the Contractor to install permanent erosion or sediment control features as scheduled, the Contractor shall replace such erosion or sediment control features at no expense to the Department. If reconstruction of permanent or temporary erosion and sediment control features is necessary, as determined by the Engineer, due to factors beyond the control of the Contractor, the Department will consider payment for replacement pursuant to 4-4, Unforeseeable Work.

Maintain all erosion and sediment control features as required in the Stormwater Pollution Prevention Plan, Contractor's project specific erosion and sediment control plan and as specified in the State of Florida Department of Environmental Protection Generic Permit for Stormwater Discharge from Large and Small Construction Activities.

Dress any sediment deposits remaining in place after the temporary erosion and sediment control devices are no longer required to conform to the finished grade, and prepare them in accordance with Section 570.

104-4.7 Performance Standards for Sediment and Erosion Control Plan and Water Quality Monitoring Requirements: Completely retain eroded soils and turbid water on the project site and do not discharge into wetlands or surface waters on any portion of the job site for the duration of the project.

Prior to starting construction, conduct water quality sampling in the receiving waters at points above, within and below the project site to establish a baseline assessment of turbidity for the waterbody. Inspect the project site per the requirements of the NPDES CGP.

When a visible stormwater discharge is detected during a rain event, sample all stormwater discharge points that leave the project site for turbidity. Provide the turbidity monitoring results to the engineer with the weekly inspection reports required by the CGP. Discharged stormwater turbidity must be ≤ 29 Nephelometric Turbidity Units (NTU) above background for surface waters and must be 0 NTUs above background for any waterbody designated as an Outstanding Florida Water. Sediment migration off site and discharge of turbid water above state standards is a violation of the permit and corrective measures must be performed immediately.

104-4.8 Removal of Temporary Erosion Control Features: Remove temporary erosion and sediment control devices only after the protected areas are permanently stabilized or as directed by the Engineer. Final Acceptance in accordance with 5-11 will not be issued until all required temporary erosion and sediment control devices have been satisfactorily removed and disposed.

104-4.9 Protection During Suspension of Contract Time: If the Engineer determines it is necessary to suspend the construction operations for any appreciable length of time, inspect installed erosion and sediment control devices and install, as needed, additional measures to prevent erosion and sediment transport from the site. During such suspensions of operations, perform additional erosion and sediment control work as required by the Engineer. Payment for additional work during periods of Department directed suspensions will be in accordance with 4-4 as unforeseeable work.

In the event of a suspension of work due to a named storm event, remove existing temporary erosion or sediment control devices as directed by the Engineer. Payment for removal and subsequent replacement, if necessary, will be in accordance with 4-4 as unforeseeable work.

104-5 Method of Measurement.

The quantity paid will be the lump sum quantity for all work specified in this Section, completed and accepted.

104-6 Basis of Payment.

Price and payment will be full compensation for all work specified in this Section. Separate payment will not be made for the cost of constructing temporary earth berms along the edges of roadways to prevent

erosion or sediment transport during grading and subsequent operations. Include these costs in the unit prices for grading.

If the requirements of this Section are not satisfied, the Engineer may employ outside assistance or use Department employees to perform corrective measures as needed. The monthly progress estimate will be reduced by any such costs incurred, including engineering costs.

Payment will be made under: Item No. 908-104-1 - Erosion and Sediment Control - LS

APPENDIX A

AS-BUILTS REQUIREMENT CHECKLIST



Nassau County Engineering Services Department
96161 Nassau Place
Yulee, Florida 32097

AS-BUILT REQUIREMENT CHECKLIST:

The following list is intended to highlight the majority of the as-built requirements for Construction projects in Nassau County. This list should not be considered to be all-inclusive as each project is unique in nature and may require additional information that can only be determined during the course of the project's completion. Generally, however, the AS-BUILT information shall contain the following:

1. AS-BUILTS should be based on the design plans as approved through the DRC process. The submitted as-builts should be at the same scale and have the same orientation as the design files.
2. AS-BUILTS should have the same page numbering as the design plans, and the cover of the AS-BUILT plans should have all sheets from the design plans listed with sheets not "AS-BUILT" stricken through.
3. AS-BUILTS should display the original design information as displayed on the plan sheets with the design information stricken through and the as-built information displayed in bold adjacent to the design information.
4. AS-BUILTS shall be accompanied by an "Engineer's Certification" form from the Engineer of Record. (Exhibits 3 & 4)
5. Three {3} sets of fully signed and sealed AS-BUILTS should be submitted along with CD containing the PDF file(s) and CADD file(s) of the AS-BUILT information. CADD files should be in State Plane coordinates (NAD 83) with a vertical datum of NAVD88 or NGVD 1929 (with the datum shift noted). Furthermore, CADD files should only be submitted in ACAD version 2013 or later.
6. Northing and Easting of all drainage structures should be included.
7. The plans should be clearly legible, and all structure notes, distances, angles and elevations should be clearly readable.
8. If the plan represents a phase of a development, then that phase should be clearly identified for clarity and avoid confusion with future phases.
9. There should be a north arrow and scale on each sheet.
10. A legend should be included explaining the symbols used in the plans.
11. ALL sheets must be signed and sealed by a surveyor licensed in the State of Florida.



12. There should be sufficient "plan" and "as-built" elevations shown to verify that the streets were constructed substantially in accordance with the approved construction plans. Generally, the County will review all low points and high points in the street and verify that the minimum grade exists for each street. On straight sections between high and low points elevations should be taken every 200 feet.
13. All street curve radii should be shown on the plans or in a table.
14. Street widths and curb type should be identified for each street on each sheet.
15. Whenever there are islands within the streets the as-builts should include dimensions for these islands.
16. The paved radii of all Cui-de-Sacs should be listed and Cul-De-Sac center and edge of pavement or gutter elevations at quarter points shall be shown.
17. All underdrains should be shown with size, lengths, inverts and cleanouts all shown.
18. Where swales are utilized there should be sufficient flow line elevations and ditch cross sections to verify capacity of the channel.
19. There should be a comparison table of design and as-built pipe sizes, lengths, invert elevations, and pipe slopes.
20. The as-built surface area of the pond(s) at Normal Water Level (design) and Top of Bank (as-built) should be included.
21. The bottom elevation and area should be shown (2 locations min. per pond).
22. The surveyor shall certify by note (for each pond) that no slope is greater than 1:4 above the design NWL, unless the pond is fenced.
23. All structures in the pond (overflow weirs, etc.) should be included.
24. All water main and sewer main locations, size, lengths, inverts, etc.
25. All easements required (or on a plat) should be shown on the "As- BUILTS" and improvement located so as to verify improvements are within the easement. Easement not recorded as part of the recorded plat including drainage and right-of-way easements shall also be identified as "as-built". For these easements the book and page of their record, property to whom easement is dedicated and date of filing should be shown on as the "as-built". All improvements intended to be within these easements shall be shown as the "as-builts" to verify the improvements are within the easement. Wetlands are not reviewed by Nassau County and need not be shown.
26. Depict all storm drain and utility repair locations and methods.

APPENDIX B

PLANS AND DRAWINGS

NOTE: SOME DETAILS IN THESE DRAWINGS ARE TO BE CONSIDERED TYPICAL AND MAY NOT BE CALLED OUT ON PLANS. CONTRACTOR SHALL BECOME FAMILIAR WITH AND FOLLOW ALL DETAILS DURING CONSTRUCTION IN ALL TYPICAL AREAS.

REGISTERED DESIGN PROFESSIONAL
ASA R. GILLETTE, P.E.
FLORIDA P.E. NO. 56177

NASSAU ANIMAL CONTROL CATTERY ADDITION 86078 LICENSE ROAD FERNANDINA BEACH, FLORIDA

PREPARED BY:
GILLETTE AND ASSOCIATES, INC.
CERTIFICATE OF AUTHORIZATION NO.: 9332
20 SOUTH 4TH STREET
FERNANDINA BEACH, FL 32034
PHONE: 904-261-8819
ASA R. GILLETTE, P.E.
FL P.E. NO. 56177

DIFFERENTIAL PRESSURE (DP) FORCES FOR WIND LOAD
CATTERY ADDITION – NASSAU COUNTY ANIMAL CONTROL

| MAIN WIND FORCE RESISTING SYSTEM (MWFRS), V=125, EXP=B, RISK CAT. II, ENCLOSED | | | | | |
|--|------|--------|-----|------------|-------------------------|
| ITEM | AREA | HEIGHT | L/B | ROOF ANGLE | PRESSURE FORCE |
| MWFRS | ROOF | 10-FT | N/A | L.T. 40° | +22.2 / -45.3 PSF (MAX) |
| | WALL | 8-FT | 2.0 | N/A | +42.2 / +39.8 PSF |

| COMPONENT AND CLADDING WIND PRESSURES | | | | | |
|---|------|---------------------|---------|----------|----------|
| ULTIMATE WIND VELOCITY: $V_{ULT} = 125$ MPH EXP. CAT. "B" RISK CAT. II ENCLOSED | | | | | |
| NOMINAL WIND VELOCITY: $V_{NOM} = 101$ MPH EXP. CAT. "B" RISK CAT. II ENCLOSED | | | | | |
| LOCATION | ZONE | ROOF ANGLE | A eff. | P1 (PSF) | P2 (PSF) |
| ROOF | 1 | $\theta < 15^\circ$ | 10 S.F. | +17.5 | -27.7 |
| ROOF | 2 | $\theta < 15^\circ$ | 10 S.F. | +17.5 | -48.2 |
| ROOF | 3 | $\theta < 15^\circ$ | 10 S.F. | +17.5 | -71.3 |
| WALLS | 4 | N/A | 10 S.F. | +30.2 | -32.8 |
| WALLS | 5 | N/A | 10 S.F. | +27.7 | -50.0 |

- C&C WIND PRESSURE FORCES LISTED ABOVE ARE BASED ON NOMINAL WIND SPEEDS. REDUCTION ALLOWED PER PER SECTION 1609.3, FLORIDA BUILDING CODE 2017 (6TH EDITION). $P_{NOM} = (0.6)(P_{ULT})$
- MWFRS PRESSURE FORCES DERIVED FROM ASCE 7 CHAPTER 27 (27.5), PART 2, SIMPLIFIED METHOD (BUILDING CLASS 1)
- C&C PRESSURE FORCES DERIVED FROM CHAPTER 30 (30.7), PART 4, LOW RISE (SIMPLIFIED)
- ZONE 5 IS DEFINED AS 5-FT FROM EACH EXTERIOR WALL CORNER
- ZONE 4 IS DEFINED AS ALL OTHER EXTERIOR WALL AREA
- IMPACT RESISTANT GLAZING IS NOT REQUIRED PER ASCE 7 AND F.B.C. 2017

FLORIDA BUILDING CODE PARAMETERS:
OCCUPANCY CLASSIFICATION: GOVERNMENT/PUBLIC USE
BUILDING SHELL CONSTRUCTION: CMU AND WOOD
CONSTRUCTION TYPE: TYPE V, UNPROTECTED

SPACE PARAMETERS:
NEW ADDITION AREA: 940 SQ. FT.
USE: CATTERY
ROOF HEIGHT: 9'-10"±
ROOF PITCH: 1/4" / FT.

WIND LOAD BASIS:
FLORIDA BUILDING CODE, 2017 (6TH ED.) & ASCE 7
LOCATION: FERNANDINA BEACH, FL
WIND VELOCITY: 125 MPH
RISK CATEGORY: II
EXPOSURE CATEGORY: B
ADDITION MODELED AS ENCLOSED STRUCTURE
STRUCTURE DOES NOT LIE WITHIN A WIND BORNE DEBRIS REGION

- REFERENCES:
- 1) FLORIDA BUILDING CODE, 2017 (6TH ED.)
 - 2) ASCE 7
 - 3) AMERICAN CONCRETE INSTITUTION (ACI)
 - 4) AMERICAN INSTITUTE OF TIMBER CONSTRUCTION (AITC)
 - 5) NATIONAL ELECTRIC CODE (NEC), 2012

DRAWING LIST

- CVR – COVER SHEET
- SP-1.0 – SITE PLAN
- A-1.0 – ARCHITECTURAL GENERAL NOTES
- A-1.1 – FLOOR PLANS & ELEVATIONS
- A-1.2 – ROOF PLAN
- S-0.0 – STRUCTURAL GENERAL NOTES
- S-1.1 – FOUNDATION AND MASONRY WALL PLANS
- S-1.2 – ROOF FRAMING PLAN
- S-2.1 – SECTIONS
- M-1.0 – HVAC SPECIFICATIONS
- M-1.1 – MECHANICAL FLOOR PLAN
- M-2.1 – MECHANICAL SCHEDULE AND NOTES
- E-1.1 – ELECTRICAL FLOOR PLAN
- P-1.1 – PLUMBING AND GAS FLOOR PLAN

| REV | DATE | ITEM |
|-----|----------|-------------------------------------|
| A | 10/22/18 | OWNER REVIEW |
| B | 12/11/18 | ISSUE FOR PRICING |
| C | 04/23/19 | ADDED SPACE CONDITIONING |
| D | 06/06/19 | ADDED ERY TO MECHANICAL SYSTEM (R1) |
| E | 06/25/19 | REVISED PER OWNER COMMENTS (R2) |

GILLETTE & ASSOCIATES, INC.
CIVIL, ENVIRONMENTAL, MECHANICAL, & STRUCTURAL ENGINEERING
CERTIFICATE OF AUTHORIZATION NO. 9332
ASA R. GILLETTE, P.E. • FL P.E. NO. 56177
20 S. 4th STREET * FERNANDINA BEACH, FL 32034
PHONE: 904-261-8819 * www.gilletteassociates.com

**NASSAU ANIMAL CONTROL
CATTERY ADDITION**
86078 LICENSE ROAD
Fernandina Beach, Florida 32034

NOTE: SOME DETAILS IN THESE DRAWINGS ARE TO BE CONSIDERED TYPICAL AND MAY NOT BE CALLED OUT ON PLANS. CONTRACTOR SHALL BECOME FAMILIAR WITH AND FOLLOW ALL DETAILS DURING CONSTRUCTION IN ALL TYPICAL AREAS.

REGISTERED DESIGN PROFESSIONAL
ASA R. GILLETTE, P.E.
FLORIDA P.E. NO. 56177

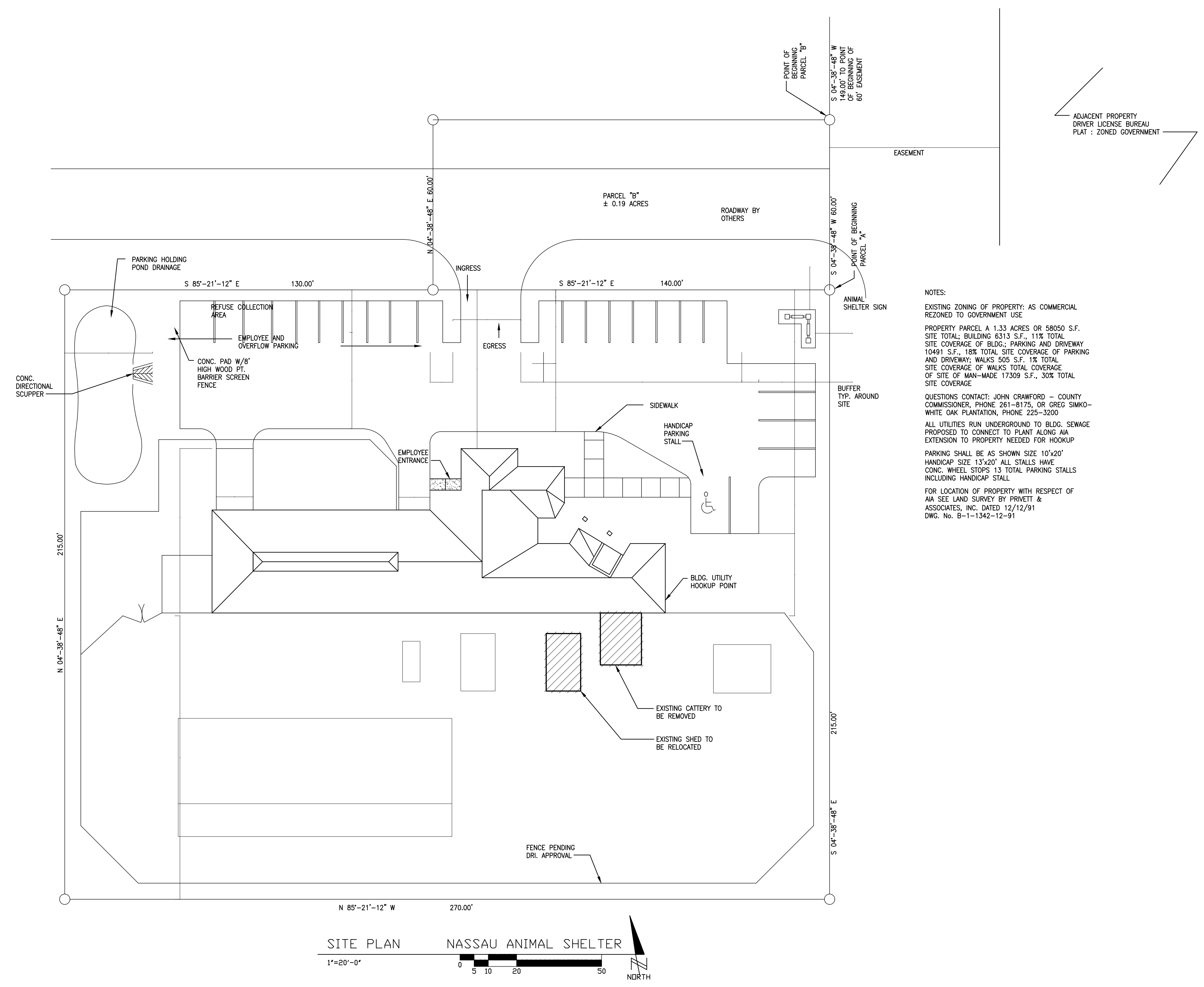

NOTES:
EXISTING ZONING OF PROPERTY: AS COMMERCIAL REZONED TO GOVERNMENT USE
PROPERTY PARCEL A 1.33 ACRES OR 58050 S.F. SITE TOTAL; BUILDING 6313 S.F., 11% TOTAL SITE COVERAGE OF BLDG.; PARKING AND DRIVEWAY 10491 S.F., 18% TOTAL SITE COVERAGE OF PARKING AND DRIVEWAY; WALKS 505 S.F., 1% TOTAL SITE COVERAGE OF WALKS TOTAL COVERAGE OF SITE OF MAN-MADE 17309 S.F., 30% TOTAL SITE COVERAGE
QUESTIONS CONTACT: JOHN CRAWFORD - COUNTY COMMISSIONER, PHONE 261-9175, OR GREG SIMKO - WHITE OAK PLANTATION, PHONE 235-3200
ALL UTILITIES RUN UNDERGROUND TO BLDG. SEWAGE PROPOSED TO CONNECT TO PLANT ALONG AIA EXTENSION TO PROPERTY NEEDED FOR HOOKUP
PARKING SHALL BE AS SHOWN SIZE 10'x20' HANDICAP SIZE 13'x20' ALL STALLS HAVE CONC. WHEEL STOPS 13 TOTAL PARKING STALLS INCLUDING HANDICAP STALL
FOR LOCATION OF PROPERTY WITH RESPECT OF AIA SEE LAND SURVEY BY PRIVETT & ASSOCIATES, INC. DATED 12/12/91 DWG. No. B-1-1342-12-91

| REV | DATE | ITEM |
|-----|----------|-------------------------------------|
| A | 10/22/18 | OWNER REVIEW |
| B | 12/11/18 | ISSUE FOR PRICING |
| C | 04/23/19 | ADDED SPACE CONDITIONING |
| D | 06/06/19 | ADDED ERY TO MECHANICAL SYSTEM (R1) |
| E | 06/25/19 | REVISED PER OWNER COMMENTS (R2) |

GILLETTE & ASSOCIATES, INC.
CIVIL, ENVIRONMENTAL, MECHANICAL, & STRUCTURAL ENGINEERING
CERTIFICATE OF AUTHORIZATION NO. 9332
ASA R. GILLETTE, P.E. • FL. P.E. NO. 56177
20 S. 4th STREET * FERNANDINA BEACH, FL 32034
PHONE: 904-261-8819 * www.gilletteassociates.com

**NASSAU ANIMAL CONTROL
CATTERY ADDITION**
86078 LICENSE ROAD
Fernandina Beach, Florida 32034

NOTE: SOME DETAILS IN THESE DRAWINGS ARE TO BE CONSIDERED TYPICAL AND MAY NOT BE CALLED OUT ON PLANS. CONTRACTOR SHALL BECOME FAMILIAR WITH AND FOLLOW ALL DETAILS DURING CONSTRUCTION IN ALL TYPICAL AREAS.

REGISTERED DESIGN PROFESSIONAL
ASA R. GILLETTE, P.E.
FLORIDA P.E. NO. 56177

ARCHITECTURAL GENERAL NOTES

GENERAL NOTES

- ALL DOOR HARDWARE TO BE ADA COMPLIANT.
- ALL INTERIOR SIGNAGE TO INSTALLED PER FBC 11-4.30 SIGNAGE. SIGNS SHALL BE INSTALLED ON WALLS ADJACENT TO LATCH SIDE OF DOOR. MOUNTING HT SHALL BE 60" AFF TO CENTERLINE OF SIGN. FACILITIES AND ELEMENTS REQUIRED TO BE IDENTIFIED AS ACCESSIBLE SHALL USE THE INTERNATIONAL SYMBOL OF ACCESSIBILITY.
- FIRE EXTINGUISHERS TO BE FURNISHED BY CONTRACTOR IN ACCORDANCE WITH LIFE SAFETY PLAN AND DRAWINGS (COORDINATE W/SUBCONTRACTORS).
- ALL ELECTRICAL WIRING TO BE IN CONDUIT. ALL CONDUIT TO BE CONCEALED.
- EXIT SIGNS - PER CODE REQUIREMENTS, DUAL VOLTAGE, BATTERY OPERATED, LITHONIA OR EQUAL.
- EMERGENCY BATTERY UNITS - AS REQUIRED BY CODE. LITHONIA UL-4 OR EQUAL. SEE ELECTRICAL DRAWINGS.
- SEE INTERIOR FINISH SCHEDULE FOR CEILING AND WALL TYPES.
- ALL EQUIPMENT TO BE PROVIDED AND INSTALLED BY OWNER. CONTRACTOR TO COORDINATE AS JOB PROGRESSES.
- CENTER ISLAND TO BE FURNISHED AND INSTALLED BY THE CONTRACTOR WITH COORDINATION BY THE OWNER TO MEET USE.

WATERPROOFING & PAINTING

- EXTERIOR JOINT SEALERS AND CAULKING TO BE APPLIED AT ALL JOINTS TO ACHIEVE MOISTURE AND AIR-TIGHT JOINTS. THE FOLLOWING ARE RECOMMENDED WITH EQUALS ACCEPTABLE:
URETHANES (TO BE COVERED)
- SIKAFLEX 15LM (LOW MODULUS)
- TREMCO VULKEM 921 (LOW MODULUS)
SILICONES (USE PRIMER AND SURFACE PREP AS REQ'D):
- DOW CORNING 795
- PECORA 795
- TREMCO SPECTUM II
- SIKA
- EXPOSED BLOCK (INTERIOR): PAINT SYSTEM TO BE THOROCOAT WATER-BASED, HIGH-BUILD, EPOXY WATERPROOF COATING (OR EQUAL) TO BE SUPPLIED WITH A 10-YEAR MANUFACTURER'S WARRANTY. SEAL PRIOR WITH THORO CM PRIMER (OR EQUAL). SEAL ALL CRACKS AND JOINTS IN ACCORDANCE WITH MANUFACTURER'S RECOMMENDATIONS PRIOR TO PAINTING.

EXPOSED BLOCK (EXTERIOR): ELASTOMERIC PAINT SYSTEM (OR EQUAL) WITH FINAL COLOR TO BE DETERMINED BY OWNER. (1) COAT PRIMER, (1) COAT SEALER. CLEAN AND PREP SURFACE PER MANUFACTURER'S SPECIFICATIONS.
- WOOD EXTERIOR: COAT OIL BASED/ALKYD PRIMER/SEALER, (2) COATS ACRYLIC. FINAL COLORS BY OWNER.
- RECOMMENDED JOINT CAULKING PARAMETERS (VERIFY WITH MANUFACTURER'S LITERATURE): JOINTS 1/4" TO 1/2" WIDE, WIDTH TO DEPTH TO BE EQUAL. JOINTS 1/2" WIDE OR GREATER SHOULD HAVE A SEALANT DEPTH OF 1/2". MINIMUM JOINT SIZE TO BE 1/4" X 1/4".

ROOFING SYSTEMS:

BASE BID:
MANUFACTURER: JOHNS MANSFIELD; DENVER, CO.
TYPE: SBS MODIFIED BITUMEN
INSULATION: JM ENERGY 3; 3" THK
COVER BOARD: DuraBoard; 1/2" THICK
MECH. FASTEN INSUL. AND COVER BOARD TO DECK
BASE SHEET: DynaPly
ADHESIVE: MBR COLD APPLICATION
CAP SHEET: DynaKap
FLASHING: PermaFlash SYSTEM

CEILING SYSTEM

1/2" TYPE 'X' GYPSUM BOARD. SAND SMOOTH, DUST AND CONDITION TO RECEIVE FINISH: (1) COAT LATEX PRIMER, (2) COATS FLAT OR SATIN ACRYLIC. SEE INTERIOR FINISH SCHEDULE FOR COLORS. MATERIAL SHALL BE CLASS B (F.S. INDEX 26-75-S-D 0-450).

WINDOWS AND DOORS

- STANDARDS/LABELING: EXTERIOR WINDOWS AND GLASS DOORS SHALL BE TESTED BY AN APPROVED INDEPENDENT TESTING LABORATORY, AND SHALL BE LABELED WITH AN APPROVED LABEL IDENTIFYING THE MANUFACTURER, PERFORMANCE CHARACTERISTICS AND APPROVED PRODUCT CERTIFICATION AGENCY AND FLORIDA BUILDING CODE COMPLIANCE.
- DESIGN PRESSURE PERFORMANCE TO BE IN ACCORDANCE WITH WIND LOAD PARAMETERS LISTED ON THE COVER SHEET.
- ALL EXTERIOR DOOR AND WINDOW ASSEMBLIES SHALL BE ANCHORED IN ACCORDANCE W/THE PUBLISHED MANUFACTURER'S RECOMMENDATIONS TO ACHIEVE MOUNTING STRENGTH FOR THE DESIGN PRESSURE SPECIFIED.
- ALL NEW WINDOWS TO BE DOUBLE PANE (INSULATED), 1/4" THICK GLASS. FRAMING TO BE ENERGY EFFICIENT VINYL OR SIMILAR.
- EXTERIOR DOORS TO BE INSULATED AND MANUFACTURED IN ACCORDANCE WITH CURRENT BUILDING CODE AND MEET CURRENT WIND LOADS LISTED ON THE COVER SHEET.
- INTERIOR DOORS DO NOT REQUIRE AN STC RATING.
- FINAL DOOR HARDWARE TO BE DETERMINED BY OWNER.
- ALL WINDOW AND DOOR SIZES SHOWN ON THE PLANS ARE APPROXIMATE. THE CONTRACTOR SHALL VERIFY ACTUAL DIMENSIONS AND USE STOCK SIZES WHENEVER POSSIBLE. ALLOW FOR ADDITIONAL BUCKING IN R.O. SIZES WHERE POSSIBLE IN MASONRY WALLS.
- INSULATE AROUND NEW DOORS AND WINDOWS W/ POLYFOAM OR SIMILAR.

FLOORING

CERAMIC TILE WITH 6" HIGH TILE BASE. PREP & INSTALL PER MANUFACTURER'S INSTRUCTIONS.

WALLS AND TRIM

- NEW EXTERIOR WINDOW AND DOOR TRIMS TO MATCH EXISTING BUILDING TRIM IN FINISH APPEARANCE.
- SUPPLY SAMPLES AS REQUIRED BY OWNER FOR APPROVAL PRIOR TO PROCUREMENT.

ALLOWANCES

- COSTS INCLUDED IN ALLOWANCES:
- DESIGN, MATERIALS & INSTALL: COST OF DESIGN TO CONTRACTOR; COST OF PRODUCT TO CONTRACTOR DELIVERED AT THE SITE, INSTALLATION, FINISHING, AND ALL REQUIRED TAXES, LESS APPLICABLE TRADE DISCOUNTS. COST TO INSTALL IS PART OF ALLOWANCE NUMBER.
- MATERIALS AND INSTALL: COST OF PRODUCT TO CONTRACTOR DELIVERED AT THE SITE, INSTALLATION, FINISHING, AND ALL REQUIRED TAXES, LESS APPLICABLE TRADE DISCOUNTS. COST TO INSTALL IS PART OF ALLOWANCE NUMBER.
- MATERIALS ONLY: COST OF PRODUCT TO CONTRACTOR DELIVERED AT THE SITE, ALL REQUIRED TAXES, LESS APPLICABLE TRADE DISCOUNTS; INSTALLATION COST SHALL BE INCLUDED IN THE BASE BID.
- COSTS NOT INCLUDED IN ALLOWANCES: CONTRACTOR'S COST FOR UNLOADING, STORING AND HANDLING AT THE SITE, OVERHEAD, PROFIT, AND OTHER EXPENSES CONTEMPLATED FOR STATED ALLOWANCE AMOUNTS SHALL BE INCLUDED IN THE CONTRACT BASE BID SUM AND NOT IN THE ALLOWANCES.
- FUNDS: DIFFERENCE IN COST WILL BE ADJUSTED BY CHANGE ORDER. CONTRACTOR TO COORDINATE ADJUSTMENT METHOD W/ OWNER PRIOR TO CONTRACT.
- CASH ALLOWANCE LIST: CONTRACTOR TO PROVIDE ITEMIZED PRICE BREAKDOWN AT THE TIME OF BID FOR OWNER'S EVALUATION. IN WRITING, LIST PRICES IN SAME ORDER AND BY CATEGORY FOR OWNER'S REVIEW.

| REV | DATE | ITEM |
|-----|----------|-------------------------------------|
| A | 10/22/18 | OWNER REVIEW |
| B | 12/11/18 | ISSUE FOR PRICING |
| C | 04/23/19 | ADDED SPACE CONDITIONING |
| D | 06/06/19 | ADDED ERY TO MECHANICAL SYSTEM (R1) |
| E | 06/25/19 | REVISED PER OWNER COMMENTS (R2) |

GILLETTE & ASSOCIATES, INC.
CIVIL, ENVIRONMENTAL, MECHANICAL, & STRUCTURAL ENGINEERING
CERTIFICATE OF AUTHORIZATION NO. 9332
ASA R. GILLETTE, P.E. * FL. PE. NO. 56177
20 S. 4th STREET * FERNANDINA BEACH, FL 32034
PHONE: 904-261-8819 * www.gilletteassociates.com

**NASSAU ANIMAL CONTROL
CATTERY ADDITION**
86078 LICENSE ROAD
Fernandina Beach, Florida 32034

NOTE: SOME DETAILS IN THESE DRAWINGS ARE TO BE CONSIDERED TYPICAL AND MAY NOT BE CALLED OUT ON PLANS. CONTRACTOR SHALL BECOME FAMILIAR WITH AND FOLLOW ALL DETAILS DURING CONSTRUCTION IN ALL TYPICAL AREAS.

REGISTERED DESIGN PROFESSIONAL
ASA R. GILLETTE, P.E.
FLORIDA P.E. NO. 56177

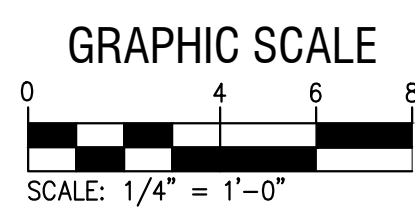
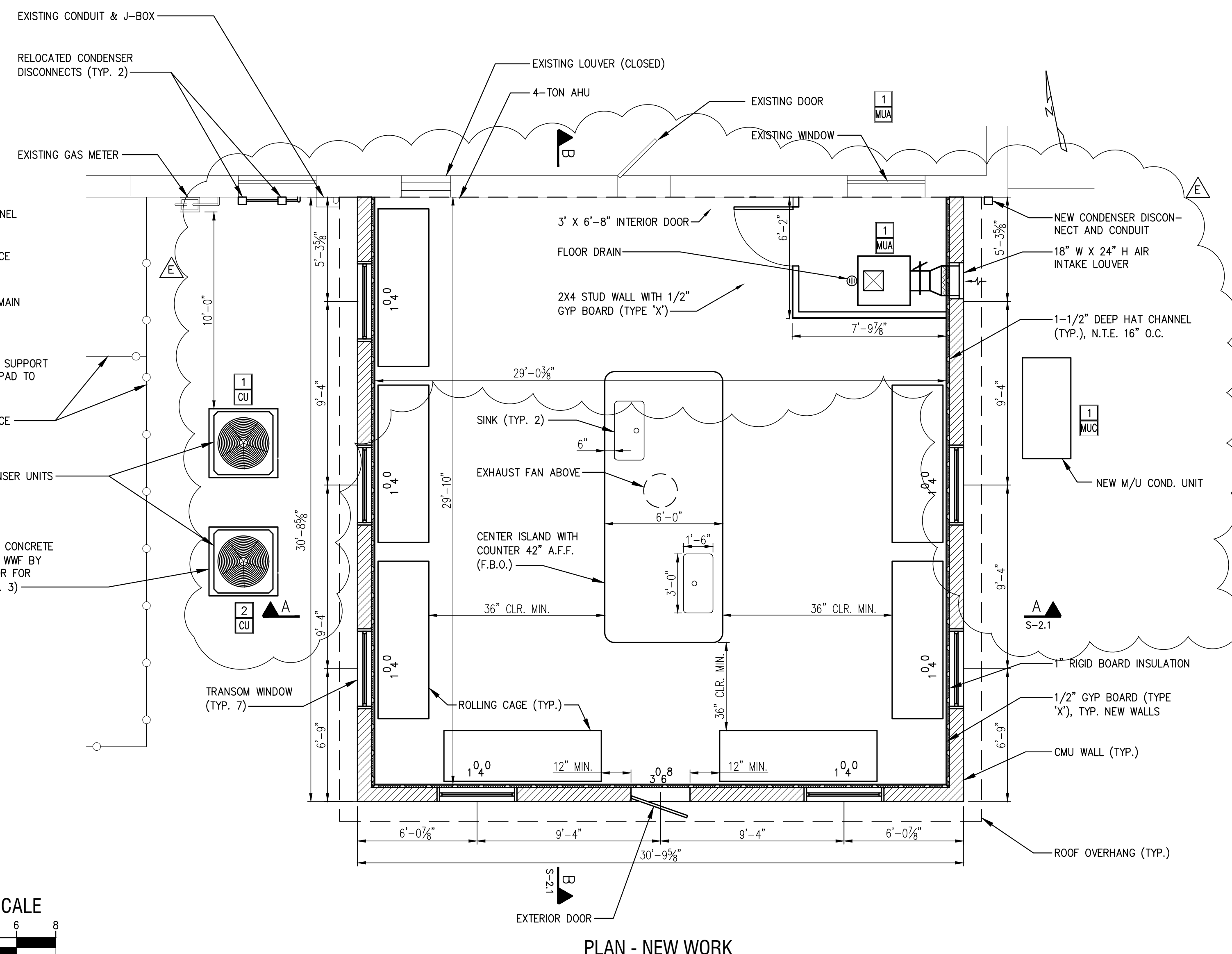
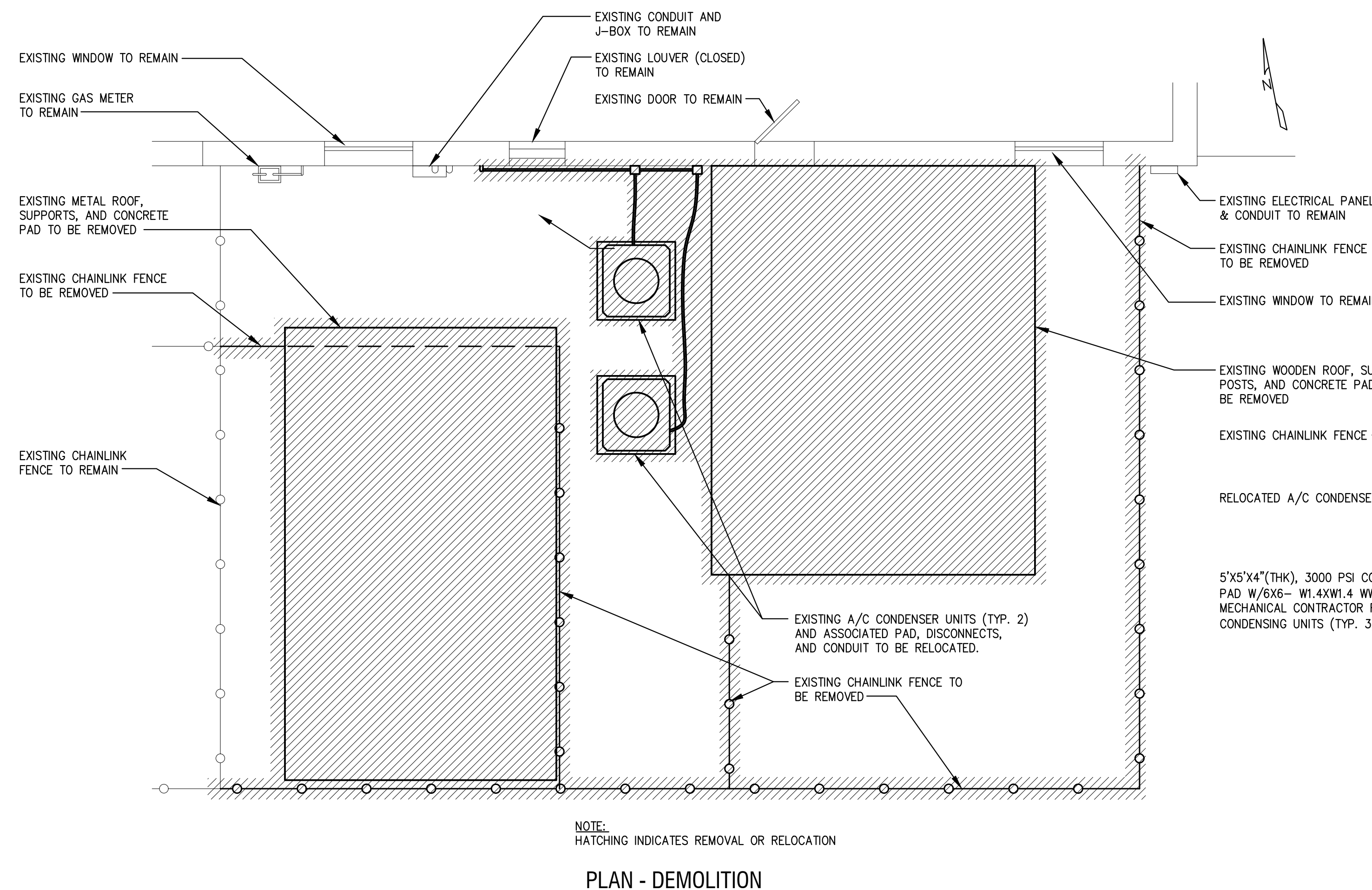
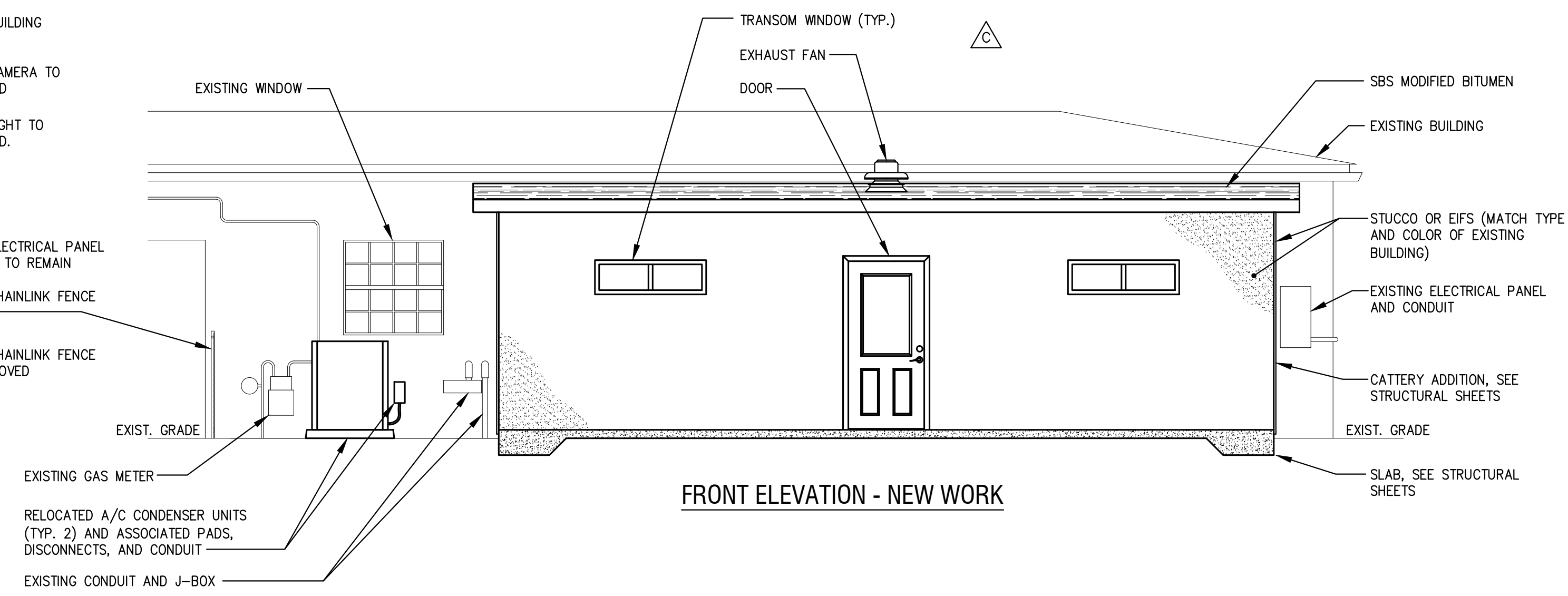
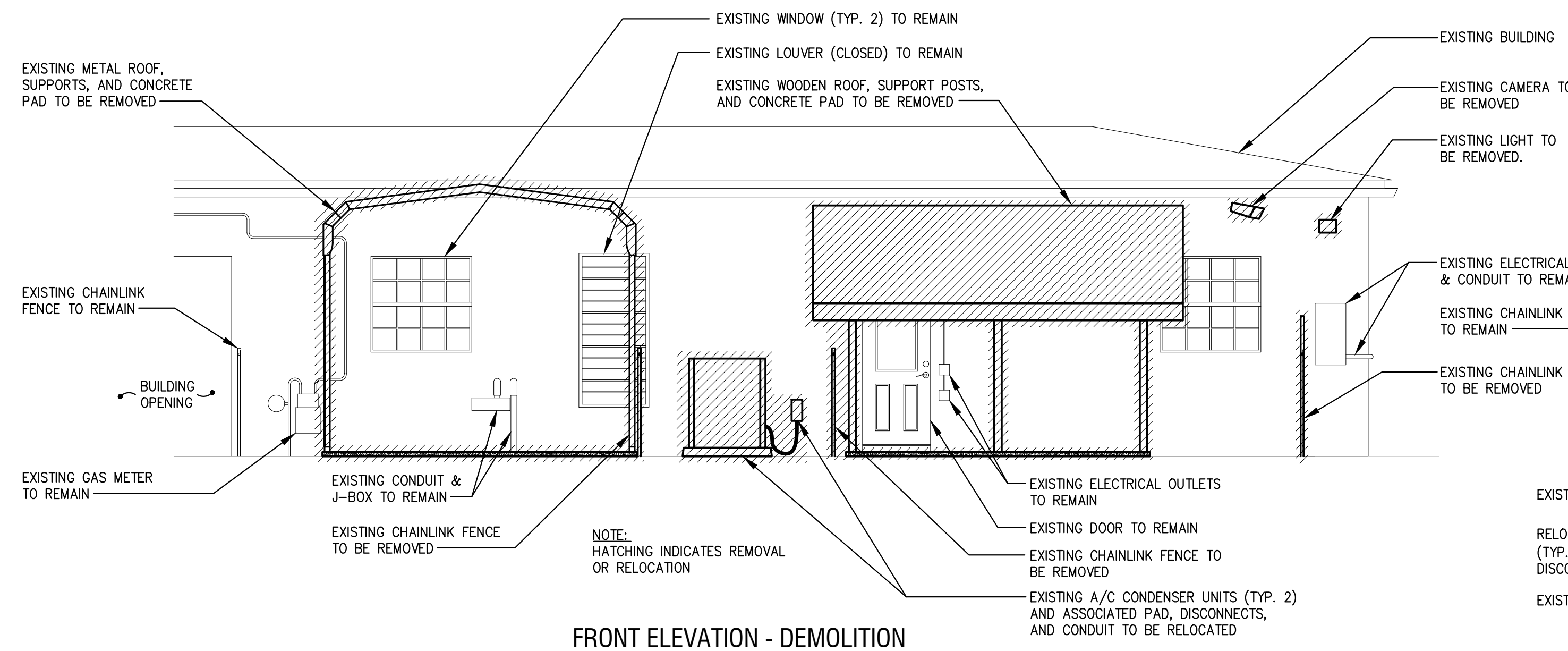

| REV | DATE | DESCRIPTION |
|-----|----------|--|
| A | 10/22/18 | OWNER REVIEW |
| B | 12/11/18 | ISSUE FOR PRICING |
| C | 04/23/19 | ADDED SPACE CONDITIONING |
| D | 06/06/19 | ADDED ERY TO MECHANICAL SYSTEM (R1) |
| E | 06/25/19 | DELETED ERY; REVISED PER OWNER COMMENTS (R2) |

GILLETTE & ASSOCIATES, INC.
CIVIL, ENVIRONMENTAL, MECHANICAL, & STRUCTURAL ENGINEERING
CERTIFICATE OF AUTHORIZATION NO. 9332
ASA R. GILLETTE, P.E. • FL. P.E. NO. 56177
20 S. 4th STREET * FERNANDINA BEACH, FL 32034
PHONE: 904-261-8819 * www.gilletteassociates.com

**NASSAU ANIMAL CONTROL
CATTERY ADDITION**
86078 LICENSE ROAD
Fernandina Beach, Florida 32034

NOTE: SOME DETAILS IN THESE DRAWINGS
MAY NOT BE CALLED OUT ON PLANS.
CONTRACTOR SHALL BECOME FAMILIAR
WITH AND FOLLOW ALL DETAILS DURING
CONSTRUCTION IN ALL TYPICAL AREAS.

REGISTERED DESIGN PROFESSIONAL
ASA R. GILLETTE, P.E.
FLORIDA P.E. NO. 56177

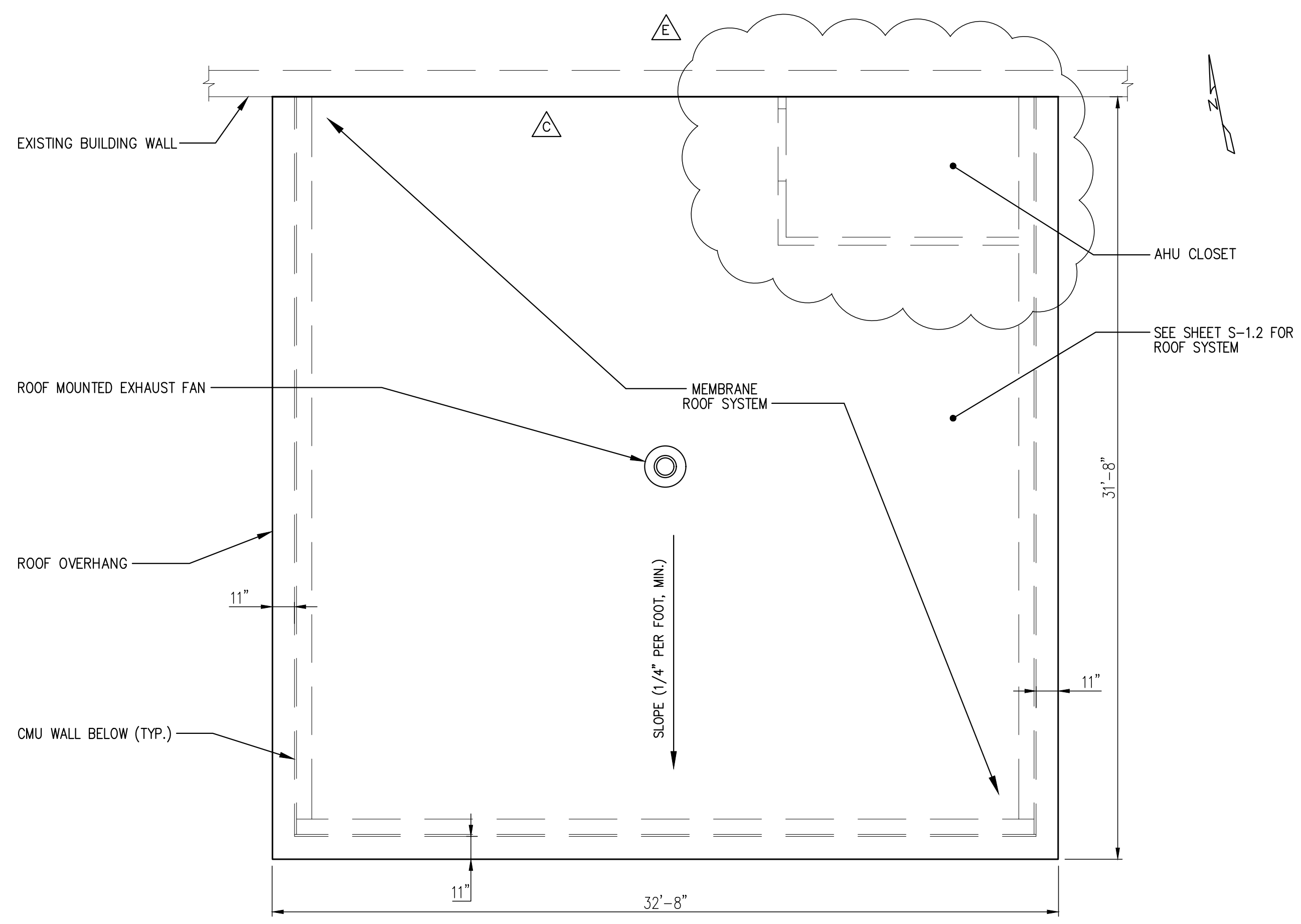

ROOF PLAN

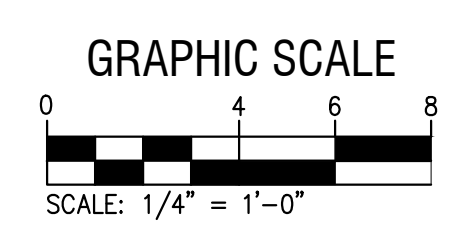

| REV | DATE | ITEM |
|-----|----------|--|
| A | 10/22/18 | OWNER REVIEW |
| B | 12/11/18 | ISSUE FOR PRICING |
| C | 04/23/19 | ADDED SPACE CONDITIONING |
| D | 06/06/19 | ADDED ERY TO MECHANICAL SYSTEM (R1) |
| E | 06/25/19 | DELETED ERY, REVISED PER OWNER COMMENTS (R2) |

GILLETTE & ASSOCIATES, INC.
CIVIL, ENVIRONMENTAL, MECHANICAL, & STRUCTURAL ENGINEERING
CERTIFICATE OF AUTHORIZATION NO. 9332
ASA R. GILLETTE, P.E. • FL. P.E. NO. 56177
20 S. 4th STREET * FERNANDINA BEACH, FL 32034
PHONE: 904-261-8819 * www.gilletteassociates.com

**NASSAU ANIMAL CONTROL
CATTERY ADDITION**
86078 LICENSE ROAD
Fernandina Beach, Florida 32034

NOTE: SOME DETAILS IN THESE DRAWINGS ARE TO BE CONSIDERED TYPICAL AND MAY NOT BE CALLED OUT ON PLANS. CONTRACTOR SHALL BECOME FAMILIAR WITH AND FOLLOW ALL DETAILS DURING CONSTRUCTION IN ALL TYPICAL AREAS.

REGISTERED DESIGN PROFESSIONAL
ASA R. GILLETTE, P.E.
FLORIDA P.E. NO. 56177

| REV | DATE | ITEM |
|-----|----------|-------------------------------------|
| A | 10/22/18 | OWNER REVIEW |
| B | 12/11/18 | ISSUE FOR PRICING |
| C | 04/23/19 | ADDED SPACE CONDITIONING |
| D | 06/06/19 | ADDED ERY TO MECHANICAL SYSTEM (R1) |
| E | 06/25/19 | REVISED PER OWNER COMMENTS (R2) |

GILLETTE & ASSOCIATES, INC.
CIVIL, ENVIRONMENTAL, MECHANICAL, & STRUCTURAL ENGINEERING
CERTIFICATE OF AUTHORIZATION NO. 9332
ASA R. GILLETTE, P.E. • FL. P.E. NO. 56177
20 S. 4th STREET * FERNANDINA BEACH, FL 32034
PHONE: 904-261-8819 * www.gilletteassociates.com

**NASSAU ANIMAL CONTROL
CATTERY ADDITION**
86078 LICENSE ROAD
Fernandina Beach, Florida 32034

STRUCTURAL GENERAL NOTES

I. GENERAL

- CONTRACTOR SHALL VERIFY ALL DIMENSIONS AND ELEVATIONS RELATED TO CONSTRUCTION BY MAKING FIELD MEASUREMENTS PRIOR TO COMMENCING WORK.
- TEMPORARY SHORING AND BRACING FOR CONSTRUCTION IS THE RESPONSIBILITY OF THE CONTRACTOR.
- ALL EXCAVATED MATERIAL AND CONSTRUCTION DEBRIS SHALL BE REMOVED FROM THE SITE AND DISPOSED OF BY THE CONTRACTOR.

II. CODE

- FLORIDA BUILDING CODE 2017 (6TH EDITION).
- ASCE 7
- AMERICAN CONCRETE INSTITUTE (ACI)
- AMERICAN INSTITUTE OF TIMBER CONSTRUCTION (AITC)
- NATIONAL ELECTRICAL CODE (NEC), 2012

III. DESIGN LOADS

- ROOF LIVE LOAD----- 25 PSF
- ROOF DEAD LOAD----- 20 PSF
- CEILING DEAD LOAD----- 5 PSF
- ROOF WIND LOAD----- SEE COVER SHEET
- FLOOR LIVE LOAD -----100 PSF
- FLOOR DEAD LOAD ----- 25 PSF

IV. DESIGN WIND LOADS

- ULTIMATE WIND SPEED ----- 125 MPH
- NOMINAL WIND SPEED ----- 101 MPH
- RISK CATEGORY ----- II
- ENCLOSURE CLASSIFICATION ----- ENCLOSED
- WIND EXPOSURE FACTOR ----- B

- PER ASCE 7, IMPACT RESISTANT GLAZING IS NOT REQUIRED

V. FOUNDATIONS

- PLACE GRANULAR FILL IN 8" LAYERS AND COMPACT TO A MINIMUM OF 95% OF THE MAXIMUM MODIFIED PROCTOR DRY DENSITY AS DETERMINED BY ASTM D-1557.
- DEWATER AS REQUIRED, SUCH THAT THE EXCAVATIONS ARE DRY AT THE TIME OF CONCRETE PLACEMENT.
- THE ENGINEER SHALL APPROVE THE FILL MATERIAL.
- REMOVE ALL TURF AND ORGANIC MATERIALS FROM UNDER THE PROPOSED FOUNDATION AND FLOOR AREA.
- SOIL BEARING STRENGTH PER GEOTECHNICAL REPORT BY AGES, INC.

VI. CONCRETE

- THE LATEST EDITIONS OF THE FOLLOWING STANDARDS SHALL APPLY:
ACI 318 (CODE) ACI 304 (PLACING)
ACI 306 (WINTER CONCRETING) ACI 315 (DETAILING)
ACI 305 (HOT WATER CONCRETING) ACI 347 (FORMWORK)
ACI 211.1 (MIX COMPRESSIVE)
- THE REQUIRED CONCRETE STRENGTH BASED ON AN AGE OF 28 DAYS FOR ELEMENTS IN THE STRUCTURE SHALL NOT BE LESS THAN:
3000 PSI FOR FOOTINGS AND SLABS.
- ALL READY-MIXED CONCRETE SHALL COMPLY WITH ASTM C94-86A.
- MIX PROPORTION AND DESIGN: PROPORTIONS, MIXES, COMPLYING MIX DESIGN PROCEDURES SPECIFIED IN ACI 301.
A. LIMIT OF FLY ASH (ASTM C808 TYPE C OR F) TO NOT TO EXCEED 25% OF PORTLAND CEMENT (ASTM C150 TYPE 1 OR 2) CONTENT BY WEIGHT. DO NOT USE FLY ASH IN CONJUNCTION WITH BLAST FURNACE SLAG.
B. DESIGN MIXES TO PROVIDE NORMAL WEIGHT CONCRETE WITH THE FOLLOWING PROPERTIES:
1. WATER-CEMENT RATIO ----- 0.55 MAXIMUM
2. AIR INTRAINMENT (ASTM C 260): 3% ± 1%
C. SLUMP LIMITS: PROPORTION AND DESIGN MIXES TO RESULT IN CONCRETE SLUMP AT A POINT OF PLACEMENT AS FOLLOWS:
1. RAMPS AND SLOPING SURFACES: NOT MORE THAN 3 INCHES.
2. OTHER CONCRETE: 4" ± 1".
D. FINE AND COARSE SHALL BE PER ASTM C33.
- SITE ADDED WATER IS PERMITTED WITHIN THE FIRST 15 MINUTES AFTER THE TRUCK ARRIVES ON THE JOB PROVIDED THAT THE WATER CEMENT RATIO AND THE SLUMP LIMITS ARE NOT EXCEEDED, HOWEVER NOT MORE THAN ONE GALLON OF WATER PER CUBIC YARD OF CONCRETE MAY BE USED TO ADJUST THE MIX AT THE JOB SITE.
- CONSOLIDATE ALL CONCRETE, OTHER THAN SLABS ON GRADE USING MECHANICAL VIBRATING EQUIPMENT.
- DO NOT PLACE CONCRETE DURING RAIN OR IF ANY RAIN IS LIKELY TO OCCUR PRIOR TO CONCRETE HARDENING.
- EPOXY ADHESIVE FOR FASTENING BOLTS, REBAR, OR DOWELS IN CONCRETE SHALL BE EITHER SIMPSON "AT" OR HILTI HY 150.
- ALL REINFORCING STEEL SHALL BE SUPPORTED ON STANDARD ACCESSORIES, HELD RIGIDLY AND ACCURATELY IN PLACE, AND PROTECTED AGAINST DISPLACEMENT BEFORE AND DURING PLACEMENT OF CONCRETE.
- REINFORCEMENT CHAIR LEGS THAT REST ON CONCRETE SURFACES THAT WILL BE EXPOSED IN THE FINISHED STRUCTURE SHALL BE FABRICATED OF STAINLESS STEEL OR SHALL BE PLASTIC COATED.
- THE READY-MIXED CONCRETE PRODUCER SHALL SUBMIT TRIPLICATE DELIVERY TICKETS, ONE FOR THE CONTRACTOR, ONE FOR THE OWNER AND ONE FOR THE ENGINEER WITH EACH LOAD OF CONCRETE DELIVERED TO THE SITE.

12. DELIVERY TICKETS SHALL PROVIDE THE FOLLOWING INFORMATION:

- DATE.
- NAME OF READY-MIX CONCRETE PLANT.
- CONTRACTOR.
- JOB LOCATION.
- TYPE OF CEMENT STANDARD EARLY STRENGTH AND BRAND OF CEMENT.
- CEMENT CONTENT IN BAGS PER CUBIC YARD OF CONCRETE.
- TRUCK NUMBER.
- TIME DISPATCHED AND TIME UNLOADED.
- AMOUNT OF CONCRETE IN LOAD IN CUBIC YARDS.
- ADMIXTURES IN CONCRETE, IF ANY.
- TYPE AND MAXIMUM SIZE OF AGGREGATE.
- MAXIMUM ALLOWABLE SLUMP.
- TEMPERATURE OF MIX.

13. DURING CONCRETE PLACEMENT COMPLY WITH ACI 304R-85 AND THE FOLLOWING SPECIFIC REQUIREMENTS:

- PROVIDE THREE TEST CYLINDERS FROM EACH TRUCK LOAD OF CONCRETE MIXTURE FOR 7,14, AND 28 DAY CURE/STRENGTH TESTS.
- SHORT TROUGHS OR PIPES USED AS AIDS IN PLACING CONCRETE SHALL BE ARRANGED AND USED IN SUCH A MANNER THAT THE INGREDIENTS OF THE CONCRETE ARE NOT SEPARATED.
- DROPPING THE CONCRETE A DISTANCE OF MORE THAN 4 FEET OR DEPOSITING A LARGER QUANTITY AT ANY POINT AND RUNNING OR WORKING IT ALONG THE FORMS WILL NOT BE PERMITTED.
- SPECIAL CARE SHALL BE EXERCISED TO PREVENT SPLASHING CONCRETE ON FORMS AND REINFORCEMENT, AND ANY HARDENED DEPOSIT SHALL BE REMOVED BEFORE COVERING WITH FRESH CONCRETE.
- CONCRETE SHALL BE PLACED IN LAYERS NOT OVER 18" DEEP AND EACH LAYER SHALL BE VIBRATED INTO PLACE IN SUCH A MANNER AS WILL NOT CAUSE THE INGREDIENTS TO SEPARATE. WHERE NECESSARY, VIBRATION SHALL BE SUPPLEMENTED BY HAND SPADING TO SECURE THESE RESULTS. VIBRATIONS SHALL BE KEPT CONSTANTLY IN MOTION AND SHALL NOT BE HELD IN ONE LOCATION LONG ENOUGH TO DRAW A POOL OF GROUT OR WATER FROM THE CONCRETE. MAINTAIN ADDITIONAL MANPOWER AND SPARE EQUIPMENT TO AVOID BREAKDOWN.
- MAINTAIN REINFORCING IN THE PROPER POSITION DURING CONCRETE PLACEMENT OPERATIONS.

14. PROTECT FRESHLY PLACED CONCRETE FROM PREMATURE DRYING AND EXCESSIVE COLD OR HEAT, AND MAINTAIN WITHOUT DRYING AT A RELATIVELY CONSISTENT TEMPERATURE FOR A PERIOD OF TIME NECESSARY FOR HYDRATION OF CEMENT AND PROPER HARDENING.

15. START INITIAL CURING AS SOON AS FREE WATER HAS DISAPPEARED FROM CONCRETE SURFACE AFTER PLACING AND FINISHING. WEATHER PERMITTING, KEEP CONTINUOUSLY MOIST FOR NOT LESS THAN 72 HOURS.

16. PROTECT FRESHLY PLACED CONCRETE FROM PREMATURE DRYING AND EXCESSIVE COLD OR HEAT, AND MAINTAIN WITHOUT DRYING AT A RELATIVELY CONSISTENT TEMPERATURE FOR A PERIOD OF TIME NECESSARY FOR HYDRATION OF CEMENT AND PROPER HARDENING.

17. THE CONCRETE SHALL RECEIVE TOPPING OF WATERPROOF MEMBRANE AND SHALL HAVE A TOLERANCE OF 1/4" PLUS OR MINUS IN A 10 FOOT RADIUS, NON-ACCUMULATIVE.

18. HARD STEEL TROWEL FINISH THE CONCRETE SURFACE. SLABS SHALL BE TROWELED IMMEDIATELY AFTER FLOATING WITH A POWER-DRIVEN TROWEL= CONSOLIDATE SURFACES BY AN INITIAL AND A FINAL HAND TROWELING OPERATION. FINAL TROWELING SHALL BE DONE WHEN A RINGING SOUND IS PRODUCED AS THE TROWEL IS PASSED OVER THE SURFACE. THE FINISHED SURFACE SHALL BE FREE OF TROWEL MARKS AND UNIFORM IN TEXTURE AND APPEARANCE. FINAL SURFACE FINISH TO BE APPROVED BY THE ARCHITECT.

19. WHERE FLOOR DRAINS ARE INSTALLED IN FLOOR SLABS, THE FLOOR SHALL BE HELD LEVEL AROUND WALLS AND THE FLOORS SHALL HAVE A UNIFORM PITCH TO DRAINS OF WITH PITCH (SLOPE) AS SHOWN ON DWGS.

20. NOTE OMITTED.

VII. CONCRETE FORMWORK AND REINFORCING

- CHAMFER ALL EXPOSED CONCRETE OUTSIDE CORNERS. FORM CHAMFERS WITH 3/4" X 3/4" STRIPS, ACCURATELY FORMED AND SURFACED TO PRODUCE UNIFORMLY STRAIGHT LINES AND TIGHT EDGE JOINTS. EXTEND TERMINAL EDGES TO REQUIRED LIMIT AND MITER CHAMFER STRIPS AT CHANGES IN DIRECTION. EXPOSED INSIDE CORNERS MAY BE FORMED EITHER SQUARE OR CHAMFERED.
- THE DESIGN AND ENGINEERING OF THE FORMWORK AS WELL AS ITS CONSTRUCTION SHALL BE THE RESPONSIBILITY OF THE CONTRACTOR AND SHALL CONFORM TO "RECOMMENDED PRACTICE FOR CONCRETE FORMWORK", ACI 347-84.
- FORMS SHALL CONFORM TO SHAPE, LINES, AND DIMENSIONS SHOWN ON THE DRAWINGS. THEY SHALL BE SUBSTANTIAL AND DESIGNED TO SAFELY RESIST THE PRESSURE AND WEIGHT OF THE CONCRETE, AND SHALL BE PROPERLY TIED AND BRACED OR SHORED SO AS TO MAINTAIN POSITION AND SHAPE.
- DESIGN FORMWORK TO BE READILY REMOVABLE WITHOUT IMPACT, SHOCK, OR DAMAGE TO CAST-IN-PLACE CONCRETE SURFACES AND ADJACENT MATERIALS.
- PROPERLY BRACE AND TIE THE FORMS TOGETHER SO AS TO MAINTAIN POSITION AND SHAPE AND TO ENSURE SAFETY TO PERSONNEL DURING CONCRETE PLACEMENT.
- CONSTRUCT ALL BRACING, SUPPORTING MEMBERS, AND CENTERING OF AMPLE SIZE AND STRENGTH TO SAFELY CARRY, WITHOUT EXCESSIVE DEFLECTION, ALL DEAD AND LIVE LOADS TO WHICH THEY MAY BE SUBJECTED.
- PROPERLY SPACE THE FORMS APART AND SECURELY TIE THEM TOGETHER, USING METAL SPREADER TIES THAT GIVE POSITIVE TYING AND ACCURATE SPREADING.

8. REINFORCING BARS SHALL COMPLY WITH ASTM A615-86, GRADE 60, INCLUDING SUPPLEMENTARY REQUIREMENT S1.

9. FABRICATE REINFORCING BARS TO CONFORM TO REQUIRED SHAPES AND DIMENSIONS, COMPLYING WITH CRSI "DETAILING MANUAL-1980". IN CASE OF FABRICATING ERRORS, DO NOT REBEND OR STRAIGHTEN REINFORCEMENT IN A MANNER THAT WILL INJURE OR WEAKEN THE MATERIAL. FABRICATING TOLERANCES SHALL COMPLY WITH ACI 117-81.

10. ALL REINFORCING BARS SHALL BE PLACED IN ACCORDANCE WITH CRSI "RECOMMENDED PRACTICE FOR PLACING REINFORCING BARS", AND AS SPECIFIED ON DRAWINGS.

11. BARS SHALL BE PLACED TO THE TOLERANCE SPECIFIED IN ACI 117-81.

12. PLACE ALL REINFORCEMENT ACCORDING TO THE APPROVED PLACEMENT DRAWINGS. USE SUFFICIENT BAR SUPPORTS, TIE, ANCHORS, SIDE FORM SPACERS, ADDITIONAL REINFORCING BARS IF REQUIRED, AND OTHER ACCESSORIES TO HOLD ALL BARS SECURELY IN PLACE.

13. PLACE REINFORCEMENT TO OBTAIN NOT LESS THAN THE MINIMUM COVERAGES FOR CONCRETE PROTECTION. ARRANGE, SPACE, AND SECURELY TIE BARS AND BAR SUPPORTS TOGETHER WITH 16 GAUGE WIRE TO HOLD REINFORCEMENT ACCURATELY IN POSITION DURING CONCRETE PLACEMENT OPERATION. SET WIRE TIES SO THAT TWISTED ENDS ARE DIRECTED AWAY FROM EXPOSED CONCRETE SURFACES.

14. PROVIDE STANDARD REINFORCEMENT SPLICES BY LAPPING ENDS, PLACING BARS IN CONTACT, AND TYING WIRE TIGHTLY. COMPLY WITH REQUIREMENTS IN ACI 318-86 FOR MINIMUM LAP OF SPLICED BARS AND AS INDICATED ON DRAWINGS. REINFORCING BAR ASSEMBLIES SHALL NOT BE MADE BY TACK WELDING.

15. STEEL REINFORCEMENT, AT THE TIME CONCRETE IS PLACED AROUND IT, SHALL BE FREE FROM LOOSE RUST AND MILL SCALE, OIL, GREASE, PAINT, EARTH, ICE, AND ALL OTHER COATINGS, WHICH WOULD REDUCE OR DESTROY BOND BETWEEN STEEL AND CONCRETE. CLEAN REINFORCEMENT AS NECESSARY PRIOR TO PLACEMENT TO ACHIEVE THIS RESULT.

16. COORDINATE PLACEMENT OF REINFORCING WITH DUCTWORK AND OR PLUMBING LOCATIONS. SEE PLUMBING AND MECHANICAL DRAWINGS.

17. COORDINATE OPENINGS IN SLAB ABOVE GRADE FOR DUCTWORK AND PENETRATIONS.

VIII. WOOD FRAMING NOTES

- BLOCKING AT STUD WALLS --- PROVIDE ONE ROW OF 2X HORIZONTAL BLOCKING (SAME DEPTH AS STUD WALL) AT MID-HEIGHT OF ALL EXTERIOR AND INTERIOR BEARING WALLS 10'-0" OR LESS IN HEIGHT. FOR ALL WALLS GREATER THAN 10'-0", USE 2 ROWS OF BLOCKING. IN ADDITION, PROVIDE BLOCKING AT PLYWOOD JOINTS.
- GENERAL BLOCKING --- PROVIDE ALL BLOCKING FOR DRYWALL APPLICATION, WALL ANCHORING OF CABINETS, TRIM, BASEBOARDS, SOFFITS, TRAY CEILINGS, WOOD PANELING, ETC., TO ACHIEVE QUALITY FINISH JOB AND TO PREVENT WAVING OF DRYWALL AT TRIM.
- WOOD FURRING --- 1X4, LEVELED TO TOLERANCE OF 1/8" IN 10'X10'X0. (U.O.N.) ALL FURRING ON CONCRETE OR MASONRY TO BE PRESSURE TREATED.
- ROOF SHEATHING --- 3/4" THICK, TONGUE AND GROOVE SHEETS, COVERED WITH 2" THICK RIGID BOARD INSULATION (R-19). DEFAULT NAIL PATTERN TO BE 10d RING SHANK NAILS N.T.E. 4" O.C. EDGE, 6" O.C. FIELD. STAPLES NOT ALLOWED. NAILHEADS SHALL NOT PENETRATE SURFACE OF PLYWOOD MORE THAN THICKNESS OF NAIL HEAD.
- EXTERIOR WALL/INTERIOR SHEAR WALL SHEATHING ---NAIL EDGES AT 3" O.C. AND AT 6" O.C. AT INTERMEDIATE STUDS. USE 10d COMMON NAILS. ALL NAILS SHALL BE STAINLESS STEEL; DO NOT USE STAPLES. NAILHEADS SHALL NOT PENETRATE SURFACE OF SHEATHING MORE THAN THICKNESS OF NAIL HEAD.
- PLYWOOD SUBFLOOR --- GLUE AND NAIL TO JOISTS BELOW. SEAL PLYWOOD TO PROTECT AGAINST DAMAGE FROM RAIN DURING FRAMING STAGE.
- RAFTERS --- SEE ROOF FRAMING PLAN FOR ANCHORING OF RAFTERS TO WALLS OR BEAMS. ANCHOR ALL RAFTERS TO RIDGES, HIPS, AND VALLEYS WITH SIMPSON A35 FURNACE ANCHORS (U.O.N.)
- RIDGES --- WHERE TWO RAFTERS MEET A RIDGE BEAM, AND NO COLLAR TIES ARE USED, INSTALL (2) ST22 STRAP TIE OVER TOP OF BOTH RAFTERS.
- BUILT-UP BEAMS/HEADERS --- BUILT-UP MEMBERS SHALL BE MADE OF MIN. 2X LUMBER FASTENED TOGETHER WITH TWO ROWS OF 20d NAILS SPACED NOT LESS THAN 32" O.C. LOCATE ONE ROW NEAR TOP EDGE AND ONE ROW NEAR THE BOTTOM EDGE WHERE APPLICABLE.
- FLOOR JOISTS/TRUSSES --- ANCHOR ALL FLOOR JOISTS OR TRUSSES TO WALLS BELOW WITH MINIMUM (1) SIMPSON HUS212 FACE MOUNT ANCHOR AS SPECIFIED ON THE DRAWINGS.
G.C. TO COORDINATE INSTALLATION OF ALL PLUMBING W/ FJ/TRUSS LAYOUT PRIOR TO FINAL INSTALLATION. PROVIDE ADDITIONAL FJ/TRUSSES AS REQ'D IF PLUMBING HITS ON FRAMING AT TYPICAL SPACING.
- MINIMUM HEADER SIZES --- U.N.O., ALL EXTERIOR WALL HEADERS SHALL BE MIN. (3) 2x12'S, ALL INTERIOR LOAD-BEARING WALL HEADERS SHALL BE MIN. (3) 2X12'S, ALL INT. NON-LOAD BEARING WALL HEADERS SHALL BE MIN. (3) 2X10'S. SEE FRAMING PLANS FOR HEADER SIZES.

IX. MASONRY

- ALL LOAD BEARING WALLS AND EXTERIOR WALLS SHALL BE COMPOSED OF ASTM C90, GRADE N-1 HOLLOW CONCRETE MASONRY UNITS WITH ASTM C270, TYPE "S" MORTAR.
- ALL EXTERIOR CMU WALLS SHALL BE REINFORCED FULL HEIGHT IN A GROUT FILLED CELL AS NOTED ON MASONRY COLUMN PLANS
A. EACH CORNER, WALL ENDS, WALL INTERSECTIONS, EACH SIDE OF CONTROL JOINTS
B. AT BEAM BEARING LOCATIONS ADD 1 #5 IN CONCRETE FILLED CELL
- LAP VERTICAL BARS 4B DIAMETERS WITH WIRE TIES.
- GROUT ALL CELLS CONTAINING VERTICAL REINFORCEMENT IN 5'-0" MAXIMUM LIFTS. DO NOT BEGIN PLACEMENT OF GROUT UNTIL ALIGNMENT OF CELLS ARE INSPECTED AND APPROVED.
- PROVIDE HORIZONTAL JOINT REINFORCEMENT IN WALLS AT 16" O.C. VERTICALLY, U.N. IN ADDITION, INSTALL JOINT REINFORCING IN THE FIRST TWO MORTAR JOINTS ABOVE AND BELOW OPENINGS, EXTENDING AT LEAST 24 INCHES BEYOND THE OPENING. PROVIDE HORIZONTAL JOINT REINFORCEMENT IN PARAPETS AND FREE STANDING WALLS AT 8" O.C. VERTICALLY. LAP JOINT REINFORCEMENT 6" MINIMUM.
- MASONRY WORK SHALL BE INSPECTED IN ACCORDANCE WITH ACI 530.1.

NOTE: SOME DETAILS IN THESE DRAWINGS ARE TO BE CONSIDERED TYPICAL AND MAY NOT BE CALLED OUT ON PLANS. CONTRACTOR SHALL BECOME FAMILIAR WITH AND FOLLOW ALL DETAILS DURING CONSTRUCTION IN ALL TYPICAL AREAS.

REGISTERED DESIGN PROFESSIONAL
ASA R. GILLETTE, P.E.
FLORIDA P.E. NO. 56177

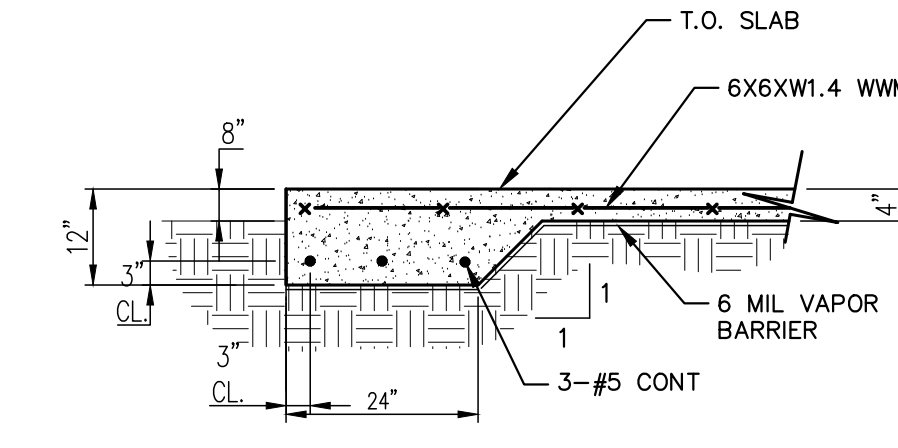

SECTION C-C
NOT TO SCALE

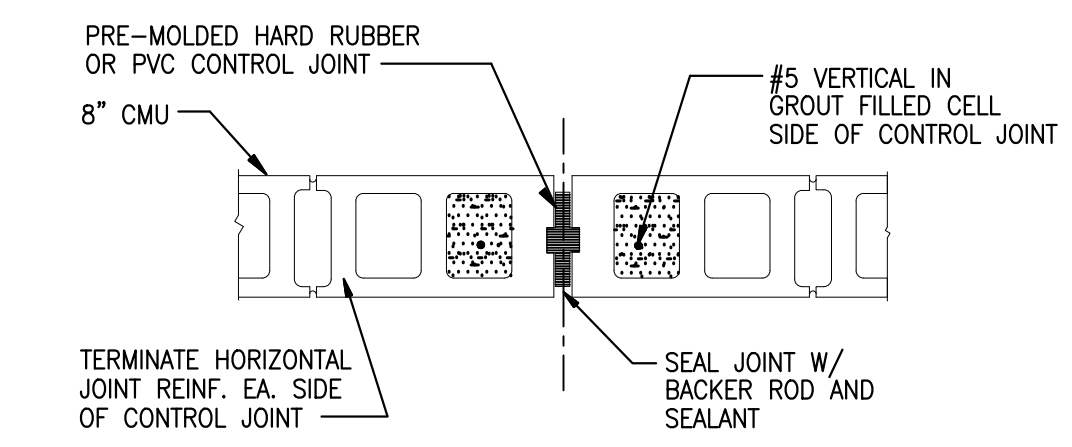

NOTE:
LOCATE MASONRY CONTROL JOINT AS PER PLAN
DETAIL #1 - MASONRY CONTROL JOINT
NOT TO SCALE

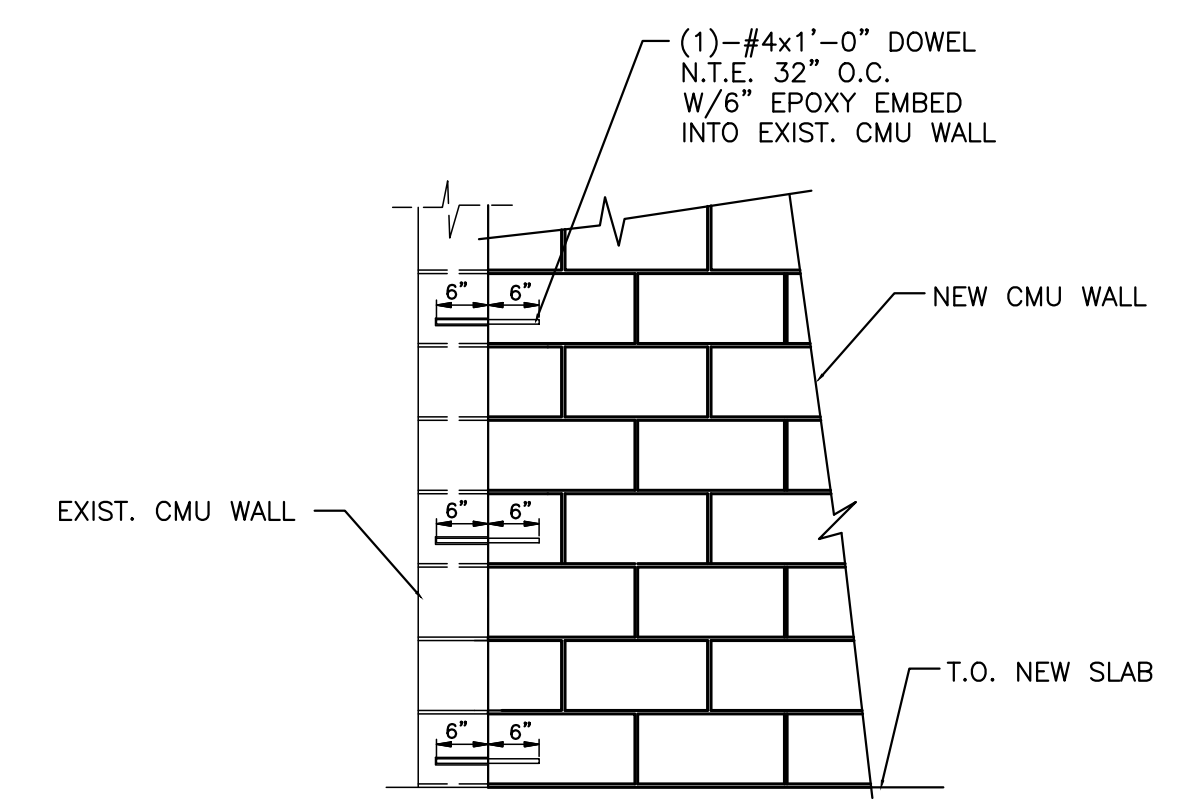

DETAIL #2 - NEW TO EXISTING MASONRY WALL
NOT TO SCALE

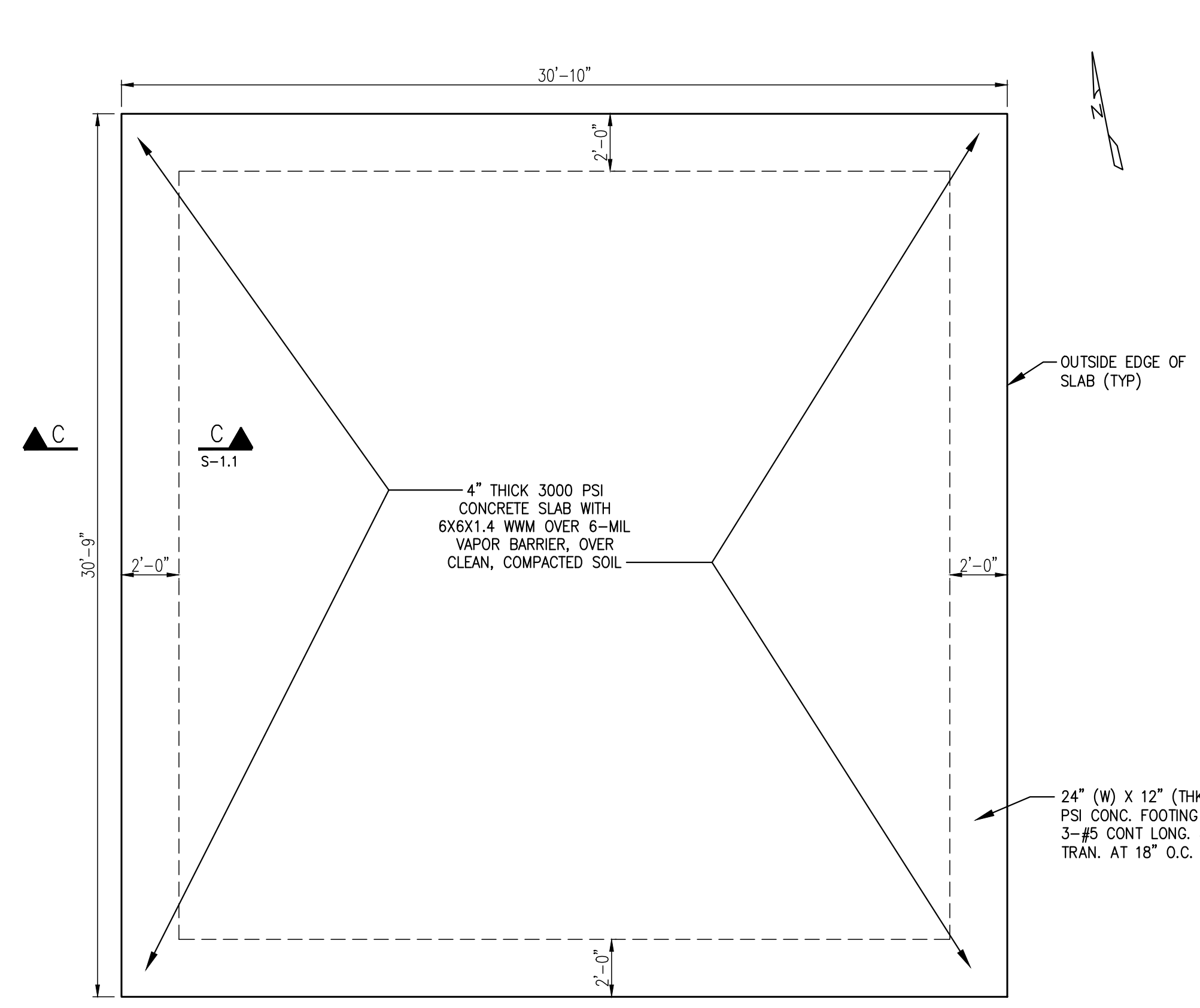

FOUNDATION PLAN

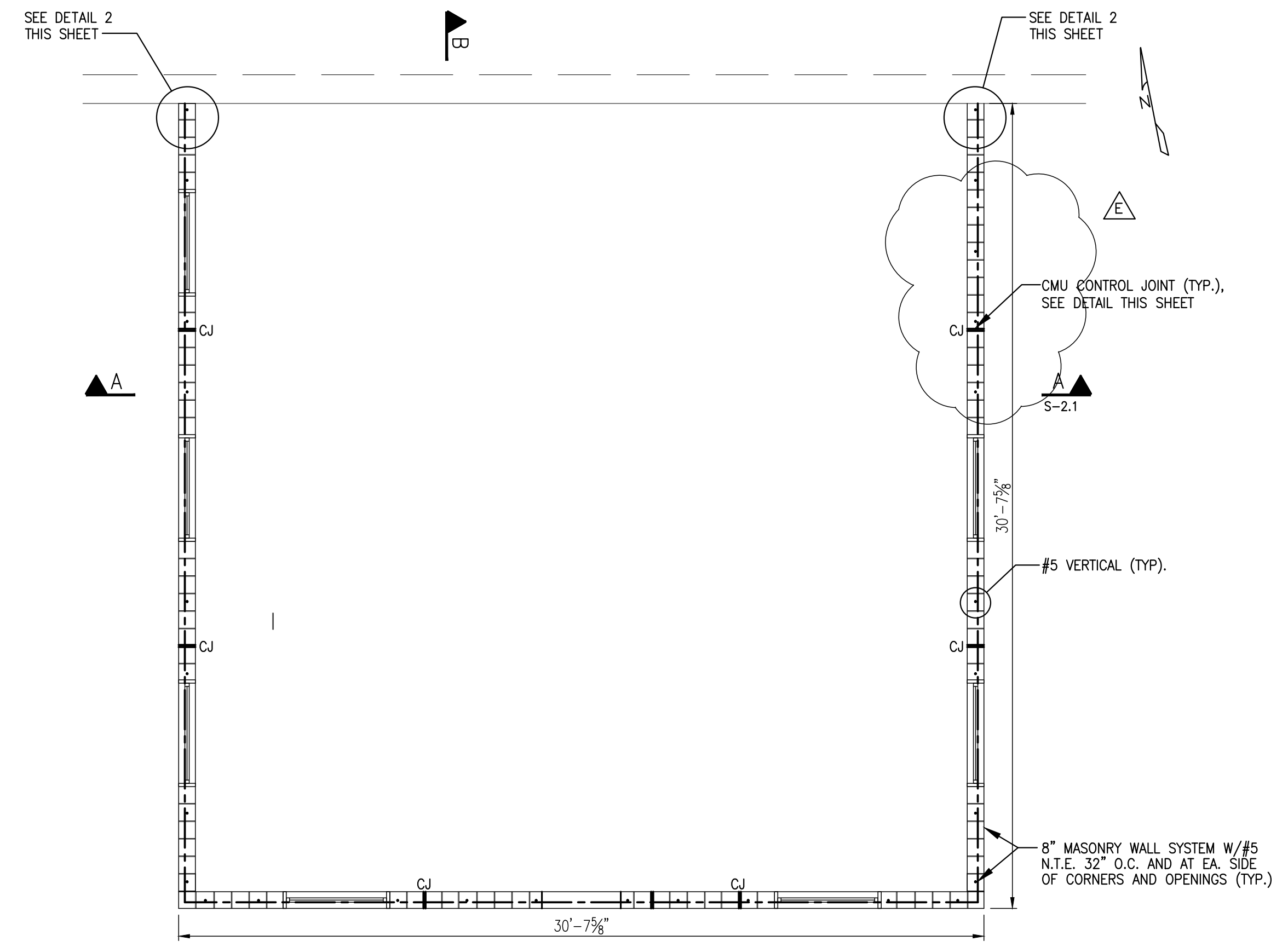

MASONRY WALL PLAN

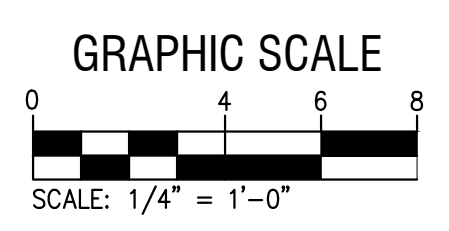

| REV | DATE | ITEM |
|-----|----------|-------------------------------------|
| A | 10/22/18 | OWNER REVIEW |
| B | 12/11/18 | ISSUE FOR PRICING |
| C | 04/23/19 | ADDED SPACE CONDITIONING |
| D | 06/06/19 | ADDED ERY TO MECHANICAL SYSTEM (R1) |
| E | 06/25/19 | REVISED PER OWNER COMMENTS (R2) |

GILLETTE & ASSOCIATES, INC.
CIVIL, ENVIRONMENTAL, MECHANICAL, & STRUCTURAL ENGINEERING
CERTIFICATE OF AUTHORIZATION NO. 9332
ASA R. GILLETTE, P.E. • FL. P.E. NO. 56177
20 S. 4th STREET * FERNANDINA BEACH, FL 32034
PHONE: 904-261-8819 * www.gilletteassociates.com

**NASSAU ANIMAL CONTROL
CATTERY ADDITION**
86078 LICENSE ROAD
Fernandina Beach, Florida 32034

NOTE: SOME DETAILS IN THESE DRAWINGS
MAY NOT BE CALLED OUT ON PLANS.
CONTRACTOR SHALL BECOME FAMILIAR
WITH AND FOLLOW ALL DETAILS DURING
CONSTRUCTION IN ALL TYPICAL AREAS.

REGISTERED DESIGN PROFESSIONAL
ASA R. GILLETTE, P.E.
FLORIDA P.E. NO. 56177

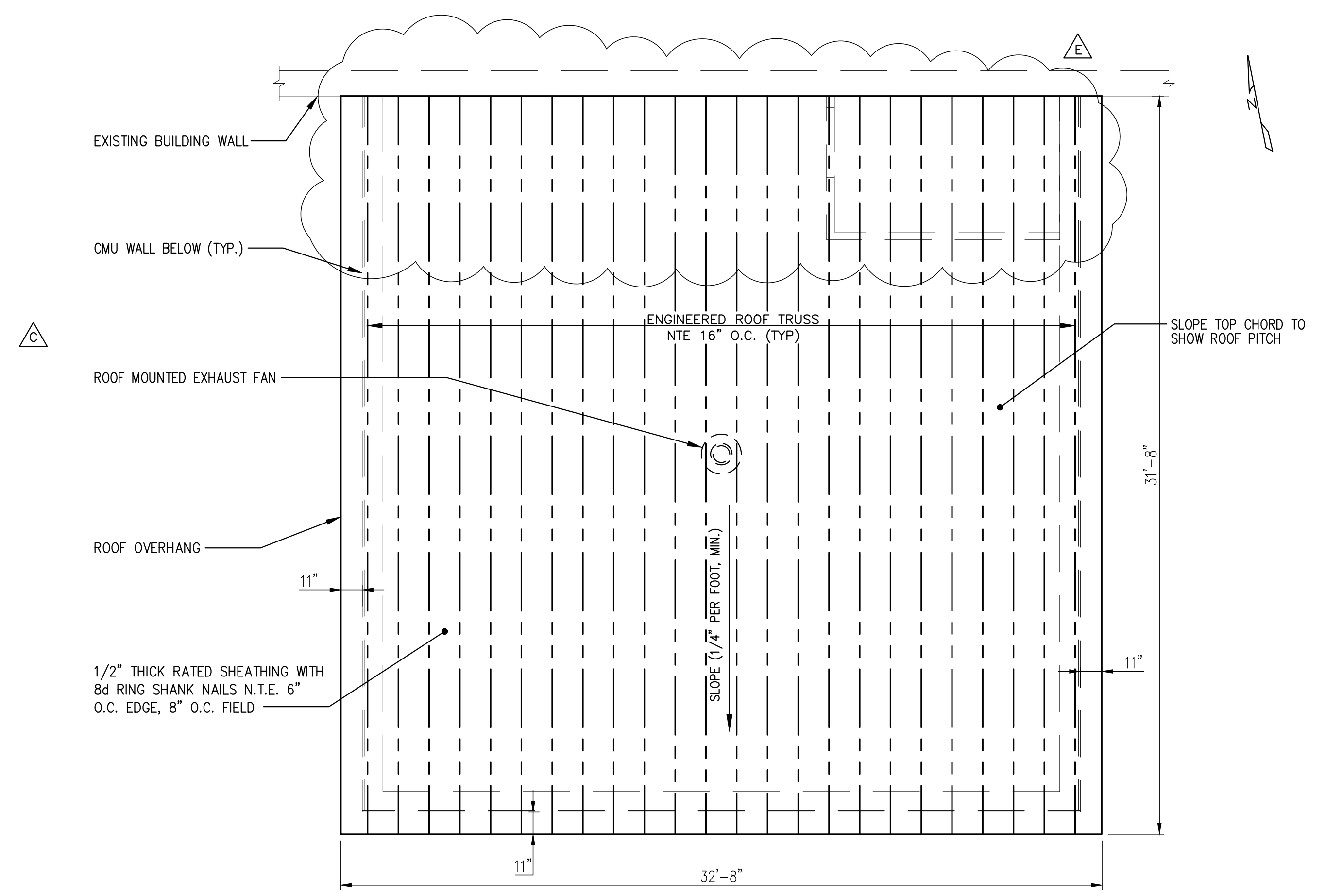

ROOF FRAMING PLAN

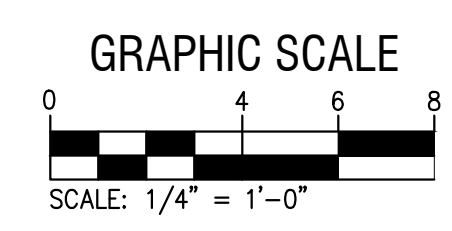

| REV | DATE | ITEM |
|-----|----------|--|
| A | 10/22/18 | OWNER REVIEW |
| B | 12/11/18 | ISSUE FOR PRICING |
| C | 04/23/19 | ADDED SPACE CONDITIONING |
| D | 06/06/19 | ADDED ERY TO MECHANICAL SYSTEM (R1) |
| E | 06/25/19 | DELETED ERY, REVISED PER OWNER COMMENTS (R2) |

GILLETTE & ASSOCIATES, INC.
CIVIL, ENVIRONMENTAL, MECHANICAL, & STRUCTURAL ENGINEERING
CERTIFICATE OF AUTHORIZATION NO. 9332
ASA R. GILLETTE, P.E. • FL. P.E. NO. 56177
20 S. 4th STREET * FERNANDINA BEACH, FL 32034
PHONE: 904-261-8819 * www.gilletteassociates.com

**NASSAU ANIMAL CONTROL
CATTERY ADDITION**
86078 LICENSE ROAD
Fernandina Beach, Florida 32034

NOTE: SOME DETAILS IN THESE DRAWINGS ARE TO BE CONSIDERED TYPICAL AND MAY NOT BE CALLED OUT ON PLANS. CONTRACTOR SHALL BECOME FAMILIAR WITH AND FOLLOW ALL DETAILS DURING CONSTRUCTION IN ALL TYPICAL AREAS.

REGISTERED DESIGN PROFESSIONAL
ASA R. GILLETTE, P.E.
FLORIDA P.E. NO. 56177

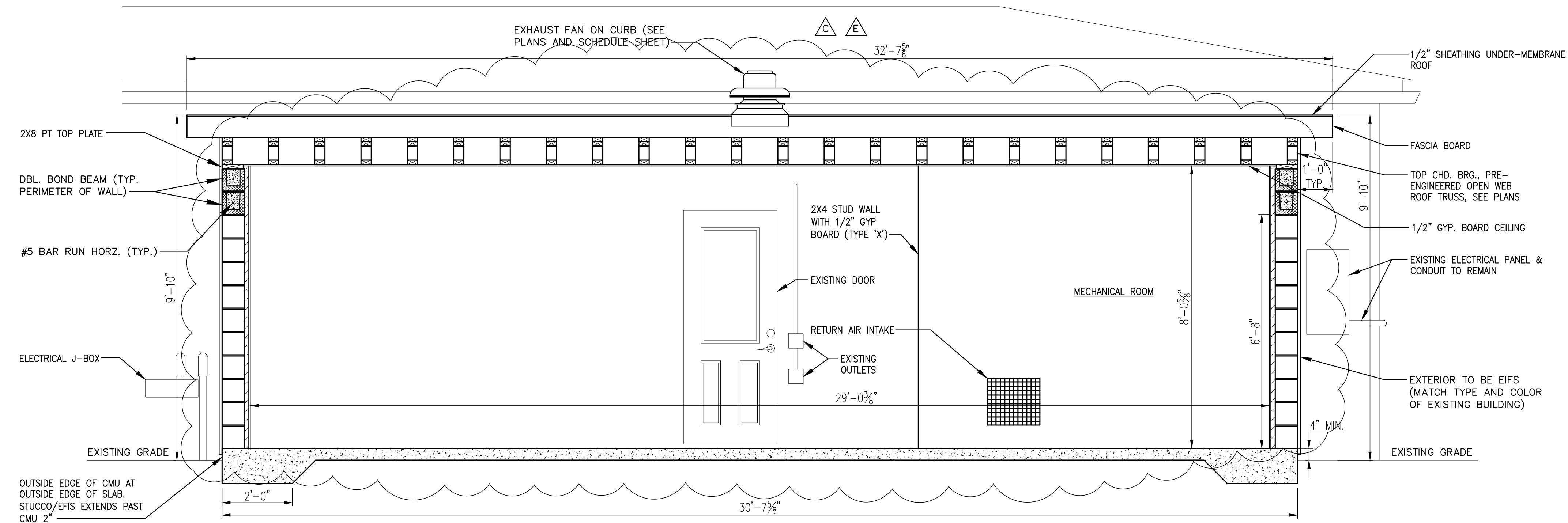

SECTION A-A

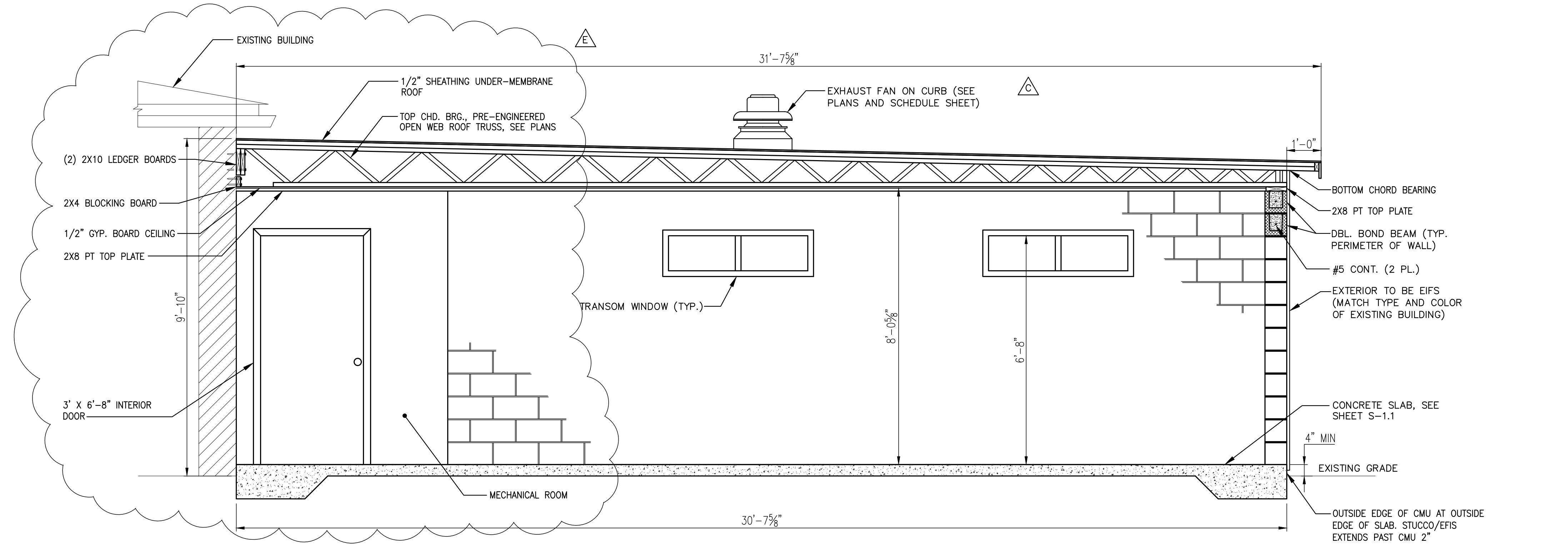
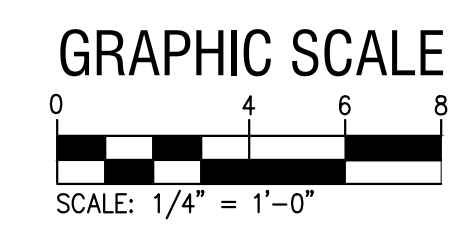

SECTION B-B

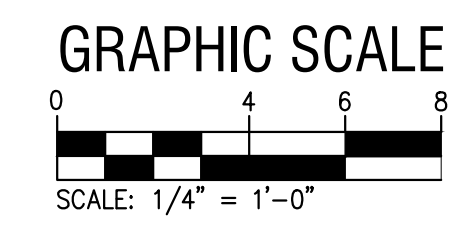

| REV | DATE | ITEM |
|-----|----------|--|
| A | 10/22/18 | OWNER REVIEW |
| B | 12/11/18 | ISSUE FOR PRICING |
| C | 04/23/19 | ADDED SPACE CONDITIONING |
| D | 06/06/19 | ADDED ERY TO MECHANICAL SYSTEM (R1) |
| E | 06/25/19 | DELETED ERY, REVISED PER OWNER COMMENTS (R2) |

GILLETTE & ASSOCIATES, INC.
CIVIL, ENVIRONMENTAL, MECHANICAL, & STRUCTURAL ENGINEERING
CERTIFICATE OF AUTHORIZATION NO. 9332
ASA R. GILLETTE, P.E. • FL. P.E. NO. 56177
20 S. 4th STREET * FERNANDINA BEACH, FL 32034
PHONE: 904-261-8819 * www.gilletteassociates.com

**NASSAU ANIMAL CONTROL
CATTERY ADDITION**
86078 LICENSE ROAD
Fernandina Beach, Florida 32034

NOTE: SOME DETAILS IN THESE DRAWINGS ARE TO BE CONSIDERED TYPICAL AND MAY NOT BE CALLED OUT ON PLANS. CONTRACTOR SHALL BECOME FAMILIAR WITH AND FOLLOW ALL DETAILS DURING CONSTRUCTION IN ALL TYPICAL AREAS.

REGISTERED DESIGN PROFESSIONAL
ASA R. GILLETTE, P.E.
FLORIDA P.E. NO. 56177

SPECIFICATIONS – HEATING, VENTILATING AND AIR CONDITIONING

1.00 – GENERAL

1.01 DESCRIPTION OF WORK

Furnish and install complete and operative HVAC system as shown on the drawing and specified herein. Work shall include, but not be limited to the following:

- A. AC units, see schedules.
- B. Exhaust fans.
- C. Thermostats, low-voltage interlock wiring and other associated devices.
- D. Ductwork and air distribution systems.
- E. Hangers and supports for ductwork, piping and HVAC equipment
- F. Flashing of duct and pipe penetrations through exterior openings.
- G. Roof curb and roof sleeper supports (if applicable).
- H. Duct Thermal and Acoustic Insulation.
- I. License, Permits and associated fees.

1.02 RELATED WORK INCLUDED UNDER OTHER SECTIONS

Plumbing, electrical, civil and architectural drawings may contain information pertinent to these drawings. Coordination between disciplines is the responsibility of the contractor.

1.03 EXAMINATION OF SITE

Visit site before performing work and check location of all conditions which will affect this work, verify dimensions and locations shown on drawings and cover all costs. Contractor shall assume reasonable variations and shall complete proposed work without additional cost. Failure to visit site prior to work will not lessen responsibility or entitle additional compensation for work not included in proposal.

1.04 DRAWINGS

The accompanying drawings shall be considered part of these specifications. Work and materials shown on the drawings and not mentioned in the specifications and vice versa shall be executed as if specifically mentioned or shown in both. The drawings shall be considered as schematic in nature and minor modifications of the work to comply with the structure as found shall be made.

1.05 RULES AND REGULATIONS

- A. All work and material shall be in full accordance with the latest rules and regulations of the State Fire Marshal and the Florida Building Code 2017 – Mechanical. Nothing in these drawings or specifications shall be construed to permit work not conforming to these codes.
- B. Contractor to notify architect or engineer of additional code requirements not listed in the drawings or specifications.

1.06 SUBMITTALS

- A. Submit for review to the tenant a complete and all-inclusive list of equipment and materials proposed for use (6 copies), accompanied by manufacturer's data sheets. The submittal shall be in a hard cover, letter-size, 3 ring binder complete with an index and index tabs. The report shall have each piece of equipment identified with a clear mark that distinguishes the product from other items on the page. Submittal shall contain ALL materials and equipment. Partial submittals will not be accepted and returned. Include six blue-line prints and one reproducible shop drawing showing proposed ductwork installation. Include sizes, locations and other required information to coordinate installation with other trades. Submittal shall be forwarded in a single package within 15 days after award of contract.
- B. Substitutions: within 5 days after award of contract, submit 6 copies of a letter stating any materials that contractor wishes to substitute, to the Owner for approval. Include such information as manufacturer's name, type of material, certified ratings, overall appearance, and necessary information to explain function and operation of material. All proposed substitutions shall be equal in quality, design, utility and appearance to material, equipment or method specified.
- C. Contractor is responsible for all required LEED documentation required for tracking and submittal to the LEED AP for commissioning and certification. Coordinate and verify all requirements prior to commencement of work.

1.07 GUARANTEE

The Contractor shall leave the entire installation in complete working order free from any defective material, workmanship or finish. He shall guarantee to repair or replace, without charge, defects due to faulty workmanship or material for a period of one year from the date of filing of the Notice of Completion.

1.08 OPERATION MANUALS AND OWNER INSTRUCTIONS

- A. Provide complete operation and maintenance manuals covering all mechanical systems and equipment that have been installed. Three (3) copies of the manual shall be bound in hardback binders.
- B. Provide instructions to space personnel as to operation of all HVAC equipment and thermostats. Instruction period to be as long as required and shall be scheduled at owner's convenience. Also, provide store manager with operation manual.
- C. Provide all operations manuals and owner instructions in electronic format in addition to the requirements above.

2.00 – PRODUCTS

2.01 DUCT (SEE GENERAL NOTES)

2.02 DUCTWORK ACCESSORIES

- A. Damper Operators
 - 1. Ducts with external insulation: Ventlock #637, DuraDyne, Young, or approved equal.
 - 2. Ducts with internal insulation and/or no insulation: Ventlock #635, DuraDyne, Young, or approved equal.
- B. Flexible Connections: Ventfabrics "Ventglas", DuraDyne, or approved equal, U.L. approved with metal attachment.
- C. Air Extractor: Titus AG-225, Krueger EX-88C, or approved equal.
- D. Turning Vanes shall comply with SMACNA HVAC Duct Construction Standards. All rectangular duct with mitered elbows shall be fitted with turning vanes.
- E. Spin-In-Fittings are not allowed. Use Crown model 616-D or similar starting collars for round duct taps.
- F. Support ductwork according to the SMACNA Duct Construction Standards and the drawings.
- G. Access Doors In Ductwork: Shall be Ventlock, Ductmate or approved equal, stamped or formed insulated access doors complete with all hardware and sealant.
- H. Joint Sealing:
 - 1. The following items are to be sealed with Hardcast DT tape and adhesive:
 - a. Longitudinal and transverse seams of rectangular ductwork.
 - b. All round fittings and joint connectors use FTA-20 for indoor use and RTA-20 for outdoor use.
 - 2. Flexible duct at diffusers shall use integral stainless steel draw band and pressure sensitive tape, Hardcast P-301 or equal.
- I. Bracings, hangers, nuts, etc. shall be galvanized.
- J. Curved elbows shall have centerline radius equal to one and one-half times duct width in plane of turn.
- K. Square elbows shall have turning vanes. Miter elbows (not square) shall have splitter vanes 3 inches o.c.
- L. Volume dampers shall be constructed to SMACNA Standards and shall be Young Regulator model 4040 for round ducts and series 820 for rectangular ducts

2.03 AIR DISTRIBUTION INSTALLATION REQUIREMENTS

- A. Duct General:

An initial site visit shall be performed and the mechanical contractor shall coordinate with the General contractor prior to duct material ordering, fabrication, and installation to insure that adequate space is made available above the ceiling both vertically out of the mechanical rooms and horizontally in the ceiling space. Change orders will not be approved for duct requirements above ceiling without this coordination.

 - 1. Duct branches shall be fitted with volume or splitter damper and where required, extraction damper. All accessible volume controls shall have locking quadrants. All inaccessible controls (dampers, etc.) shall be provided with permanent extensions to accessible spaces. Branch volume controls are in addition to volume controls at the registers and diffusers.
 - 2. Air inlets, outlets shall be properly set in place. Registers and grilles shall be tightly sealed.
 - 3. Transitions in size of ducts shall be made by uniformly tapering sections having 1 inch increase in width for each 7 inches of run unless construction limitations require a more abrupt transition.
 - 4. Diffusers, Grilles and Registers: Each register and diffuser shall be equipped with a volume damper or air extractor. Paint interior flat black. Face and trim of all units shall be finished white. Size, finish, frames, accessories, capacity and pattern as shown on drawings.
 - 5. Contractor shall provide manual volume dampers at all branch ductwork in supply air, return air and outside air systems (whether shown on plans or not) where required for air balancing of HVAC systems.

2.04 AIR DEVICES

Diffusers, Grilles and Registers: Titus brand only. Furnished and installed by Mechanical Contractor. Provide volume dampers and paint interior flat black. Size, finish, frame types and accessories as shown on the drawings. All materials to be aluminum or stainless steel. Coordinate final look w/architect.

2.05 AIR CONDITIONING EQUIPMENT

- A. Furnish and install Trane air conditioning equipment as specified on the drawings and in these specifications. Substitutions may be limited.

2.06 INSULATION (See General Notes)

- A. Heating and Cooling Ductwork located in interior locations
- B. Refrigerant Piping. See Section 2.08

2.07 TEMPERATURE CONTROL SYSTEM

- A. See Section 3.02
- B. Contractor shall post in office location, chosen by architect, concise typewritten instructions on operation of all thermostats and controls.
- C. Contractor shall provide all owner and operations manuals for all control devices (air & equipment) and literature associated with building automation and controls.

2.08 REFRIGERANT PIPING

- A. Materials: As required and supplied by manufacturer.
- B. Manufacturing: INSERT ANSI/ETC
- C. Installation: Per manufacturer requirements, drawings and specifications.
- D. Insulation: INSERT VERBAGE

3.00 – INDOOR AIR QUALITY CONTROL

3.01 OUTDOOR AIR DELIVERY MONITORING

- A. Outdoor air for all spaces receiving air conditioning and heating as listed in the equipment schedule(s) for all buildings. This shall be implemented by controlling the outside air damper at each air handling unit as listed on the drawings and schedules.
- B. Outside air dampers shall be controlled based on occupancy of space and monitoring of carbon dioxide (CO2) levels. Operations as follows:
 - 1. Occupancy Sensors: If individual room occupancy sensors detect no occupants for the ENTIRE space, as controlled by the air handling unit, the outside air damper shall be fully closed. If any individual room sensors detect occupants, the outside air damper shall reset to its default outside air rate.
 - 2. CO2 Sensors: If any of the CO2 sensors detect levels of carbon dioxide above (XXX) PPM, the outside air damper shall reset to its default outside air rate. This sensor shall override the occupancy sensor.
- C. All control information regarding occupancy, CO2 levels, signals and actuation of control devices shall be sent back to the main control or building automation system for monitoring and LEED tracking purposes.
- D. See Project Manual for LEED and overall project requirements.

3.02 CONTROLLABILITY OF SYSTEMS – THERMAL COMFORT

- A. Provide new, LEED compliant, programmable thermostat and/or humidistat for each building system, including compatibility with overall building control system and/or building automation. This shall include all necessary control devices (relays, contacts, etc.) and all direction from manufacturer on actual wiring requirements.
- B. Comfort control of conditioned and heated space to be obtained by control of sensible and latent heat gains. Sensible only control to be through use of a thermostat only controller with programming abilities to match occupancy schedules. Sensible and latent control to be through the use of a thermostat/humidistat controller to match occupancy schedules. Temperature and humidity of air conditioned and heated space shall be in accordance with the schedules.
- C. Systems that have a nominal capacity of three (3) tons or greater shall have dual compressors to allow for half-capacity operation, allowing for dehumidification. Multi-stage compressor systems shall be coupled with matching air handling units allowing for a reduction in fan speed to meet the staged amount. Half-capacity operation shall be controlled by the humidistat.
- D. Systems that have a nominal capacity of less than three (3) tons shall have a single stage compressor and will not allow for half-capacity operation. A thermostat only control device will be applicable.
- E. Areas requiring heating and ventilation only shall be controlled by thermostat only controller. This controller shall also be interlocked to the building fire alarm control panel (F.A.C.P.). See HVAC control matrix.

3.03 THERMAL COMFORT – DESIGN

- Comfort control of conditioned and heated space to be obtained by control of sensible and latent heat gains (where possible). Controls per Section 3.02.
- A. Sensible temperatures for control devices are to be set per the occupancy schedules and location temperature locations. Verify final facility operating conditions with architect.
- B. Air conditioned and heated space shown on the drawings are governed under the requirements of ASHRAE 90.1-2007 as required by the LEED documents contained in the Project Manual. Ventilation requirements for this conditioned space are governed under the requirements of ASHRAE 62.1-2007, Table 6-1 and as required by the LEED documents contained in the Project Manual.
- C. Heated and ventilated space shown on the drawings are limited to the kennel runs only with intent on canine use. These areas are not intended for human occupancy, except as required for operation, cleaning and maintenance. Heating is provided to these areas to provide reasonable, compassionate comfort to the animals. Exhaust requirements for these areas are governed under the requirements of ASHRAE 62.1-2007, Table 6-4 and as required by the LEED documents contained in the Project Manual.

3.04 THERMAL COMFORT – VERIFICATION

To determine the effectiveness and operation of thermal comfort through out the buildings, recording and analysis of building thermodynamic properties is required. Readings from control devices, sensors and interrelated parameters are to be monitored and compared to the design conditions set forth in the project documents. This control and analysis system is to be furnished by the contractor and the manufacturer representative as part of a complete operating system for the entire facility. Submit sequence for approval.

4.00 – TESTING, ADJUSTING, BALANCING

4.01 TESTING AND BALANCING

- Balancing of the air conditioning system shall be performed by NEBB certified agency.
- A. Provide sufficient time before final completion date so that test and balancing can be accomplished.
- B. Provide immediate labor and tools to make corrections when required without undue delay. Install balancing dampers as required by test and balance agency.
- C. The contractor shall put all heating, ventilating and air conditioning systems and equipment into full operation and shall continue the operation of same during each working day of testing and balancing.
- D. Testing and balancing agency shall be kept informed of any major changes made to system during construction and shall be provided with complete as-built drawings.
- E. The mechanical contractor shall include the costs of dampers, pulley and belt changes in his contract.

4.02 DESCRIPTION

Not used.

4.03 SCOPE OF WORK

- A. HVAC System Test and Balance in accordance with procedures established by NEBB
- B. Measurement of final operating conditions of HVAC equipment.
- C. Test and Balance Reports.
- D. Each piece of air conditioning and heating equipment and the air distributions systems shall be tested and adjusted to insure proper functioning of all control, proper distribution of air, maintenance of temperature, elimination of drafts, noise and vibration, and left in first class operating condition. The air system shall be readjusted if required for comfort of each room.
- E. The mechanical contractor will make any changes in the pulleys, belts, dampers, vanes, baffles and the like required for correct balance of system as recommended by T&B agency and to the satisfaction of the Owner.
- F. Provide engineering design as shown in the documents or as required to satisfy the design intent of the system. All design shall be by a State of Florida registered engineer.

4.04 SUBMITTALS

- A. Provide (6) six copies of test and balance report to the Engineer for review and approval in soft cover, letter size, 3-ring binder manual complete with index page and indexing tabs. The report shall include a set of reduced drawings with air outlets and equipment identified to correspond with data sheets and indicating thermostat locations. Electronic copies shall also be forwarded to the architect.
- B. The test and balance report shall include, as a minimum, but not be limited to:
 - 1. Each equipment shall be identified by equipment service number, manufacturer, model number, and serial number, motor horsepower, motor nameplate voltage, motor RPM, actual and design static pressure, actual outlet velocity, actual CFM, design CFM.
 - 2. Each coil shall be identified by equipment service number, manufacturer, model number and size, number of rows, total CFM, air inlet and outlet dry bulb and wet bulb temperatures.
 - 3. Each air outlet shall be identified with manufacture, model number, size, velocity, correction factor, actual CFM, design CFM.
 - 4. Traverse reading of main supply, return and outside air ducts to establish air quantities.
 - 5. Test and record temperatures from temperature controllers such as day thermostat, night thermostat.
 - 6. Test and record temperatures from main supply air trunk, mixed air during the full heating and full cooling cycle.
 - 7. Test and balance economizer (if applicable).
 - 8. Water balance information (if applicable)
 - 9. Exhaust system balance.
- C. Provide design documents as required for miscellaneous supports, routings, etc. as required to fulfill the design intent. All submitted documents shall be signed and sealed by a State of Florida registered engineer.
- D. Submit all documents required for LEED certification as shown in the Project Manual. All completed forms shall be submitted to the architect or engineer for review.

4.05 DEFICIENCIES IN SYSTEM

Balancing Contractor shall report in writing to the Owner any discrepancies on items not installed in accordance with contract documents, all deficiencies in HVAC system, and other deficiencies. The Owner will reimburse the balancing contractor if additional work is required for his phase of work.

4.06 WARRANTY

The test and balance agency shall include an extended warranty of 90 days, after completion of work, during which time the Owner, at their discretion, may request a recheck or resetting of any outlet, supply air fan, or exhaust fan as listed in test report.

4.07 DRAWING AND SPECIFICATION DISCREPANCIES

Refer to the Project Manual for additional requirements should discrepancies occur. The Project Manual will supercede with regards to procedural issues.

| REV | DATE | ITEM |
|-----|----------|-------------------------------------|
| A | 10/22/18 | OWNER REVIEW |
| B | 12/11/18 | ISSUE FOR PRICING |
| C | 04/23/19 | ADDED SPACE CONDITIONING |
| D | 06/06/19 | ADDED ERY TO MECHANICAL SYSTEM (R1) |
| E | 06/25/19 | REVISED PER OWNER COMMENTS (R2) |

| REV | DATE | ITEM |
|-----|----------|-------------------------------------|
| A | 10/22/18 | OWNER REVIEW |
| B | 12/11/18 | ISSUE FOR PRICING |
| C | 04/23/19 | ADDED SPACE CONDITIONING |
| D | 06/06/19 | ADDED ERY TO MECHANICAL SYSTEM (R1) |
| E | 06/25/19 | REVISED PER OWNER COMMENTS (R2) |

GILLETTE & ASSOCIATES, INC.
CIVIL, ENVIRONMENTAL, MECHANICAL, & STRUCTURAL ENGINEERING
CERTIFICATE OF AUTHORIZATION NO. 9332
ASA R. GILLETTE, P.E. • FL. P.E. NO. 56177
20 S. 4th STREET * FERNANDINA BEACH, FL 32034
PHONE: 904-261-8819 * www.gilletteassociates.com

**NASSAU ANIMAL CONTROL
CATTERY ADDITION**
86078 LICENSE ROAD
Fernandina Beach, Florida 32034

NOTE: SOME DETAILS IN THESE DRAWINGS ARE TO BE CONSIDERED TYPICAL AND MAY NOT BE CALLED OUT ON PLANS. CONTRACTOR SHALL BECOME FAMILIAR WITH AND FOLLOW ALL DETAILS DURING CONSTRUCTION IN ALL TYPICAL AREAS.

REGISTERED DESIGN PROFESSIONAL
ASA R. GILLETTE, P.E.
FLORIDA P.E. NO. 56177

| REV | DATE | ITEM |
|-----|----------|--|
| A | 10/22/18 | OWNER REVIEW |
| B | 12/11/18 | ISSUE FOR PRICING |
| C | 04/23/19 | ADDED SPACE CONDITIONING |
| D | 06/06/19 | ADDED ERY TO MECHANICAL SYSTEM (R1) |
| E | 06/25/19 | DELETED ERY; REVISED PER OWNER COMMENTS (R2) |

GILLETTE & ASSOCIATES, INC.
CIVIL, ENVIRONMENTAL, MECHANICAL, & STRUCTURAL ENGINEERING
CERTIFICATE OF AUTHORIZATION NO. 9332
ASA R. GILLETTE, P.E. • FL. P.E. NO. 56177
20 S. 4th STREET * FERNANDINA BEACH, FL 32034
PHONE: 904-261-8819 * www.gilletteassociates.com

**NASSAU ANIMAL CONTROL
CATTERY ADDITION**
86078 LICENSE ROAD
Fernandina Beach, Florida 32034

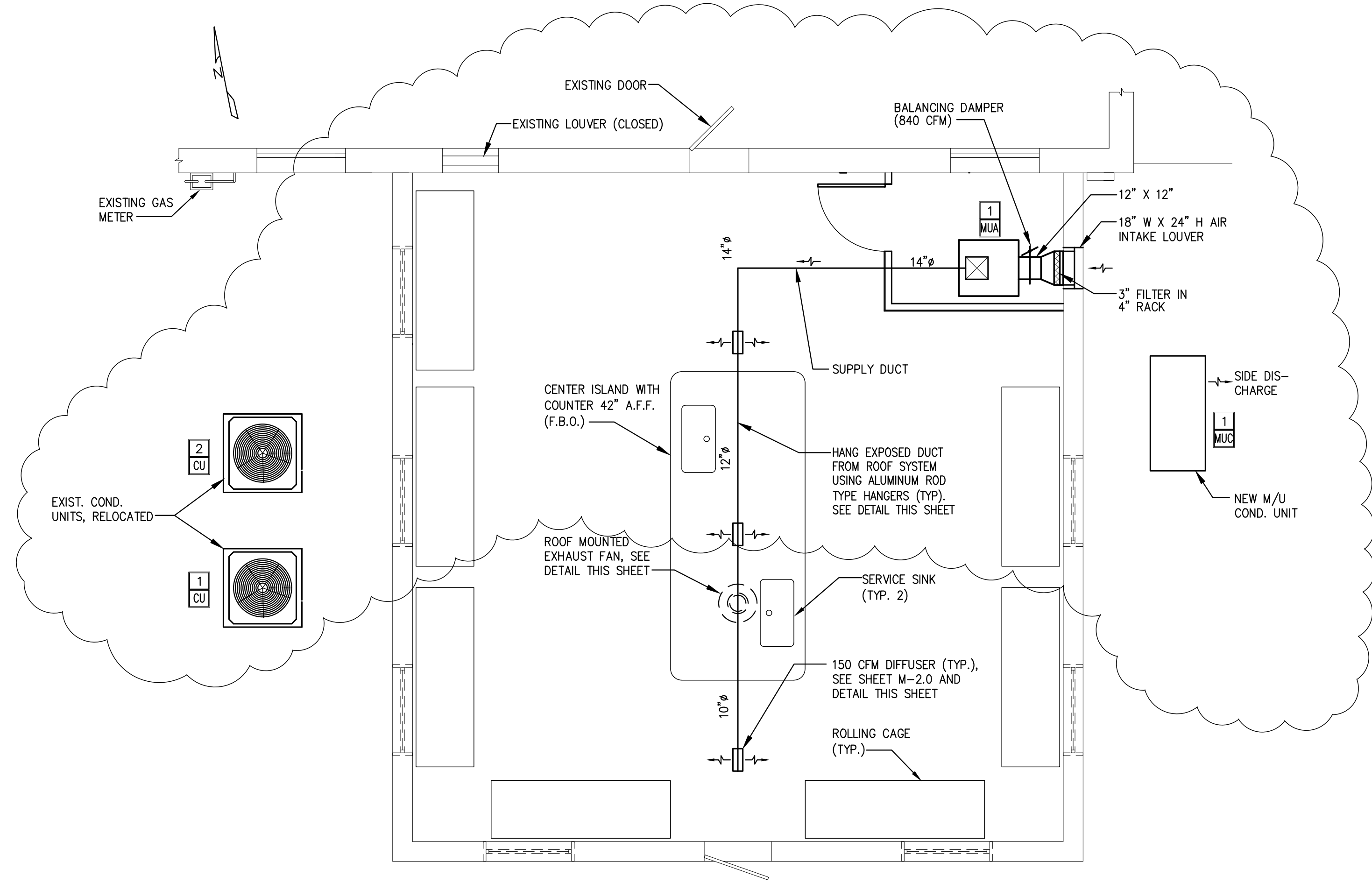

NOTE:
FINAL DUCT SIZES AND ROUTING PROVIDED BY CONTRACTOR

MECHANICAL FLOOR PLAN

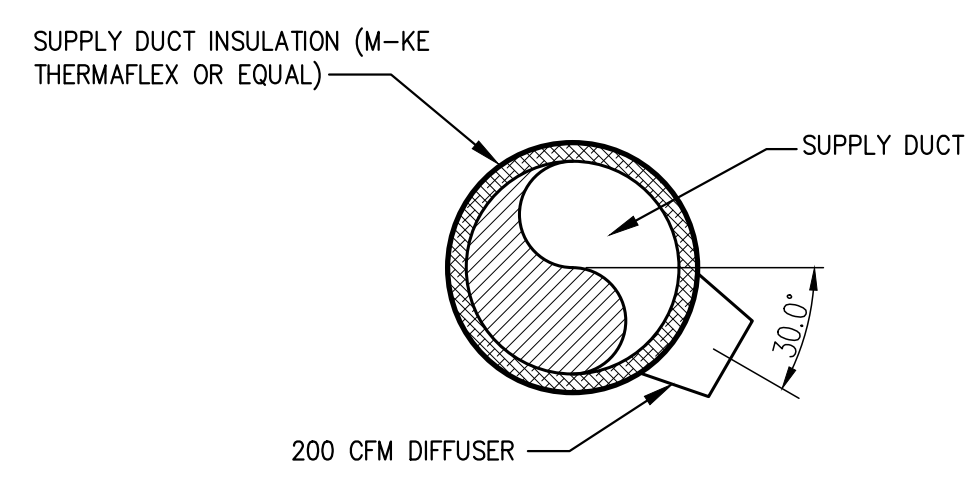
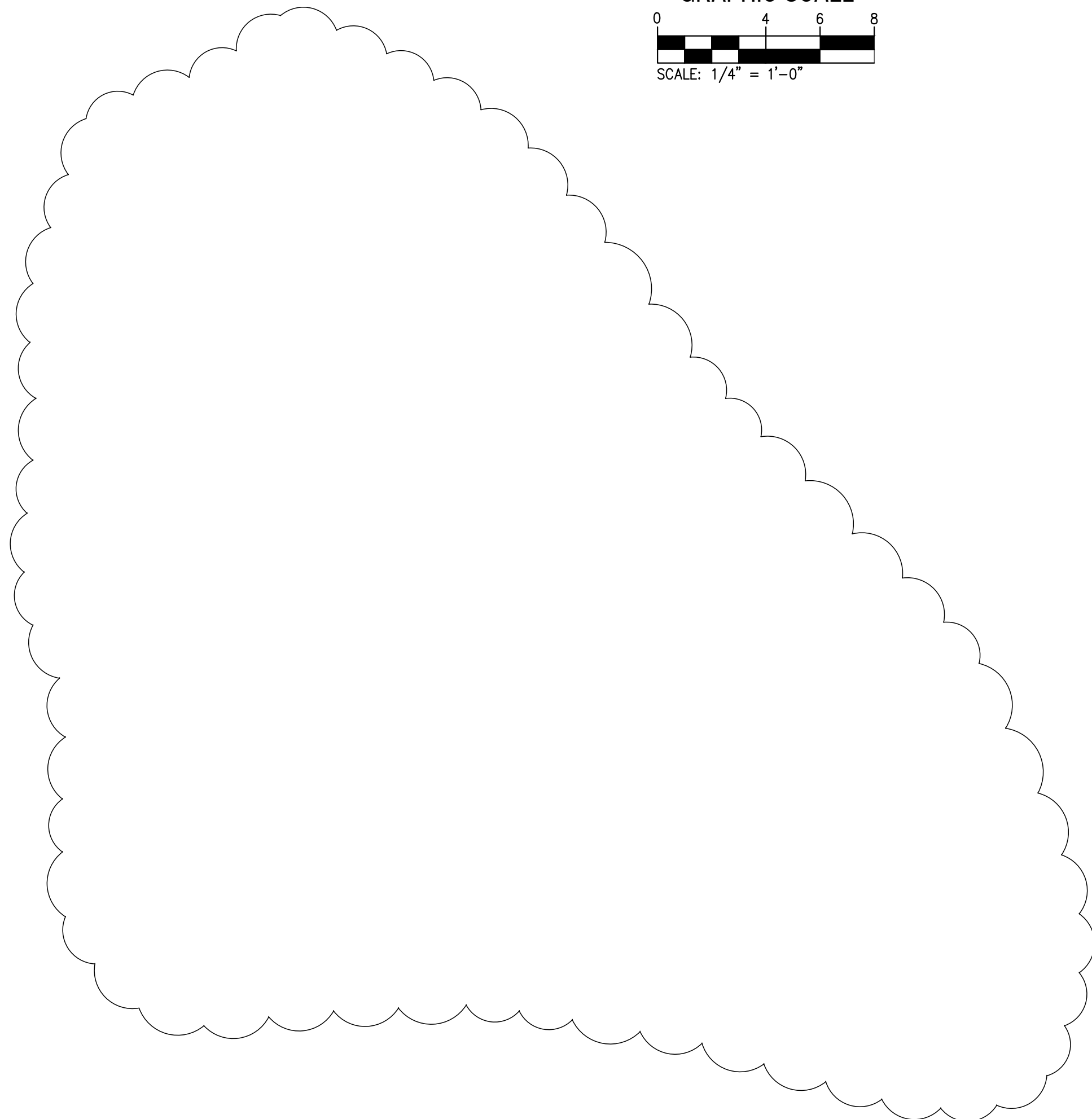
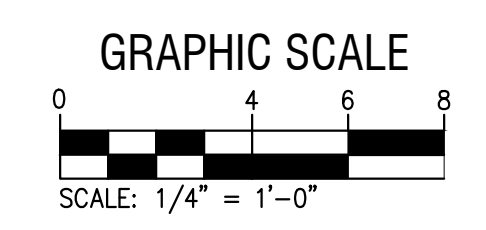

SUPPLY DIFFUSER ORIENTATION
NOT TO SCALE

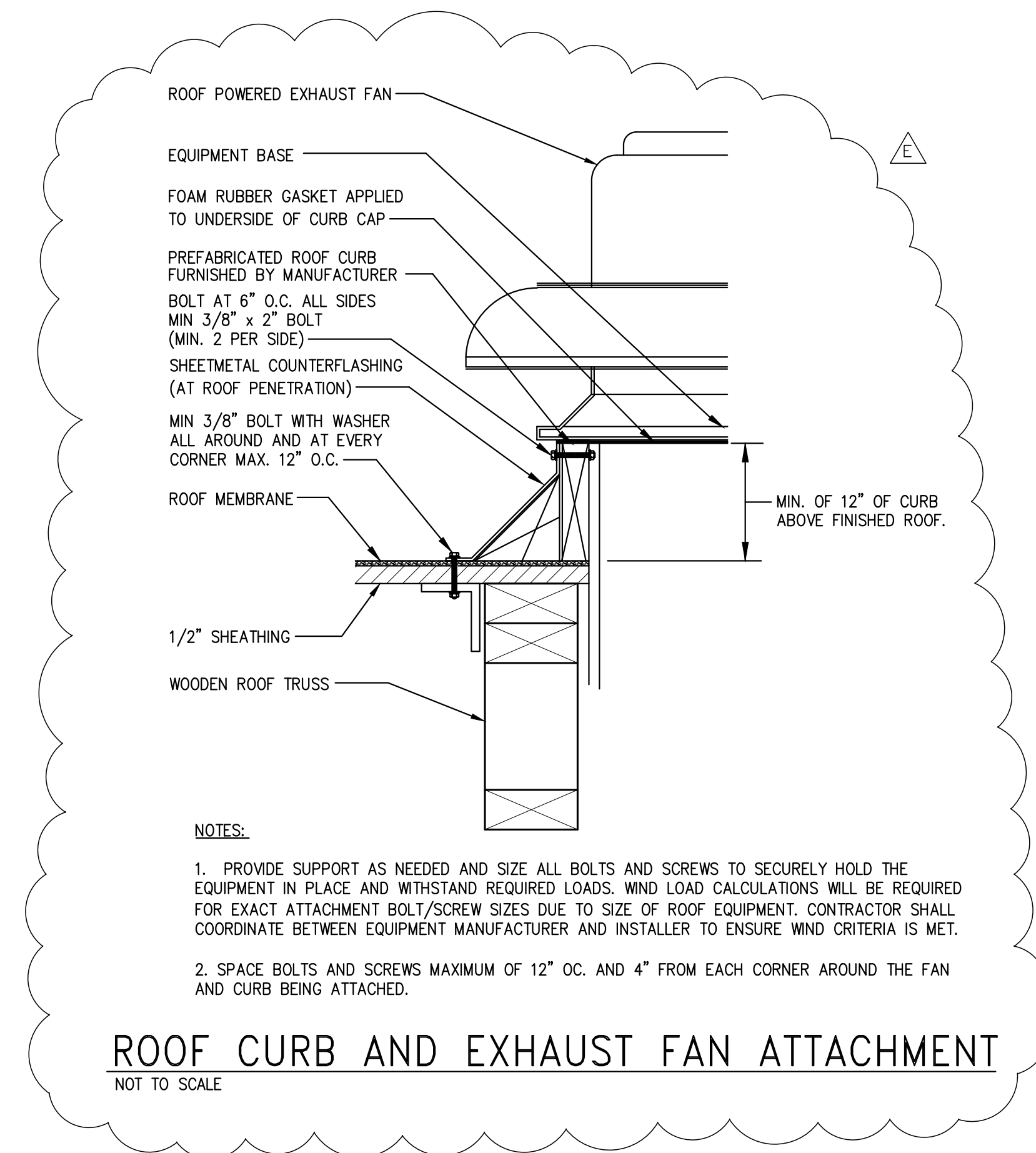

ROOF CURB AND EXHAUST FAN ATTACHMENT
NOT TO SCALE

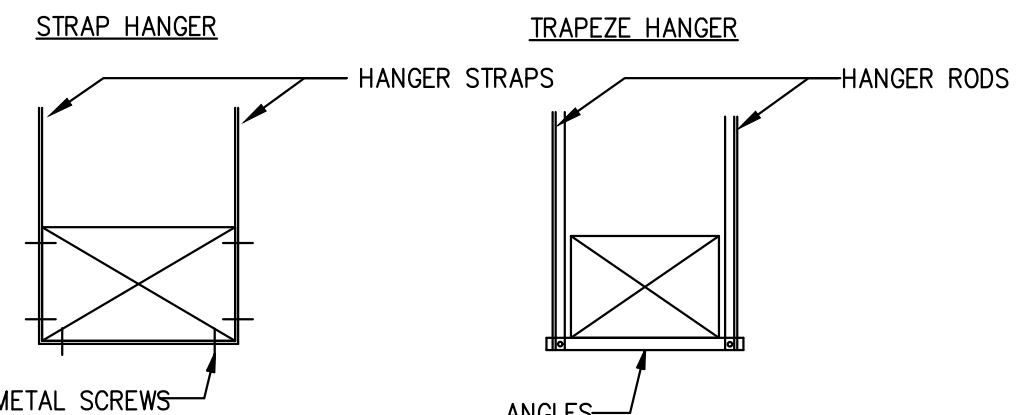

| MINIMUM RECTANGULAR DUCT HANGER SIZES | | | | | |
|---------------------------------------|-----------------|-----------|----------|-----------------|--------------|
| MAXIMUM DUCT WIDTH | MAXIMUM SPACING | WIRE SIZE | ROD SIZE | STRAP SIZE | TRAPEZE SIZE |
| 24 | 10'-0" | 10 GAUGE | --- | 1"x22 GAUGE | 1x1x16 GAUGE |
| 58 | 10'-0" | --- | 3/8" | 1"x18 GAUGE | 1x1x1/8 |
| 77 | 10'-0" | --- | 3/8" | 1"x16 GAUGE | 1.5x1.5x1/8 |
| 96 | 10'-0" | --- | 1/2" | 1-1/2"x16 GAUGE | 1.5x1.5x1/4 |
| 134 | 10'-0" | --- | 1/2" | 1-1/2"x16 GAUGE | 2.5x2.5x1/8 |
| 154 | 8'-0" | --- | 1/2" | 1-1/2"x16 GAUGE | 2.5x2.5x3/16 |
| 155 | --- | --- | --- | --- | --- |

- NOTES:
- STRAPS ARE GALVANIZED STEEL; RODS ARE COATED OR GALVANIZED STEEL; WIRE IS BLACK ANNEALED, BRIGHT BASIC OR GALVANIZED STEEL. ALL ARE ALTERNATIVES.
 - TABLE ALLOWS FOR CONVENTIONAL WALL THICKNESS, AND JOINT SYSTEMS PLUS ONE LB/SF OF INSULATION WEIGHT. IF HEAVIER DUCTS ARE TO BE INSTALLED, ADJUST HANGER SIZES TO BE WITHIN THEIR LOAD LIMITS.
 - WHEN STRAP HANGERS ARE LAP JOINED USE THE MINIMUM FASTENERS:
1"x 18, 20, 26 GAUGE 2-#10 OR 1-1/4" BOLT
1"x 16 GAUGE 2-1/4" BOLTS
1"x 14 GAUGE 2-3/8" BOLTS
 - REFER TO SMACNA HVAC CONSTRUCTION STANDARDS FOR ADDITIONAL INFORMATION.
 - AVOID UNPROTECTED CARBON STEEL OR BLACK IRON. ALL EXPOSED STEEL TO BE PROTECTED OR USE AL. OR S.S.

RECTANGULAR DUCT HANGERS
NOT TO SCALE

NOTE: SOME DETAILS IN THESE DRAWINGS ARE TO BE CONSIDERED TYPICAL AND MAY NOT BE CALLED OUT ON PLANS. CONTRACTOR SHALL BECOME FAMILIAR WITH AND FOLLOW ALL DETAILS DURING CONSTRUCTION IN ALL TYPICAL AREAS.

REGISTERED DESIGN PROFESSIONAL
ASA R. GILLETTE, P.E.
FLORIDA P.E. NO. 56177

| MAKE-UP AIR UNIT SCHEDULE | | | | | | | | | | | | | | | | | | | | | | | | | | | |
|---------------------------|-------------|----------|----------|-------------|-----------------|------|------|-----|-------------------|-----------|-----------|-----------|------------|---------------|----------|---------|--------|------------|-------------------|-----|-----|--------------|-------|----------|------|----------------|-------------------|
| UNIT I.D. | AREA SERVED | S.A. CFM | O.A. CFM | SIZE (TONS) | SUPPLY FAN DATA | | | | COOLING COIL DATA | | | | | HEAT / REHEAT | | | | COMPRESSOR | | | | MANUFACTURER | MODEL | REMARKS | | | |
| | | | | | E.S.P. | HP. | RPM | FLA | VOLTAGE (V/PH/Hz) | EAT DB/WB | LAT DB/WB | TOTAL TON | TOTAL MBH | SENS MBH | T.C. MBH | T.C. KW | STAGES | FLA | VOLTAGE (V/PH/Hz) | MCA | RLA | | | | MCA | MOCP | VOLTAGE (V/PH/Hz) |
| MUC-1 MUA-1 | ALL | 840 | 840 | 5.0 | 0.5 | 1.10 | 3450 | 3.0 | 208/1/60 | 89.0/82.0 | 75.0/XX | 5.5 (EST) | 64.4 (EST) | 33.1 (EST) | 35.8 | 10.5 | 2 | 50.5 | 208/1/60 | 67 | 26 | 35 | 60 | 208/1/60 | AAON | SEE SPEC SHEET | 1,2,3,4,5,6 |

1. HIGH EFFICIENCY UNIT
2. R-410A REFRIGERANT
3. NO HEATING SECTION
4. 100% OUTSIDE AIR
5. PROTECTIVE COATING FOR COILS
6. INTERLOCK WITH EXHAUST FAN (EF-1)

| EXHAUST FAN SCHEDULE | | | | | | | | | | | | | | |
|----------------------|---------------------|----------------|------------|-------------|------|-----|-----------------------|---------|------------|-------|------|-------------|------------|---------------|
| ID | BUILDING | AREA(S) SERVED | MANUF. | MODEL NO. | TYPE | CFM | STATIC PRESS. IN. WG. | FAN RPM | MAX. SONES | MOTOR | | VOLT/ PHASE | DRIVE TYPE | FAN INTERLOCK |
| | | | | | | | | | | RPM | BHP | | | |
| EF-1 | ANIMAL CONTROL (AC) | CATTERY | LOREN COOK | ACEB 100C3B | ROOF | 800 | 0.375 | 1818 | 11.7 | - | 0.25 | 115/1 | BELT | AHU-1 |

NOTES:
1. PROVIDE BACK-DRAFT DAMPER.
2. ROOF CURB
3. BIRD SCREEN
4. SPEED CONTROLLER
5. FRAMED TRANSITION FOR CURB

| WALL LOUVER SCHEDULE | | | | | | | | | | |
|----------------------|-------------|------|----------------|----------|-----------------|-----------------|------------------------|----------------------------------|----------------|--|
| ID | EXHAUST FAN | QTY. | BUILDING | LOCATION | FACE SIZE W X H | MOUNTING HEIGHT | LOUVER BASIS OF DESIGN | BACKDRAFT DAMPER BASIS OF DESIGN | NOTES | |
| LV-1 | EF-1 | 1 | ANIMAL CONTROL | CATTERY | 18 X 24 | 12"± | RUSKIN ELM6375DX | RUSKIN CBD6 | 1. 2. 3. 4. 5. | |

NOTES:
1. LOUVER TO BE EXTRUDED ALUMINUM, DRAINABLE WITH STATIONARY BLADES
2. MOUNTING HEIGHT IS FROM THE FINISH FLOOR TO THE BOTTOM OF THE LOUVER. VERIFY FINAL HEIGHT AND POSITION W/ARCHITECT
3. PROVIDE BIRD SCREEN
4. INSTALL EXPANSION SLEEVE AS REQUIRED IN WALLS TO ADJUST LOUVER DEPTH TO FIT. FOR KENNELS, EXTEND SLEEVE APPROX. 6" TO MOUNT BACKDRAFT DAMPER.
5. INSTALL BACKDRAFT DAMPER FLOW OF OPERATION OPPOSITE TO LOUVER AIRFLOW INTAKE SUCH THAT NEGATIVE PRESSURE RELIEF IS ACHIEVED.

| EXHAUST RATE TABLE | | | | | | |
|--------------------|--------------|----------------------|-------------------|------------------------------|--------------|-----------------|
| ID | AREA | SPACE CLASSIFICATION | FLOOR AREA (S.F.) | AVERAGE EXH. RATE (CFM/S.F.) | REQ'D OA CFM | PROVIDED OA CFM |
| EF-1 | (AC)/CATTERY | ANIMAL | 866 | 0.9 | 780 | 800 |

NOTES:
(1) EXHAUST RATES IN ACCORDANCE WITH ASHRAE 62.1, 2007, TABLE 6-4.
(2) A RECIRCULATED AIR FILTRATION SYSTEM SHALL BE UTILIZED IN ACCORDANCE WITH ASHRAE 62.1, 2007 TO PURIFY THE ROOM.

| DIFFUSER SCHEDULE | | | | | |
|--|-----------|-----|-------------|------|----------------|
| SERVICE | CFM RANGE | | MODULE SIZE | NECK | MODEL |
| | MIN | MAX | | | |
| SUPPLY - SIDEWALL (FACE MOUNT TO DUCT) (SEE NOTE 5 BELOW) | 0 | 100 | 10X3 | - | TITUS - S300FL |
| | 101 | 150 | 12X4 | - | TITUS - S300FL |
| | 151 | 200 | 12X6 | - | TITUS - S300FL |
| | 201 | 250 | 14X6 | - | TITUS - S300FL |

NOTES:
1. DIFFUSER RUNOUT SIZE SHALL BE DIFFUSER NECK SIZE, UNLESS OTHERWISE NOTED ON DRAWINGS.
2. COORDINATE COLOR OF DIFFUSERS WITH ARCHITECT.
3. TITUS S300FL GRILLES - DAMPER/EXTRACTOR REQUIRED FOR VOLUME CONTROL. UTILIZE 22.5° BLADE DEFLECTION ANGLE.

MECHANICAL NOTES:

- DUCT SIZES SHOWN ARE BASED ON NET FREE INTERNAL AREA.
- VERIFY ALL NECK SIZES ON ALL AIR TERMINALS AND EQUIPMENT. TRANSITION DUCTWORK AS NECESSARY.
- CONTRACTOR SHALL VERIFY CLEARANCE SPACE AVAILABLE. OFFSETS REQUIRED. STRUCTURAL OPENINGS AND WORK BY OTHER TRADES PRIOR TO FABRICATION OF DUCTWORK. SUBMIT SHOP DRAWINGS ON DUCTWORK LAYOUT. COORDINATE WITH ROOF STRUCTURE.
- DUCTS SHALL BE FABRICATED IN ROUND, DOUBLE WALLED, INTERNALLY INSULATED DUCT AND FITTINGS CONSISTING OF AN OUTER PRESSURE TIGHT METAL SHELL, A LAYER OF FIRE RESISTANT FIBERGLASS OR POLY INSULATION AND AN INTERNAL ACOUSTIC PLAIN METAL LINER. (DURADUCT OR EQUAL)
- DUCT SIZES AND ALL OPENINGS THRU BUILDING CONSTRUCTION SHALL SUIT EQUIPMENT FURNISHED
- LOCATE THERMOSTAT/HUMIDISTAT 54" ABOVE FINISHED FLOOR UNLESS OTHERWISE NOTED.
- ALL EQUIPMENT, DUCTWORK, ETC., SHALL BE SUPPORTED AS DETAILED AND/OR SPECIFIED. PROVIDE ADDITIONAL SUPPORTS AS REQUIRED TO PROVIDE A VIBRATION-FREE, RIGID INSTALLATION.
- ALL WORK SHALL BE COORDINATED WITH ALL TRADES INVOLVED.
- ACCESS PANELS IN DUCTWORK SHALL BE PROVIDED WHERE REQUIRED FOR OPERATION, BALANCING AND MAINTENANCE OF ALL MECHANICAL EQUIPMENT.
- ALL DUCTWORK AND PIPING IS SHOWN SCHEMATICALLY. PROVIDE ALL TRANSITIONS, FITTINGS, ETC., TO ALLOW SMOOTH FLOWS.
- VERIFY CONDITIONS IN FIELD PRIOR TO WORK AND COORDINATE WITH ALL TRADES.
- MAINTAIN CLEARANCE OF A MINIMUM OF 6" BETWEEN DUCTWORK AND EQUIPMENT, AND ALL FIRE RATED AND FIRE/SMOKE RATED PARTITIONS.
- LOCATE ALL EXHAUST FANS AND PLUMBING VENTS A MINIMUM OF 10'-0" FROM ALL OUTSIDE AIR INTAKES.

HVAC DRAIN PAN NOTES

AUXILIARY DRAIN PANS: AUXILIARY DRAIN PANS SHALL BE INSTALLED UNDER ALL COILS ON WHICH CONDENSATION WILL OCCUR AND UNDER UNITS CONTAINING COILS THAT ARE LOCATED IN SUSPENDED CEILING SPACES (I.E. BATHROOM CEILINGS). AUXILIARY DRAIN PANS SHALL HAVE A MIN. DEPTH OF 3", SHALL NOT BE LESS THAN 3" LARGER THAN THE UNIT OR COIL DIMENSIONS IN WIDTH AND LENGTH, AND SHALL BE CONSTRUCTED OF AN APPROVED CORROSION RESISTANT MATERIAL.

PROTECTION 1 OF 2 REQ'D: INSIDE THE DRAIN PAN, AN APPROVED FLOAT VALVE OR OTHER WATER LEVEL DETECTOR SHALL BE USED TO CONTROL OVERFLOW BY AUTOMATICALLY SHUTTING DOWN THE EQUIPMENT THAT PRODUCES THE CONDENSATE WHEN THE SWITCH ACTIVATES.

PROTECTION 2 OF 2 REQ'D: A SEPARATE DRAIN LINE SHALL EXTEND FROM THE TOP OF THE PAN (ABOVE THE FLOAT VALVE ACTIVATION LEVEL) TO A CONSPICUOUS POINT AND SERVE AS AN ALARM WHICH INDICATES THAT THE PRIMARY DRAIN IS RESTRICTED AND THE FLOAT VALVE IS NOT FUNCTIONING.

| REV | DATE | ITEM |
|-----|----------|--|
| A | 10/22/18 | OWNER REVIEW |
| B | 12/11/18 | ISSUE FOR PRICING |
| C | 04/23/19 | ADDED SPACE CONDITIONING |
| D | 06/06/19 | ADDED ERY TO MECHANICAL SYSTEM (R1) |
| E | 06/25/19 | DELETED ERY, REVISED PER OWNER COMMENTS (R2) |

GILLETTE & ASSOCIATES, INC.
CIVIL, ENVIRONMENTAL, MECHANICAL, & STRUCTURAL ENGINEERING
CERTIFICATE OF AUTHORIZATION NO. 0332
ASA R. GILLETTE, P.E. * FL. P.E. NO. 56177
20 S. 4th STREET * FERNANDINA BEACH, FL 32034
PHONE: 904-261-8819 * www.gilletteassociates.com

**NASSAU ANIMAL CONTROL
CATTERY ADDITION**
86078 LICENSE ROAD
Fernandina Beach, Florida 32034

NOTE: SOME DETAILS IN THESE DRAWINGS ARE TO BE CONSIDERED TYPICAL AND MAY NOT BE CALLED OUT ON PLANS. CONTRACTOR SHALL BECOME FAMILIAR WITH AND FOLLOW ALL DETAILS DURING CONSTRUCTION IN ALL TYPICAL AREAS.

REGISTERED DESIGN PROFESSIONAL
ASA R. GILLETTE, P.E.
FLORIDA P.E. NO. 56177

| REV | DATE | ITEM |
|-----|----------|--|
| A | 10/22/18 | OWNER REVIEW |
| B | 12/11/18 | ISSUE FOR PRICING |
| C | 04/23/19 | ADDED SPACE CONDITIONING |
| D | 06/06/19 | ADDED ERY TO MECHANICAL SYSTEM (R1) |
| E | 06/25/19 | DELETED ERY, REVISED PER OWNER COMMENTS (R2) |

GILLETTE & ASSOCIATES, INC.
CIVIL, ENVIRONMENTAL, MECHANICAL, & STRUCTURAL ENGINEERING
CERTIFICATE OF AUTHORIZATION NO. 9332
ASA R. GILLETTE, P.E. • FL. P.E. NO. 56177
20 S. 4th STREET * FERNANDINA BEACH, FL 32034
PHONE: 904-261-8819 * www.gilletteassociates.com

**NASSAU ANIMAL CONTROL
CATTERY ADDITION**
86078 LICENSE ROAD
Fernandina Beach, Florida 32034

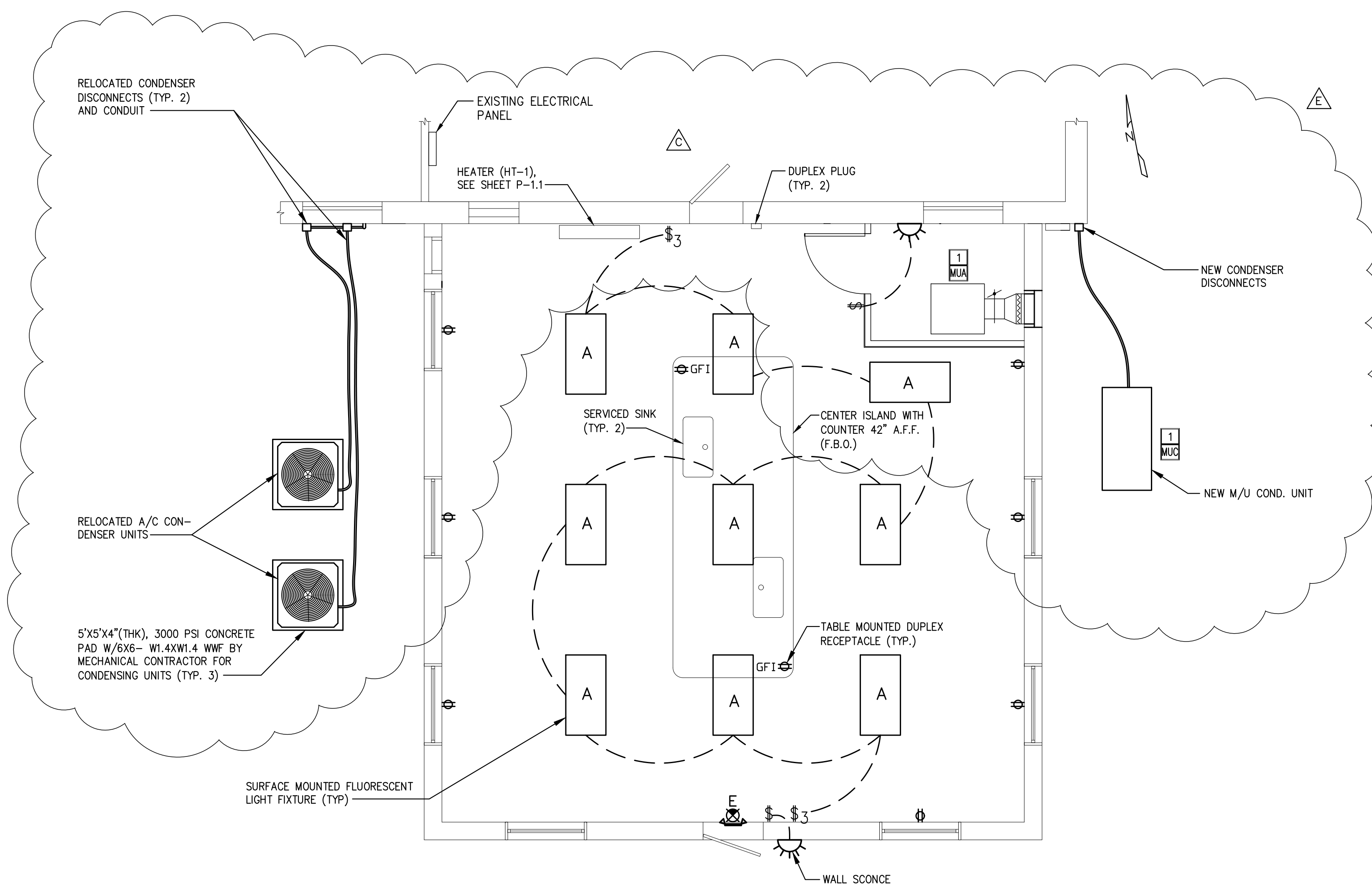

ELECTRICAL FLOOR PLAN

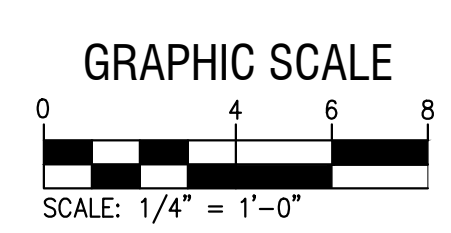

ELECTRICAL LEGEND

- DUPLEX RECEPTACLE, NEMA 5-20R, 125V, MIN. 8" A.F.F.
- GFI DUPLEX RECEPTACLE
- SINGLE POLE SWITCH, 1 WAY
- 3 WAY SWITCH
- EMERGENCY EXIT LIGHT WITH EMERGENCY LIGHT PACK
- 2'X4' SURFACE MOUNTED FLUORESCENT LIGHT
- WALL SCONCE
- ELEC. CONDUIT AND WIRING

WIRING AND CONDUIT NOTE:
ALL CONDUIT FROM PANEL TO FIXTURES TO BE MINIMUM 1/2"
ALL CONDUCTOR INSULATION SHALL BE THHN/THWN. CONDUIT SIZE IS NEC MINIMUM, CONTRACTOR AT HIS OPTION, AND AT NO ADDITIONAL COST TO OWNER, MAY INCREASE SIZE ON LONG RUNS TO AID CONDUCTOR PULLING.

- GENERAL ELECTRICAL NOTES**
- THE CONTRACTOR SHALL KEEP PRINTS OF DRAWINGS MARKED TO CLEARLY INDICATE ALL CHANGES MADE AND THE EXACT LOCATIONS OF CONDUITS CONCEALED UNDER CONCRETE OR PAVING. A COPY OF THESE DRAWINGS SHALL BE SENT TO THE OWNER UPON COMPLETION OF THE JOB.
 - THE MINIMUM SPACING BETWEEN AND THE CLEARANCE AROUND ELECTRICAL PANEL, MCC'S, CONTROLLERS, SAFETY SWITCHES, AND CONTACTORS SHALL BE AS REQUIRED BY THE NATIONAL ELECTRICAL CODE 2008, AS NOTED ON THE DRAWINGS OR AS REQUIRED BY LOCAL ORDINANCES.
 - CONDUCTORS SHALL BE AS FOLLOWS:
 - ALL CONDUCTORS SHALL BE COPPER STRANDED.
 - ALL CONDUCTORS SHALL BE TYPE "THWN" OR "THHN" UNLESS SHOWN OTHERWISE.
 - ALL EQUIPMENT EXPOSED TO THE WEATHER OR WET CONDITIONS SHALL BE NEMA 4X OR NEMA 3R WHERE INDICATED.
 - PROVIDE A NEATLY TYPED COPY OF THE APPLICABLE PANEL SCHEDULE MODIFICATIONS INSIDE EACH PANEL DOOR AND PLACE INSIDE A PLASTIC COVER. USE PANEL SCHEDULE SHEETS AS A GUIDE.
 - ALL ELECTRICAL WORK SHALL CONFORM TO LOCAL STATE AND NATIONAL ELECTRICAL CODES.
 - ALL CONDUITS, APPROVED FOR DIRECT BURIAL, SHALL BE BURIED A MINIMUM OF 36" AND SHALL BE A MINIMUM OF 1" IN DIAMETER, UNLESS OTHERWISE NOTED.
 - SPLICES:** CONDUCTORS SHALL NOT BE SPLICED EXCEPT IN OUTLETS OR JUNCTION BOXES, TROUGHS, AND GUTTERS. JUNCTION BOXES MAY BE UTILIZED WHERE REQUIRED. CONDUCTORS #10 AWG AND SMALLER SHALL BE SPLICED BY TWISTING AND INSTALLATION OF 3M "SCOTCH-LOKS" OR T&B "PIGGY" CONNECTORS. CONDUCTORS #8 AWG AND LARGER SHALL BE SPLICED WITH APPROVED MECHANICAL CONNECTORS. PLUS GUM TAPE, UNDERWRITER'S LABORATORIES LISTED, FOR USE AS SOLE INSULATION. THE GUM TAPE SHALL BE APPLIED SO AS TO COVER ALL EDGES AND FORM A SMOOTH SURFACE FOR PLASTIC TAPE. THE FINISHED CONNECTION SHALL HAVE AN INSULATION VALUE EQUAL TO THAT OF THE CONDUCTOR INSULATION.
 - ANY JUNCTION BOX TO BE SUPPORTED FROM JOIST USING BRACKETS LISTED TO MAINTAIN BOX STABILITY WITH CABLE SUSPENDED FROM IT.
 - ALL CONDUITS THAT ARE ROUTED VERTICALLY IN WALLS THAT HAVE FIRE BLOCKING AT THE TOP SHALL HAVE A SEALING SYSTEM INSTALLED AROUND THE CONDUITS WHICH PENETRATE THE FIRE BLOCKING THAT RESTORES THE INTEGRITY OF THE FIRE BLOCKING.
 - PROVIDE BONDING FOR ALL METAL RACEWAYS THAT CONTAINS GROUNDING ELECTRODE AS PER NEC 2008.
 - CONTRACTOR SHALL VISIT AND SURVEY THE SITE THOROUGHLY TO INSPECT CONDITIONS INCLUDING BUT NOT LIMITED TO ACCESS AND WORK SPACE LIMITATIONS.
 - ALL ELECTRICAL WORK TO BE IN ACCORDANCE WITH NEC 2012.
 - FINAL LIGHTING LAYOUT TO BE COORDINATED BY CONTRACTOR WITH OWNER.

NOTE: SOME DETAILS IN THESE DRAWINGS ARE TO BE CONSIDERED TYPICAL AND MAY NOT BE CALLED OUT ON PLANS. CONTRACTOR SHALL BECOME FAMILIAR WITH AND FOLLOW ALL DETAILS DURING CONSTRUCTION IN ALL TYPICAL AREAS.

REGISTERED DESIGN PROFESSIONAL
ASA R. GILLETTE, P.E.
FLORIDA P.E. NO. 56177

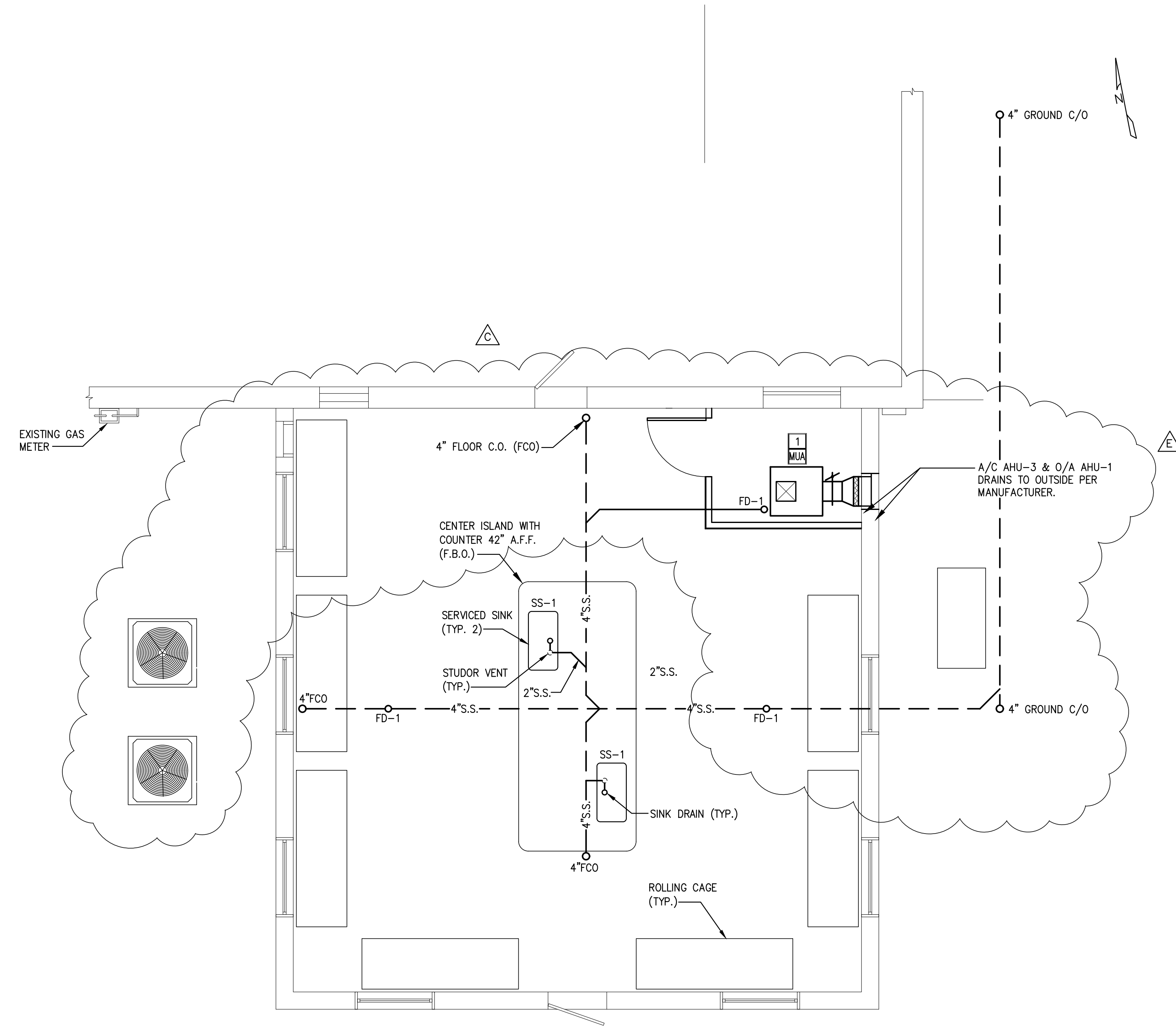

PLUMBING & GAS FLOOR PLAN

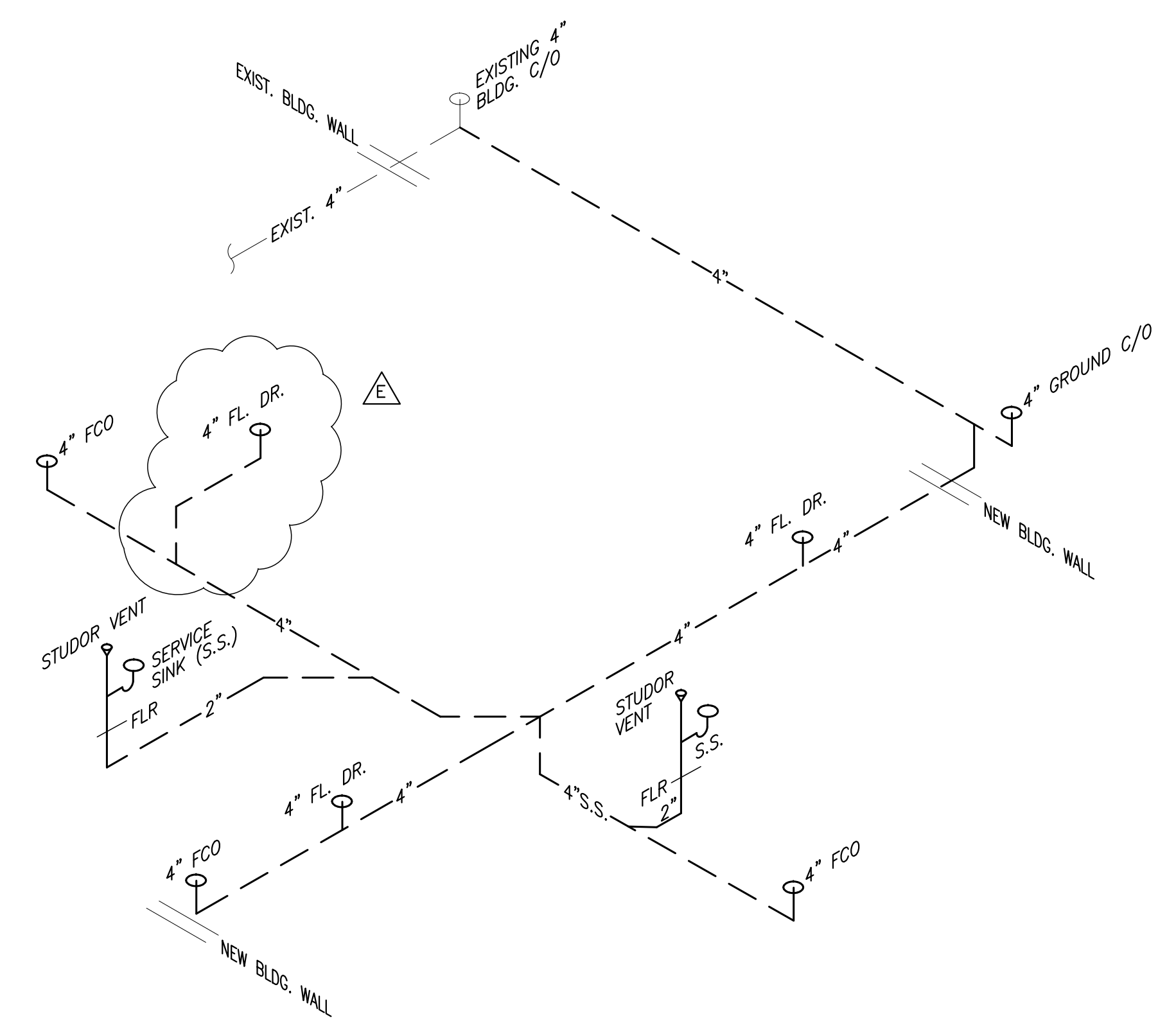
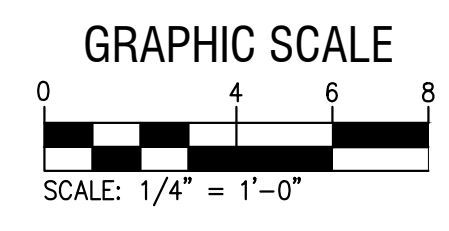

SANITARY SEWER ISOMETRIC
NOT TO SCALE

| REV | DATE | ITEM |
|-----|----------|--|
| A | 10/22/18 | OWNER REVIEW |
| B | 12/11/18 | ISSUE FOR PRICING |
| C | 04/23/19 | ADDED SPACE CONDITIONING |
| D | 06/06/19 | ADDED ERY TO MECHANICAL SYSTEM (R1) |
| E | 06/25/19 | DELETED ERY, REVISED PER OWNER COMMENTS (R2) |

GILLETTE & ASSOCIATES, INC.
CIVIL, ENVIRONMENTAL, MECHANICAL, & STRUCTURAL ENGINEERING
CERTIFICATE OF AUTHORIZATION NO. 9332
ASA R. GILLETTE, P.E. • FL. P.E. NO. 56177
20 S. 4th STREET * FERNANDINA BEACH, FL 32034
PHONE: 904-261-8819 * www.gilletteassociates.com

**NASSAU ANIMAL CONTROL
CATTERY ADDITION**
86078 LICENSE ROAD
Fernandina Beach, Florida 32034

APPENDIX C

CAGE SPECIFICATIONS

Manufacturer: SHOR-LINE (SCHROER MANUFACTURING COMPANY)

Product/Item Number: 902.0110.26

Product Description: 9' Assembly, Stainless Steel Cages, OPTION C, with Mobile Platform. Includes: (Top) Two (2) 30"x 24" Cages, Two (2) 24"x 24" Cages, (Middle) Two (2) 30"x 24" Cages, Two (2) 24"x 24" Cages, (Bottom) Three (3) 36"x 30" Cages

Quantity: 10 Each

These Cages are the ONLY cages that can be used for the Animal Services Cattery Addition.

EXHIBIT 1

GENERAL INFORMATION AND MINIMUM INSURANCE REQUIREMENTS

GENERAL INFORMATION AND MINIMUM INSURANCE REQUIREMENTS

COMMERCIAL GENERAL LIABILITY INSURANCE

The Contractor shall purchase and maintain at the Contractor’s expense Commercial General Liability insurance coverage (ISO or comparable Occurrence Form) for the life of this Contract. Modified Occurrence or Claims Made forms are not acceptable.

The Limits of this insurance shall not be less than the following limits:

| | |
|--|-------------|
| Each Occurrence Limit | \$1,000,000 |
| Personal & Advertising Injury Limit | \$1,000,000 |
| Fire Damage Limit (any one fire) | \$ 50,000 |
| Medical Expense Limit (any one person) | \$ 5,000 |
| Products & Completed Operations Aggregate Limit | \$2,000,000 |
| General Aggregate Limit (other than Products & Completed Operations) Applies Per Project | \$2,000,000 |

General liability coverage shall continue to apply to “bodily injury” and to “property damage” occurring after all work on the Site of the covered operations to be performed by or on behalf of the additional insureds has been completed and shall continue after that portion of “your work” out of which the injury or damage arises has been put to its intended use.

WORKERS’ COMPENSATION AND EMPLOYER’S LIABILITY INSURANCE

The Contractor shall purchase and maintain at the Contractor’s expense Workers’ Compensation and Employer’s Liability insurance coverage for the life of this Contract.

The Limits of this insurance shall not be less than the following limits:

| | |
|--|-------------------------|
| <u>Part One</u> – Workers’ Compensation Insurance – Unlimited Statutory Benefits as provided in the Florida Statutes and | |
| <u>Part Two</u> – Employer’s Liability Insurance | |
| Bodily Injury By Accident | \$500,000 Each Accident |
| Bodily Injury By Disease | \$500,000 Policy Limit |
| Bodily Injury By Disease | \$500,000 Each Employee |

*If leased employees are used, policy must include an Alternate Employer’s Endorsement

AUTOMOBILE LIABILITY INSURANCE

The Contractor shall purchase and maintain at the Contractor’s expense Automobile Liability insurance coverage for the life of this Contract.

The Limits of this insurance shall not be less than the following limits:

| | |
|---------------------------------------|-------------|
| Combined Single Limit – Each Accident | \$1,000,000 |
|---------------------------------------|-------------|

Covered Automobiles shall include any auto owned or operated by the insured Contractor, insured Sub-subcontractor including autos which are leased, hired, rented or borrowed, including autos owned by their employees which are used in connection with the business of the respective Contractor or Sub-subcontractor.

UMBRELLA INSURANCE

The Contractor shall purchase and maintain at the Contractor's expense Umbrella Liability (Umbrella Form) insurance coverage for the life of this Contract.

The Limits of this insurance shall not be less than the following limits:

| | |
|-----------------------|-------------|
| Each Occurrence Limit | \$1,000,000 |
| Aggregate Limit | \$1,000,000 |

ENVIRONMENTAL LIABILITY INSURANCE

This additional coverage will be required by any Contractor performing environmental and/or other investigations involving excavation, drilling, or other site disturbance activities.

The Contractor shall purchase and maintain at the Contractor's expense Environmental Liability insurance (Contractors Pollution Liability) coverage for the life of this Contract.

The Limits of insurance shall not be less than the following limits: \$1,000,000 Each
Loss/Aggregate

Such Coverage will include bodily injury, sickness, and disease, mental anguish or shock sustained by any person, including death; property damage including physical injury to destruction of tangible property including resulting loss of use thereof, cleanup costs, and the loss of use of tangible property that has not been physically injured or destroyed; defense including costs charges and expenses incurred in the investigation, adjustment or defense of claims for such compensatory damages; coverage for losses caused by pollution conditions that arises from the operations of the contractor including transportation.

BUILDERS RISK OR INSTALLATION FLOATER

This additional coverage will be required if the contract includes construction of or additions to above-ground buildings or structures, or installation of machinery or equipment.

The minimum amount of insurance shall be 100% of the completed value of such addition(s), building(s), or structure(s), or the installed replacement cost of value.



Contractor shall require each of his Subcontractors to likewise purchase and maintain at their expense Commercial General Liability insurance, Workers' Compensation and Employer's Liability coverage, Automobile Liability insurance, Umbrella Liability Professional Liability, Environmental Liability, Builders Risk or Installation Floater (as applicable) insurance coverage meeting the same limit and requirements as the Contractors insurance.

Certificates of Insurance acceptable to Nassau County Board of County Commissioners for the Contractor's insurance must be received within five (5) days of Notification of Selection and at time of signing Agreement.

Certificates of Insurance and the insurance policies required for this Agreement shall contain an endorsement that coverage afforded under the policies will not be cancelled or allowed to expire until at

least thirty (30) days prior written notice has been given to Nassau County Board of County Commissioners.

Certificates of Insurance and the insurance policies required for this Agreement will include a provision that policies, except Workers' Compensation and Professional Liability, are primary and noncontributory to any insurance maintained by the Contractor.

Nassau County Board of County Commissioners must be named as an Additional Insured and endorsed onto the Commercial General Liability (CGL), Auto Liability and Umbrella Liability policy (ies). A copy of the endorsement(s) must be supplied to Nassau County Board of County Commissioners ten (10) days following the execution of the agreement or prior to the first date of services, whichever comes first.

CGL policy Additional Insured Endorsement must include Ongoing and Completed Operations (Form CG2010 11 84 **OR** Form CG2010 04 13 and GC2037 04 13 edition or equivalent). Other Additional Insured forms might be acceptable but only if modified to delete the word "ongoing" and insert the sentence "Operations include ongoing and completed operations".
CGL policy shall not be endorsed with Exclusion - Damage to Work performed by Subcontractors on Your Behalf (CG2294 or CG2295)
CGL policy shall not be endorsed with Contractual Liability Limitation Endorsement (CG2139) or Amendment of Insured Contract Definition (CG 2426)
CGL policy shall not be endorsed with Exclusion - Damage to Premises Rented to you (CG 2145)
CGL policy shall include broad form contractual liability coverage for the Contractors covenants to and indemnification of the Authority under this Contract

Certificates of Insurance and the insurance policies required for this Agreement shall contain a provision under General Liability, Auto Liability and Workers' Compensation to include a Waiver of Subrogation clause in favor of Nassau County Board of County Commissioners.

All Certificates of Insurance shall be dated and shall show the name of the insured Contractor, the specific job by name and job number, the name of the insurer, the policy number assigned its effective date and its termination date and a list of any exclusionary endorsements.

All Insurers must be authorized to transact insurance business in the State of Florida as provided by Florida Statute 624.09(1) and the most recent Rating Classification/Financial Category of the insurer as published in the latest edition of "Best's Key Rating Guide" (Property-Casualty) must be at least A- or above.

All of the above referenced Insurance coverage is required to remain in force for the duration of this Agreement and for the duration of the warranty period. Accordingly, at the time of submission of final application for payment, Contractor shall submit an additional Certificate of Insurance evidencing continuation of such coverage.

If the Contractor fails to procure, maintain or pay for the required insurance, Nassau County Board of County Commissioners shall have the right (but not the obligation) to secure same in the name of and for the account of Contractor, in which event, Contractor shall pay the cost thereof and shall furnish upon demand, all information that may be required to procure such insurance. Nassau County Board of County Commissioners shall have the right to back-charge contractor for the cost of procuring such insurance. The failure of Nassau County Board of County Commissioners to demand certificates of insurance and endorsements evidencing the required insurance or to identify any deficiency in contractors coverage based on the evidence of insurance provided by the contractor shall not be construed as a waiver by Nassau County Board of County Commissioners of contractor's obligation to procure, maintain and pay for required insurance.

The insurance requirements set forth herein shall in no way limit Contractors liability arising out of the work performed under the Agreement or related activities. The inclusions, coverage and limits set forth

herein are minimum inclusion, coverage and limits. The required minimum policy limits set forth shall not be construed as a limitation of Contractor's right under any policy with higher limits, and no policy maintained by the Contractor shall be construed as limiting the type, quality or quantity of insurance coverage that Contractor should maintain. Contractor shall be responsible for determining appropriate inclusions, coverage and limits, which may be in excess of the minimum requirements set forth herein.

If the insurance of any Contractor or any subcontractor contains deductible(s), penalty(ies) or self-insured retention(s), the Contractor or Subcontractor whose insurance contains such provision(s) shall be solely responsible for payment of such deductible(s), penalty(ies) or self-insured retention(s).

The failure of Contractor to fully and strictly comply at all times with the insurance requirements set forth herein shall be deemed a material breach of the Agreement.